

Application Note: Radical Cyclization Cascades Using 4-Ethylbenzenesulfonohydrazide

Author: BenchChem Technical Support Team. **Date:** May 2026

Compound of Interest

Compound Name: 4-Ethylbenzenesulfonohydrazide

CAS No.: 18684-10-1

Cat. No.: B2405489

[Get Quote](#)

Executive Summary

This technical guide details the application of **4-Ethylbenzenesulfonohydrazide** (CAS: 19064-69-8) as a robust precursor for sulfonyl radicals in drug discovery. Unlike sulfonyl chlorides, which are moisture-sensitive and corrosive, sulfonyl hydrazides are shelf-stable solids that release radicals under mild oxidative or electrochemical conditions.

The focus of this note is the radical cascade cyclization, a powerful transformation that constructs sulfonated heterocyclic cores (e.g., oxindoles, phenanthridines) in a single step. We specifically address the utility of the 4-ethyl congener, which offers a unique lipophilic profile (

adjustment) compared to the standard tosyl (4-methyl) derivatives, crucial for Structure-Activity Relationship (SAR) tuning in late-stage lead optimization.

Mechanistic Insight & Chemical Logic

The utility of **4-Ethylbenzenesulfonohydrazide** relies on its ability to undergo oxidative decomposition to generate the 4-ethylbenzenesulfonyl radical. This species is distinct because it resists desulfitative decomposition (loss of

) under moderate conditions, allowing for the installation of the intact sulfone moiety—a key pharmacophore.

The Radical Generation Cycle (Iodide-Mediated)

The most reliable method for generating these radicals avoids toxic metal oxidants, utilizing instead a TBAI (Tetrabutylammonium iodide) / TBHP (tert-Butyl hydroperoxide) catalytic system.

- Initiation: TBHP oxidizes iodide () to hypoiodite or iodine radical species.
- Activation: The iodine species oxidizes the hydrazide, leading to the extrusion of molecular nitrogen () and protons.
- Radical Release: The 4-ethylbenzenesulfonyl radical () is liberated.
- SOMO Attack: The electrophilic radical attacks the alkene/alkyne -system (Single Occupied Molecular Orbital interaction).
- Cyclization: The resulting carbon-centered radical cyclizes onto a pendant aromatic ring (homolytic aromatic substitution).

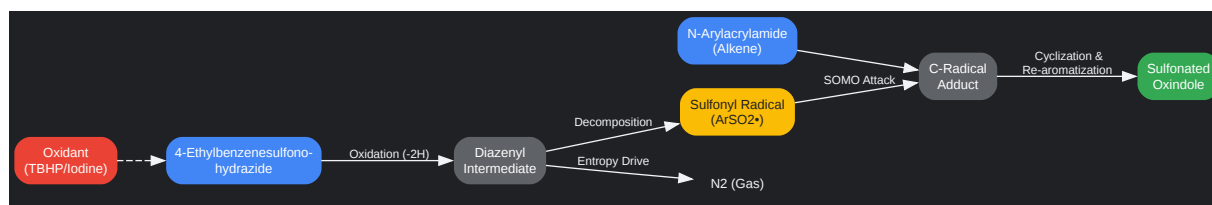

[Click to download full resolution via product page](#)

Figure 1: Mechanistic pathway for the oxidative generation of sulfonyl radicals and subsequent cascade cyclization.[1]

Application Protocols

Protocol A: Chemical Oxidative Cyclization (Oxindole Synthesis)

Target: Synthesis of 3-(4-ethylbenzenesulfonyl)oxindoles from N-arylacrylamides. Mechanism: TBAI-catalyzed radical cascade.

Materials

- Substrate: N-methyl-N-phenylmethacrylamide (1.0 equiv).
- Reagent: **4-Ethylbenzenesulfonohydrazide** (2.0 equiv).
- Catalyst: TBAI (Tetrabutylammonium iodide) (20 mol%).
- Oxidant: TBHP (70% in water) (3.0 equiv).
- Solvent: DCE (1,2-Dichloroethane) or Ethyl Acetate (Green alternative).

Step-by-Step Methodology

- Charge: To a dried reaction tube equipped with a magnetic stir bar, add the N-arylacrylamide substrate (0.5 mmol) and **4-Ethylbenzenesulfonohydrazide** (1.0 mmol, 200 mg).
- Catalyst Addition: Add TBAI (0.1 mmol, 37 mg).
- Solvation: Add DCE (3.0 mL). Note: Ensure the hydrazide is well-suspended.
- Oxidant Injection: Dropwise add TBHP (1.5 mmol) at room temperature.
 - Self-Validating Sign: The solution should darken (iodine generation) and slight bubbling (release) may be observed.
- Reaction: Seal the tube and heat to 80°C for 6–12 hours.

- Monitoring: Monitor by TLC. The hydrazide spot (polar) will disappear. The product is usually less polar than the starting acrylamide.
- Workup: Cool to RT. Quench with saturated (sodium thiosulfate) to remove iodine (color changes from dark brown to pale yellow). Extract with DCM (mL).
- Purification: Silica gel column chromatography (Hexane/EtOAc gradient).

Why this works: The excess hydrazide compensates for non-productive decomposition. The temperature (80°C) is optimized to ensure the rate of radical addition competes favorably with radical quenching.

Protocol B: Electrochemical Radical Sulfonylation (Green Chemistry)

Target: Catalyst-free generation of sulfonyl radicals for vinyl sulfone synthesis or cyclization.

Advantage: Eliminates the need for potentially hazardous peroxides (TBHP).

Setup Specifications

- Cell: Undivided glass cell (15 mL).
- Anode: Reticulated Vitreous Carbon (RVC) or Graphite.
- Cathode: Platinum plate or Nickel foam.
- Power Source: DC Power Supply (Constant Current).

Step-by-Step Methodology

- Electrolyte Prep: Dissolve (0.1 M) or in a solvent mixture of

(1:1 v/v).

- Note: Water is essential here as a proton source/sink and to facilitate hydrazide solubility.
- Loading: Add alkene substrate (0.3 mmol) and **4-Ethylbenzenesulfonohydrazide** (0.6 mmol).
- Electrolysis: Insert electrodes (submerged ~1.5 cm). Set constant current (CCE) to 10 mA.
- Duration: Stir at room temperature for 3–4 hours.
 - Calculation: Theoretical charge is 2 F/mol. Run to ~2.5 F/mol to ensure completion.
- Validation: Monitor voltage. A sharp rise in voltage often indicates depletion of the active hydrazide species.
- Workup: Disconnect power. Extract aqueous layer with EtOAc.

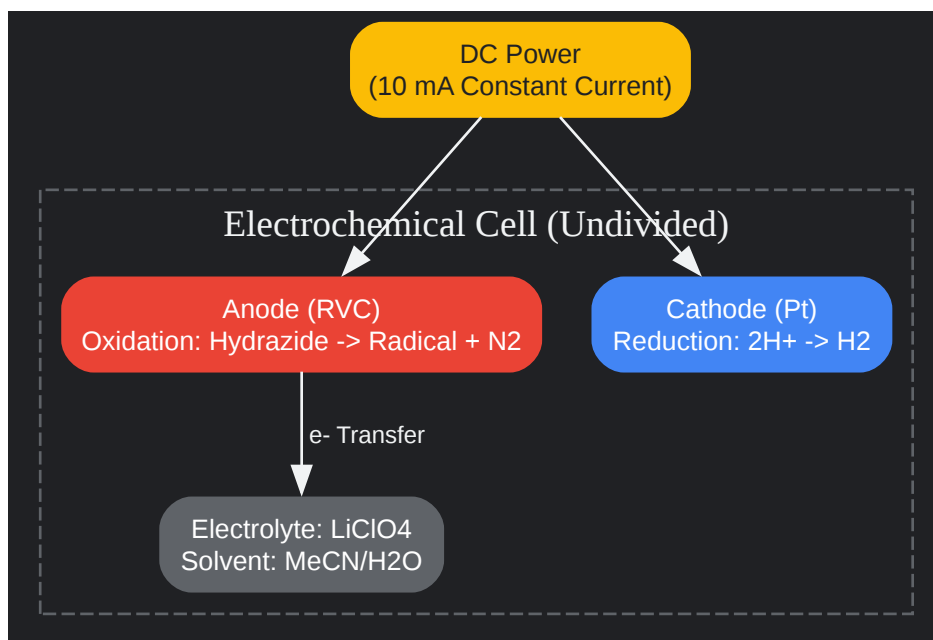

[Click to download full resolution via product page](#)

Figure 2: Electrochemical setup for oxidant-free radical generation.

Data Summary & Troubleshooting

Comparative Yields (Representative Substrates)

| Substrate Type | Method A (Chemical) Yield | Method B (Electro) Yield | Notes |
|---------------------------------|------------------------------|-----------------------------|---|
| N-Methyl-N-phenylmethacrylamide | 82% | 75% | Chemical method faster; Electro method cleaner profile. |
| Styrene (Vinyl Sulfone Product) | 65% | 88% | Electro method superior for simple intermolecular addition. |
| N-Benzyl-N-methacryloyl amide | 78% | 70% | 4-Ethyl group tolerates steric bulk well. |

Troubleshooting Guide (Self-Validating)

- Issue: Low conversion, hydrazide remains.
 - Diagnosis: Radical initiation failure.
 - Fix (Chemical): Add another 10 mol% TBAI. Ensure temperature is $>75^{\circ}\text{C}$.
 - Fix (Electro): Clean the anode surface (passivation can occur). Increase solvent conductivity.
- Issue: Formation of Desulfitative product (Ar-H or Ar-Alkene without).
 - Cause: Temperature too high or solvent promotes extrusion.
 - Fix: Lower temperature to 60°C . Avoid pure aqueous systems for the chemical method; use DCE/DCM.

- Issue: "4-Ethyl" specific solubility issues.
 - Insight: The ethyl group makes the reagent less soluble in water than the methyl (tosyl) analog.
 - Fix: In aqueous protocols, use a co-solvent (MeCN or THF) to ensure homogeneity.

References

- Wei, W., et al. (2013). "TBAI-Catalyzed Oxidative Synthesis of Sulfonated Oxindoles from N-Arylacrylamides and Sulfonylhydrazides." *Organic Letters*. [[Link](#)][2]
- Lai, Y. L., et al. (2020). "Electrochemical sulfonylation of alkenes with sulfonyl hydrazides: a metal- and oxidant-free protocol for the synthesis of (E)-vinyl sulfones in water." *RSC Advances*. [[Link](#)]
- Tang, S., et al. (2018). "Sulfonyl Hydrazides as Sulfonyl Radical Precursors in Organic Synthesis." *Advanced Synthesis & Catalysis*. [[Link](#)]
- Chen, Z., et al. (2016).[2] "I2-Catalyzed Oxidative Coupling Reactions... in the Synthesis of 1,3,5-Trisubstituted 1,2,4-Triazoles." *Organic Letters*. [[Link](#)][2]

Need Custom Synthesis?

BenchChem offers custom synthesis for rare earth carbides and specific isotopic labeling.

Email: info@benchchem.com or [Request Quote Online](#).

Sources

- [1. Radical cyclizations of cyclic ene sulfonamides occur with \$\beta\$ -elimination of sulfonyl radicals to form polycyclic imines - PMC \[pmc.ncbi.nlm.nih.gov\]](#)
- [2. I2-Catalyzed Oxidative Coupling Reactions of Hydrazones and Amines and the Application in the Synthesis of 1,3,5-Trisubstituted 1,2,4-Triazoles \[organic-chemistry.org\]](#)
- To cite this document: BenchChem. [Application Note: Radical Cyclization Cascades Using 4-Ethylbenzenesulfonohydrazide]. BenchChem, [2026]. [Online PDF]. Available at:

[\[https://www.benchchem.com/product/b2405489/docs#application-note-radical-cyclization-cascades-using-4-ethylbenzenesulfonohydrazide\]](https://www.benchchem.com/product/b2405489/docs#application-note-radical-cyclization-cascades-using-4-ethylbenzenesulfonohydrazide)

Disclaimer & Data Validity:

The information provided in this document is for Research Use Only (RUO) and is strictly not intended for diagnostic or therapeutic procedures. While BenchChem strives to provide accurate protocols, we make no warranties, express or implied, regarding the fitness of this product for every specific experimental setup.

Technical Support: The protocols provided are for reference purposes. Unsure if this reagent suits your experiment?

Need Industrial/Bulk Grade? [Request Custom Synthesis Quote](#)

BenchChem

Our mission is to be the trusted global source of essential and advanced chemicals, empowering scientists and researchers to drive progress in science and industry.

Contact

Address: 3281 E Guasti Rd
Ontario, CA 91761, United States
Phone: (601) 213-4426
Email: info@benchchem.com

[Contact our Ph.D. Support Team for a compatibility check](#)