

Comparative Mass Spectrometry Guide: Fragmentation Dynamics of Brominated Aryl Hydrazines

Author: BenchChem Technical Support Team. **Date:** April 2026

Compound of Interest

Compound Name:	<i>(4-Bromobenzyl)hydrazine dihydrochloride</i>
CAS No.:	1260812-19-8
Cat. No.:	B2404801

[Get Quote](#)

Executive Summary

Hydrazines are critical pharmacophores and synthetic intermediates, yet their structural instability and potential genotoxicity pose significant analytical challenges.[3][4] In drug development, distinguishing brominated hydrazine analogs is vital for metabolic profiling and impurity quantification.

This guide provides a technical comparison of the mass spectrometric (MS) behavior of Brominated Aryl Hydrazines versus their non-halogenated and chlorinated counterparts. It focuses on the unique fragmentation pathways induced by the bromine substituent—specifically the interplay between the labile N–N bond and the C–Br bond—and enables researchers to validate structural assignments with high confidence.

Fundamentals of Detection The Bromine Isotopic Signature

The most immediate diagnostic feature of brominated hydrazines is the isotopic abundance of Bromine (

and

). Unlike chlorine (3:1 ratio) or fluorine (monoisotopic), bromine exhibits a near 1:1 ratio.

- Diagnostic Rule: Any molecular ion () or fragment ion retaining the bromine atom will appear as a "doublet" separated by 2 Da (X and) with approximately equal intensity.
- Validation: If a fragment ion loses this 1:1 pattern, the bromine atom has been ejected (neutral loss of or).

Hydrazine Lability

The hydrazine moiety (-NH-NH

) is electronically fragile. Under Electron Ionization (EI) or Collision-Induced Dissociation (CID), it typically undergoes:

- N–N Cleavage: Yielding amine radical cations.
- Denitrogenation: Loss of or hydrazine neutrals ().

Comparative Fragmentation Analysis

This section contrasts the performance and spectral signatures of 4-Bromophenylhydrazine against Phenylhydrazine (standard) and 4-Chlorophenylhydrazine (alternative halogen).

Table 1: Comparative MS Characteristics

Feature	Phenylhydrazine (Standard)	4-Bromophenylhydrazine (Target)	4-Chlorophenylhydrazine (Analog)
Molecular Ion ()	108 (Strong)	186 / 188 (1:1 Ratio)	142 / 144 (3:1 Ratio)
Primary Base Peak	92 ()	155 / 157 ()	111 / 113 ()
N-N Cleavage	Dominant. Forms Aniline (93).	Moderate. Forms 4-Bromoaniline (171/173).	Moderate. Forms 4-Chloroaniline (127/129).
Halogen Loss	N/A	Facile. Loss of yields 107.	Difficult. C-Cl bond is stronger; retention is high.
Denitrogenation	Loss of Benzene (78).	Loss of Bromophenyl cation.	Loss of Chlorophenyl cation.
Genotoxic Sensitivity	High (Derivatization often required).	High (Lower volatility aids detection).	High.

Key Analytical Insight

The "Bromine Switch": In Phenylhydrazine, the fragmentation is driven solely by the hydrazine group. In 4-Bromophenylhydrazine, the C–Br bond is weaker (approx. 280 kJ/mol) than the C–Cl bond (approx. 400 kJ/mol) or C–H bond. Consequently, competitive fragmentation occurs. You will often observe the loss of the bromine radical before or simultaneously with hydrazine degradation, creating a complex spectrum of "de-brominated" ions (e.g.,

107) that can be confused with non-halogenated impurities if high-resolution MS is not used.

Mechanistic Pathways

Understanding the causality of fragmentation is essential for structural elucidation. The following diagram maps the competing pathways for a generic Brominated Aryl Hydrazine under positive ionization.

Diagram 1: Fragmentation Mechanism of 4-Bromophenylhydrazine

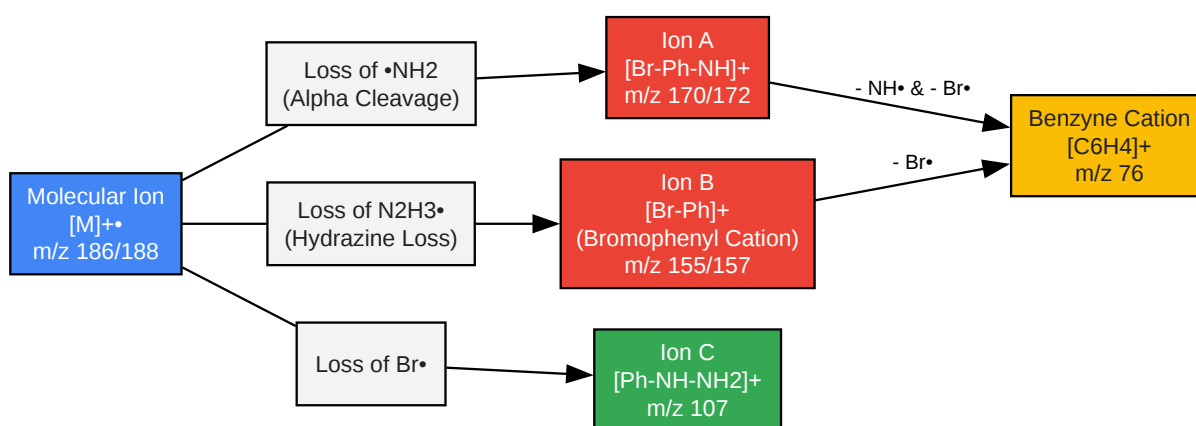

[Click to download full resolution via product page](#)

Caption: Competitive fragmentation pathways showing the divergence between hydrazine-driven cleavage (Red) and bromine-driven loss (Green).

Experimental Protocols

To achieve reproducible fragmentation patterns, the instability of the hydrazine group must be managed. Direct injection often leads to thermal degradation.

Protocol A: Derivatization for Stability (Recommended)

This protocol stabilizes the hydrazine moiety, allowing the brominated aromatic ring to be the primary determinant of the mass spectrum.

- Reagent Preparation: Prepare a 10 mM solution of Benzaldehyde or p-Tolualdehyde in Acetonitrile (ACN).

- Sample Reaction: Mix the brominated hydrazine sample (1 mg/mL) with the aldehyde solution in a 1:1.5 molar ratio.
- Incubation: Vortex for 30 seconds. Allow to stand at room temperature for 10 minutes. (Schiff base formation is rapid).
- LC-MS Analysis:
 - Column: C18 Reverse Phase (e.g., 2.1 x 50 mm, 1.7 μ m).
 - Mobile Phase: A: 0.1% Formic Acid in Water; B: ACN.
 - Gradient: 5% B to 95% B over 5 minutes.
 - Ionization: ESI Positive Mode.
- Result: The resulting Hydrazone will show a stable molecular ion () with the characteristic bromine doublet. Fragmentation will predominantly show cleavage of the C=N bond and loss of the aldehyde moiety.

Protocol B: Direct Infusion ESI-MS/MS (Structural Elucidation)

Use this for identifying unknown impurities where derivatization is not feasible.

- Solvent: Methanol/Water (50:50) + 5 mM Ammonium Formate (buffers pH to prevent auto-oxidation).
- Flow Rate: 10 μ L/min (Infusion).
- Source Settings:
 - Capillary Voltage: 3.0 kV.
 - Cone Voltage: Low (15-20 V). Critical: High cone voltage will prematurely fragment the N-N bond.

- Source Temp: < 100°C.
- MS/MS Acquisition:
 - Select the isotope (186) as the precursor.
 - Apply Collision Energy (CE) ramp: 10 -> 40 eV.
 - Look for: Transition from (Loss of) vs (Loss of).

Case Study: Distinguishing Isomers

A common challenge is distinguishing 4-Bromophenylhydrazine from its isomer 2-Bromo-4-methylpyridine-amine (similar mass).

Diagram 2: Workflow for Isomer Differentiation

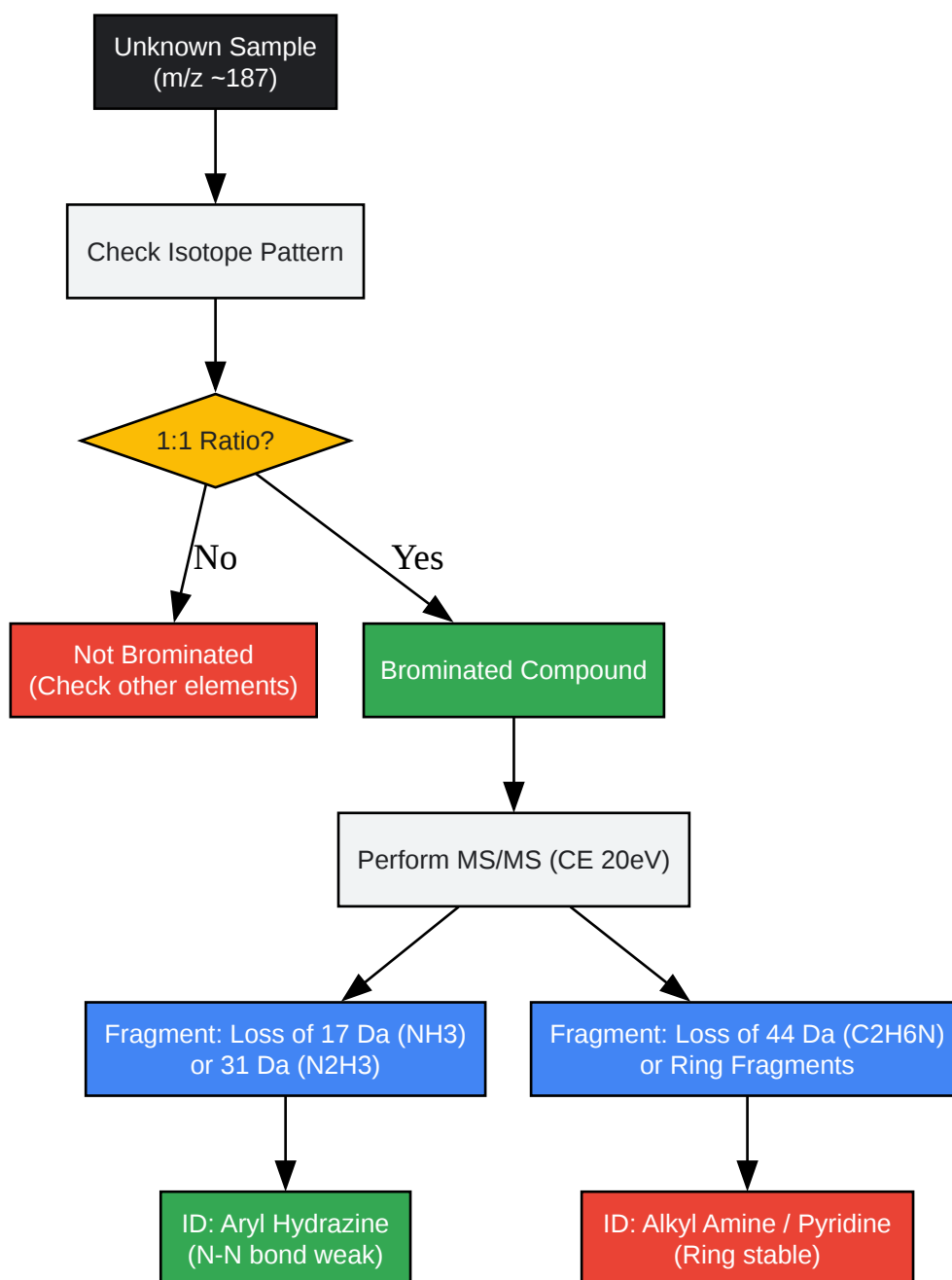

[Click to download full resolution via product page](#)

Caption: Logical decision tree for differentiating brominated hydrazines from isomeric amines using fragmentation logic.

References

- BenchChem. (2025).[1][2] In-Depth Technical Guide to the Mass Spectrometry Fragmentation of Benzaldehyde, 4-bromo-, hydrazone. Retrieved from

- European Chemicals Agency (ECHA). (2025). 4-Bromophenylhydrazine Registration Dossier. Retrieved from
- National Institutes of Health (NIH). (2025). PubChem Compound Summary for CID 12158: 4-Bromophenylhydrazine. Retrieved from
- Solanki, J., et al. (2025).[3] Analytical method development and validation for quantification of prominent genotoxic impurity in the marketed formulation of fluconazole using LC–MS/MS. Taylor & Francis. Retrieved from
- Wang, J., et al. (2016).[4][5] A simple and sensitive method to analyze genotoxic impurity hydrazine in pharmaceutical materials. Journal of Pharmaceutical and Biomedical Analysis. Retrieved from
- LibreTexts. (2023). Mass Spectrometry - Fragmentation Patterns. Retrieved from

Need Custom Synthesis?

BenchChem offers custom synthesis for rare earth carbides and specific isotopic labeling.

Email: info@benchchem.com or [Request Quote Online](#).

Sources

- [1. pdf.benchchem.com \[pdf.benchchem.com\]](https://pdf.benchchem.com)
- [2. pdf.benchchem.com \[pdf.benchchem.com\]](https://pdf.benchchem.com)
- [3. tandfonline.com \[tandfonline.com\]](https://tandfonline.com)
- [4. A simple and sensitive method to analyze genotoxic impurity hydrazine in pharmaceutical materials - PubMed \[pubmed.ncbi.nlm.nih.gov\]](https://pubmed.ncbi.nlm.nih.gov)
- [5. researchgate.net \[researchgate.net\]](https://researchgate.net)
- To cite this document: BenchChem. [Comparative Mass Spectrometry Guide: Fragmentation Dynamics of Brominated Aryl Hydrazines]. BenchChem, [2026]. [Online PDF]. Available at: [\[https://www.benchchem.com/product/b2404801/docs#comparative-mass-spectrometry-guide-fragmentation-dynamics-of-brominated-aryl-hydrazines\]](https://www.benchchem.com/product/b2404801/docs#comparative-mass-spectrometry-guide-fragmentation-dynamics-of-brominated-aryl-hydrazines)

Disclaimer & Data Validity:

The information provided in this document is for Research Use Only (RUO) and is strictly not intended for diagnostic or therapeutic procedures. While BenchChem strives to provide accurate protocols, we make no warranties, express or implied, regarding the fitness of this product for every specific experimental setup.

Technical Support: The protocols provided are for reference purposes. Unsure if this reagent suits your experiment?

Need Industrial/Bulk Grade? [Request Custom Synthesis Quote](#)

BenchChem

Our mission is to be the trusted global source of essential and advanced chemicals, empowering scientists and researchers to drive progress in science and industry.

Contact

Address: 3281 E Guasti Rd
Ontario, CA 91761, United States
Phone: (601) 213-4426
Email: info@benchchem.com

[Contact our Ph.D. Support Team for a compatibility check](#)