

Strategic Deployment of Fluorinated Benzyl Bromides: Synthesis, Reactivity, and Application

Author: BenchChem Technical Support Team. **Date:** May 2026

Compound of Interest

Compound Name: 4-(Bromomethyl)-1-ethoxy-2-fluorobenzene
CAS No.: 1441070-49-0
Cat. No.: B2391333

[Get Quote](#)

Executive Summary

Fluorinated benzyl bromides (F-BnBr) represent a cornerstone class of electrophilic building blocks in modern drug discovery. Their utility stems from a dual advantage: the chemical versatility of the benzylic bromide moiety—enabling rapid

diversifications—and the pharmacological benefits of the fluorine substituent, which modulates lipophilicity (

), metabolic stability, and protein-ligand binding interactions.

This guide provides a technical deep-dive into the selection, synthesis, and application of F-BnBr motifs.^[1] It moves beyond standard catalog listings to address the "why" and "how" of deploying these reagents to solve specific medicinal chemistry challenges, such as metabolic soft spots and potency cliffs.

The Strategic "Fluorine Effect" in Benzyl Linkers

The incorporation of fluorine into a benzyl linker is rarely arbitrary. It is a calculated decision to alter the physicochemical profile of a lead compound without significantly changing its steric footprint (Van der Waals radius of F

1.47 Å vs. H

1.20 Å).

Multiparameter Optimization (MPO)

- **Electronic Modulation:** The strong electronegativity of fluorine () pulls electron density from the aromatic ring. In a benzyl bromide, this inductively deactivates the ring but can increase the acidity of benzylic protons (shift), influencing the kinetics of subsequent nucleophilic substitutions.
- **Lipophilicity Tuning:** Monofluorination typically increases by ~ 0.2 – 0.3 units, enhancing membrane permeability. However, strategic positioning (e.g., ortho vs. para) can influence the overall dipole moment, sometimes counter-intuitively lowering due to polarity vectors canceling out.
- **Metabolic Blocking:** The C-F bond (approx. 116 kcal/mol) is resistant to Cytochrome P450 oxidation. Substituting a hydrogen with fluorine at positions prone to hydroxylation (metabolic "hot spots") significantly extends the half-life () of the drug.

Visualization: Metabolic Stability Logic

The following diagram illustrates how fluorination patterns dictate metabolic fate.

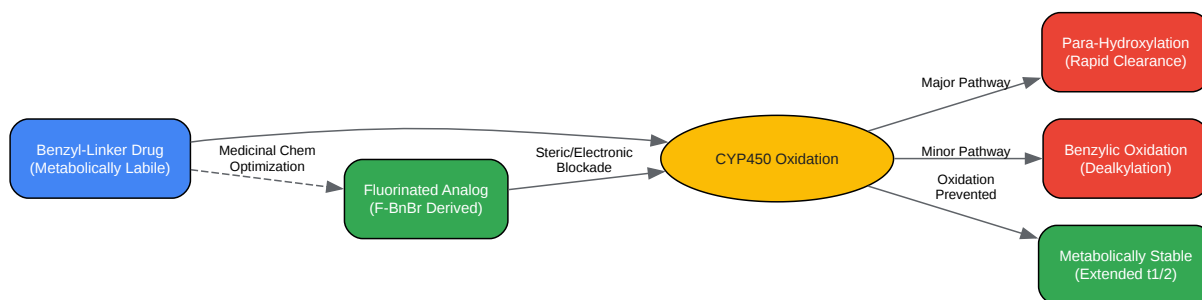

[Click to download full resolution via product page](#)

Figure 1: Strategic placement of fluorine (F-BnBr) blocks CYP450-mediated hydroxylation and dealkylation pathways.

Synthesis & Manufacturing of F-BnBr Building Blocks

While many F-BnBr reagents are commercially available, custom substitution patterns often require de novo synthesis. Two primary routes dominate, each with specific "gotchas" regarding regio-control and stability.

Route A: Radical Bromination (Wohl-Ziegler)

This is the industry standard for converting fluorinated toluenes to benzyl bromides.

- Reagents: N-Bromosuccinimide (NBS), Radical Initiator (AIBN or Benzoyl Peroxide).
- Solvent: Historically (banned/restricted); modern green alternatives include Methyl Acetate or Trifluorotoluene.
- Critical Control Point: Polybromination. Over-reaction leads to benzal dibromides (), which are difficult to separate.

- Solution: Use a slight deficit of NBS (0.95 eq) and stop the reaction at ~90% conversion.

Route B: Deoxybromination of Alcohols (Appel/PBr3)

Used when the starting material is a fluorinated benzyl alcohol (often reduced from a benzoic acid).

- Reagents:

or

(Appel Reaction).

- Advantage: Avoids radical side-reactions; strictly regioselective.
- Disadvantage: Atom economy is poor (waste).

Quantitative Comparison of Routes

Feature	Wohl-Ziegler (Radical)	Appel / PBr3 (Ionic)
Starting Material	Fluorotoluene	Fluorobenzyl Alcohol
Atom Economy	High	Low (High Mass Waste)
Selectivity	Moderate (Risk of)	High (Specific to -OH)
Scalability	Excellent (Industrial preferred)	Moderate (Waste disposal limits)
Cost	Low	Medium

Reactivity Profile & Synthetic Utility[2][3]

Fluorinated benzyl bromides are potent electrophiles (

). Their primary utility lies in introducing the fluorobenzyl group onto nucleophilic drug scaffolds (

).

Common Transformations

- N-Alkylation: Synthesis of secondary/tertiary amines. (e.g., Prasugrel intermediate).
- O-Alkylation (Williamson Ether): Synthesis of aryl-benzyl ethers. (e.g., Lapatinib).
- C-C Coupling: Conversion to Benzyl Zinc/Magnesium reagents for Negishi/Kumada coupling, or direct Suzuki coupling (though coupling can be tricky).

Handling & Stability (Safety Critical)

- Lachrymators: F-BnBr compounds are potent tear agents. All handling must occur in a functioning fume hood.
- Thermal Instability: Benzylic bromides can undergo autocatalytic decomposition (releasing HBr).
 - Storage: Store at 2–8°C over activated copper turnings (stabilizer) or to scavenge trace acid.

Experimental Protocol: Synthesis of a Lapatinib Intermediate

Objective: Synthesis of N-[3-chloro-4-[(3-fluorobenzyl)oxy]phenyl]-6-iodoquinazolin-4-amine via O-alkylation. Context: This protocol demonstrates the installation of the 3-fluorobenzyl moiety, a key pharmacophore in the breast cancer drug Lapatinib (Tykerb).

Reagents & Materials

- Electrophile: 3-Fluorobenzyl bromide (1.1 eq).
- Nucleophile: 4-(4-amino-6-iodoquinazolin-2-ylamino)-2-chlorophenol (1.0 eq).
- Base: Cesium Carbonate (

) (2.0 eq) – Selected for the "Cesium Effect" to enhance solubility and reactivity of the phenolate.

- Solvent: Anhydrous DMF or NMP.

Step-by-Step Methodology

- Preparation: In a flame-dried round-bottom flask under atmosphere, dissolve the chlorophenol nucleophile (10 mmol) in anhydrous DMF (50 mL).
- Deprotonation: Add (20 mmol) in one portion. Stir at RT for 30 mins. The mixture will likely change color (formation of phenoxide anion).
- Alkylation: Add 3-Fluorobenzyl bromide (11 mmol) dropwise via syringe.
 - Note: Dropwise addition prevents localized high concentrations that could lead to N-alkylation side products (though O-alkylation is favored for phenols).
- Reaction: Heat the mixture to 60°C. Monitor by TLC (Eluent: 5% MeOH in DCM).
 - Endpoint: Disappearance of the polar phenol spot ($R_f \sim 0.2$) and appearance of the less polar ether product ($R_f \sim 0.6$).
- Workup: Pour the mixture into ice-cold water (200 mL). The product should precipitate as a solid.
 - Purification: Collect by filtration, wash with water and cold EtOH. Recrystallize from acetonitrile.
 - Yield: Typically 85–92%.

Case Studies: Fluorinated Benzyl Motifs in Approved Drugs[4]

The incorporation of fluorinated benzyl groups is a recurring theme in medicinal chemistry, with specific examples highlighting the versatility of these building blocks.

Lapatinib (Tykerb)

- Indication: Breast Cancer (HER2/EGFR inhibitor).
- Structure: Contains a 3-fluorobenzyloxy group.
- Role of Fluorine: The 3-fluorobenzyl ether moiety occupies a hydrophobic pocket in the kinase domain. The fluorine atom engages in specific interactions with the protein backbone (e.g., weak H-bonding or dipole-dipole interactions), enhancing potency while blocking metabolic degradation of the benzyl ring.

Prasugrel (Effient)

- Indication: Antiplatelet agent (P2Y12 inhibitor).
- Structure: Contains a 2-fluorobenzyl group attached to a thienopyridine core.
- Role of Fluorine: The 2-fluorobenzyl group is critical for the prodrug's activation. While Prasugrel is a prodrug requiring metabolic activation (hydrolysis + oxidation), the fluorine substitution modulates the electronics of the pyridine ring, influencing the rate of active metabolite formation.

Safety & Handling Protocol

Fluorinated benzyl bromides are potent lachrymators (tear gas agents). Strict adherence to safety protocols is non-negotiable.

Hazard Identification

- Primary Hazard: Severe eye and respiratory irritation.
- Secondary Hazard: Skin corrosion/burns.[2]
- Stability: Benzylic bromides decompose over time, releasing HBr gas which can pressurize sealed containers.

Handling Procedures

- Engineering Controls: All weighing and manipulation must be performed inside a certified chemical fume hood.
- PPE: Chemical splash goggles, face shield, nitrile gloves (double-gloved recommended), and lab coat.
- Spill Response: Neutralize spills immediately with a dilute solution of sodium thiosulfate or sodium bicarbonate. Do not wipe with dry paper towels (aerosol generation).
- Storage: Store in a dedicated "Lachrymator" secondary container within a flammables cabinet. Keep refrigerated (2-8°C) to minimize decomposition.

References

- Meanwell, N. A. (2018). Fluorine and Fluorinated Motifs in the Design and Application of Bioisosteres for Drug Design. *Journal of Medicinal Chemistry*, 61(14), 5822–5880. Retrieved from [\[Link\]](#)
- Wood, E. R., et al. (2004). A Unique Structure for Epidermal Growth Factor Receptor Bound to GW572016 (Lapatinib). *Cancer Research*, 64(19), 6652–6659. Retrieved from [\[Link\]](#)
- Niitsu, Y., et al. (2008). Synthesis and Evaluation of 2-Fluorobenzyl Derivatives as Novel Antiplatelet Agents. *Bioorganic & Medicinal Chemistry Letters*, 18(5), 1563–1566. Retrieved from [\[Link\]](#)
- Occupational Safety and Health Administration (OSHA). (n.d.). Benzyl Bromide - Occupational Health Guideline. Retrieved from [\[Link\]](#)

Need Custom Synthesis?

BenchChem offers custom synthesis for rare earth carbides and specific isotopic labeling.

Email: info@benchchem.com or [Request Quote Online](#).

Sources

- 1. pdf.benchchem.com [pdf.benchchem.com]

- [2. fishersci.com \[fishersci.com\]](https://fishersci.com)
- To cite this document: BenchChem. [Strategic Deployment of Fluorinated Benzyl Bromides: Synthesis, Reactivity, and Application]. BenchChem, [2026]. [Online PDF]. Available at: [<https://www.benchchem.com/product/b2391333/docs#strategic-deployment-of-fluorinated-benzyl-bromides-synthesis-reactivity-and-application>]

Disclaimer & Data Validity:

The information provided in this document is for Research Use Only (RUO) and is strictly not intended for diagnostic or therapeutic procedures. While BenchChem strives to provide accurate protocols, we make no warranties, express or implied, regarding the fitness of this product for every specific experimental setup.

Technical Support: The protocols provided are for reference purposes. Unsure if this reagent suits your experiment?

Need Industrial/Bulk Grade? [Request Custom Synthesis Quote](#)

BenchChem

Our mission is to be the trusted global source of essential and advanced chemicals, empowering scientists and researchers to drive progress in science and industry.

Contact

Address: 3281 E Guasti Rd
Ontario, CA 91761, United States
Phone: (601) 213-4426
Email: info@benchchem.com

[Contact our Ph.D. Support Team for a compatibility check](#)