

How to prevent Arnicolide C degradation in solution

Author: BenchChem Technical Support Team. **Date:** December 2025

Compound of Interest

Compound Name: ArnicolideC

Cat. No.: B2391175

[Get Quote](#)

Technical Support Center: Arnicolide C Stability

This technical support center provides guidance for researchers, scientists, and drug development professionals on preventing the degradation of Arnicolide C in solution. The following information is compiled from stability studies of sesquiterpene lactones, the chemical class to which Arnicolide C belongs.

Frequently Asked Questions (FAQs)

Q1: What are the primary factors that cause Arnicolide C degradation in solution?

A1: The primary factors contributing to the degradation of sesquiterpene lactones like Arnicolide C in solution are pH, temperature, and light exposure. The solvent used can also play a significant role in stability.

Q2: How does pH affect the stability of Arnicolide C?

A2: Sesquiterpene lactones exhibit varying stability at different pH levels. Generally, neutral to alkaline conditions ($\text{pH} \geq 7.4$) can lead to the degradation of certain sesquiterpene lactones, particularly those with side chains.[1] Acidic to neutral pH (around 5.5) tends to be more favorable for the stability of these compounds.[1] It is crucial to determine the optimal pH for your specific experimental conditions.

Q3: What is the recommended storage temperature for Arnicolide C solutions?

A3: For long-term storage, Arnicolide C solid should be kept desiccated at -20°C .^[2] For solutions, it is recommended to store them at low temperatures, such as $2-8^{\circ}\text{C}$ or frozen, to minimize degradation.^[3] Studies on similar compounds in Arnica tincture have shown a significant decrease in sesquiterpene lactone content at higher storage temperatures ($+25^{\circ}\text{C}$ and $+30^{\circ}\text{C}$) compared to $+4^{\circ}\text{C}$.^[4]

Q4: Is Arnicolide C sensitive to light?

A4: Yes, many sesquiterpene lactones are known to be photolabile.^[5] Exposure to UV light can lead to degradation.^[5] Therefore, it is recommended to store Arnicolide C solutions in the dark or in amber vials to protect them from light.^[3]

Q5: What solvents are recommended for dissolving Arnicolide C?

A5: Arnicolide C is soluble in chloroform, dichloromethane, ethyl acetate, DMSO, and acetone.^[2] The choice of solvent can impact stability. For instance, in an Arnica tincture, the presence of ethanol was shown to cause degradation of sesquiterpene lactones over time.^[4] It is advisable to use aprotic solvents and to prepare solutions fresh whenever possible.

Troubleshooting Guide

Issue	Possible Cause	Recommended Solution
Loss of compound activity or inconsistent results.	Degradation of Arnicolide C in the stock or working solution.	<ol style="list-style-type: none">1. Verify Storage Conditions: Ensure the solid compound is stored at -20°C and solutions are kept at 2-8°C or frozen, protected from light.2. Check Solution Age: Prepare fresh solutions for each experiment, especially for aqueous buffers.3. Evaluate Solvent: If using protic solvents like ethanol or methanol, consider switching to aprotic solvents like DMSO or acetone for stock solutions.4. Control pH: For aqueous solutions, buffer the solution to a slightly acidic pH (e.g., pH 5.5) to enhance stability.^[1]
Appearance of unexpected peaks in chromatography (HPLC, LC-MS).	Formation of degradation products.	<ol style="list-style-type: none">1. Analyze Degradation Pathway: The new peaks could correspond to hydrolysis or other modifications of the lactone ring or side chains.^[1]2. Optimize Conditions: Implement the preventative measures outlined above (temperature, light, pH, and solvent) to minimize the formation of these impurities.3. Purify Sample: If degradation has already occurred, repurification of the sample may be necessary.
Precipitation of Arnicolide C in aqueous solutions.	Poor solubility in aqueous buffers.	<ol style="list-style-type: none">1. Use a Co-solvent: Prepare a concentrated stock solution in an organic solvent like DMSO

and then dilute it into the aqueous buffer. Ensure the final concentration of the organic solvent is compatible with your experimental system.

2. Check Concentration: Do not exceed the solubility limit of Arnicolide C in the chosen solvent system.

Quantitative Data Summary

Table 1: Effect of Temperature on Sesquiterpene Lactone Content in Arnica Tincture (3-Year Storage)

Storage Temperature	Decrease in Sesquiterpene Lactone Content
+4°C	13%
+25°C	32%
+30°C	37%

Data adapted from a study on the stability of sesquiterpene lactones in Arnica tincture.[\[4\]](#)

Table 2: Stability of Sesquiterpene Lactones at Different pH and Temperatures (96 hours)

Compound Type	pH	Temperature	Stability
Sesquiterpene lactones with a side chain	7.4	37°C	Loss of side chain
Sesquiterpene lactones with a side chain	5.5	25°C / 37°C	Stable
Sesquiterpene lactones without a side chain	5.5 and 7.4	25°C / 37°C	Stable

Data from a study on the stability of various sesquiterpene lactones.^[1]

Experimental Protocols

Protocol 1: Preparation and Storage of Arnicolide C Stock Solution

- Materials:
 - Arnicolide C (solid)
 - Anhydrous Dimethyl Sulfoxide (DMSO)
 - Amber glass vial with a screw cap
 - Calibrated analytical balance
 - Pipettes
- Procedure:

1. Equilibrate the vial of solid Arnicolide C to room temperature before opening to prevent moisture condensation.
2. Weigh the desired amount of Arnicolide C using a calibrated analytical balance.
3. Dissolve the weighed Arnicolide C in the appropriate volume of anhydrous DMSO to achieve the desired stock concentration (e.g., 10 mM).
4. Ensure complete dissolution by vortexing briefly.
5. Store the stock solution in a tightly sealed amber glass vial at -20°C.

Protocol 2: Preparation of Working Solutions in Aqueous Buffer

- Materials:
 - Arnicolide C stock solution (from Protocol 1)
 - Aqueous buffer (e.g., Phosphate-Buffered Saline, pH adjusted as needed)
 - Sterile microcentrifuge tubes
- Procedure:
 1. Thaw the Arnicolide C stock solution at room temperature.
 2. Dilute the stock solution with the aqueous buffer to the final desired concentration immediately before use.
 3. To minimize degradation in aqueous media, it is recommended to prepare only the volume needed for the experiment.
 4. If the experiment requires a specific pH, ensure the buffer is adjusted accordingly. For potentially improved stability, a slightly acidic buffer (pH 5.5-6.5) can be tested.^[1]
 5. Keep the working solution on ice and protected from light throughout the experiment.

Visualizations

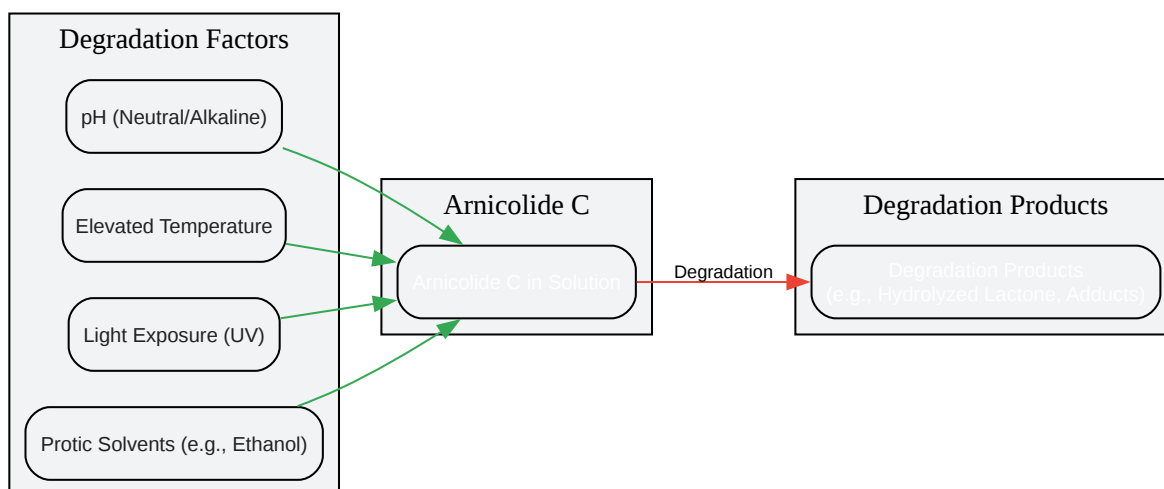

[Click to download full resolution via product page](#)

Caption: Factors influencing the degradation of Arnicolide C in solution.

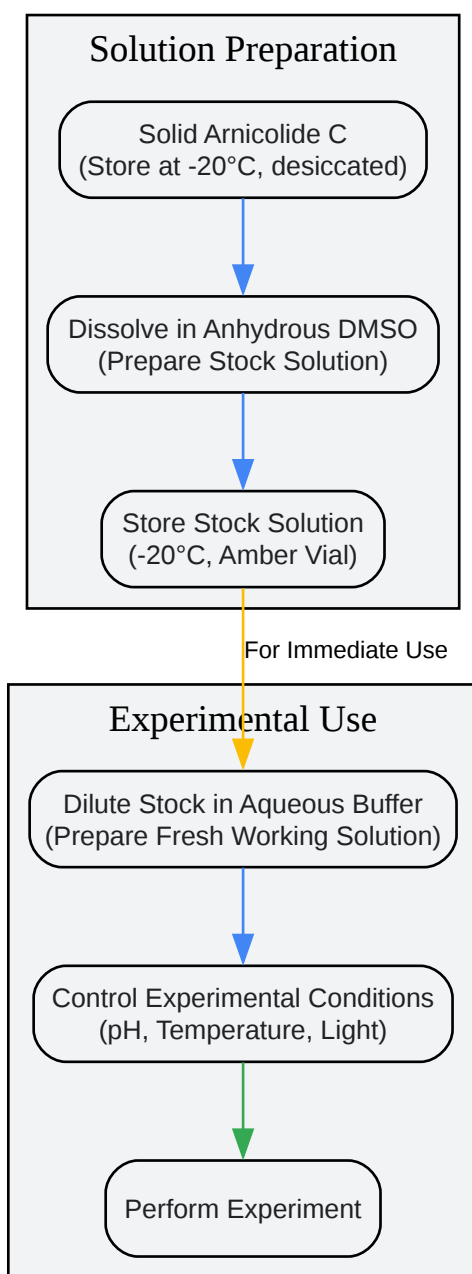

[Click to download full resolution via product page](#)

Caption: Recommended workflow for handling Arnicolide C solutions.

Need Custom Synthesis?

BenchChem offers custom synthesis for rare earth carbides and specific isotopic labeling.

Email: info@benchchem.com or [Request Quote Online](#).

References

- 1. researchgate.net [researchgate.net]
- 2. Arnicolide C | CAS:34532-67-7 | Sesquiterpenoids | High Purity | Manufacturer BioCrick [biocrick.com]
- 3. static.cymitquimica.com [static.cymitquimica.com]
- 4. On the stability of sesquiterpene lactones in the officinal Arnica tincture of the German pharmacopoeia - PubMed [pubmed.ncbi.nlm.nih.gov]
- 5. chimia.ch [chimia.ch]
- To cite this document: BenchChem. [How to prevent Arnicolide C degradation in solution]. BenchChem, [2025]. [Online PDF]. Available at: [https://www.benchchem.com/product/b2391175#how-to-prevent-arnicolide-c-degradation-in-solution]

Disclaimer & Data Validity:

The information provided in this document is for Research Use Only (RUO) and is strictly not intended for diagnostic or therapeutic procedures. While BenchChem strives to provide accurate protocols, we make no warranties, express or implied, regarding the fitness of this product for every specific experimental setup.

Technical Support: The protocols provided are for reference purposes. Unsure if this reagent suits your experiment? [[Contact our Ph.D. Support Team for a compatibility check](#)]

Need Industrial/Bulk Grade? [Request Custom Synthesis Quote](#)

BenchChem

Our mission is to be the trusted global source of essential and advanced chemicals, empowering scientists and researchers to drive progress in science and industry.

Contact

Address: 3281 E Guasti Rd
Ontario, CA 91761, United States
Phone: (601) 213-4426
Email: info@benchchem.com