

The Analytical Imperative: Unambiguous Identification of C₁₂H₁₅FO₂

Author: BenchChem Technical Support Team. **Date:** April 2026

Compound of Interest

Compound Name: *tert-Butyl 2-(4-fluorophenyl)acetate*
CAS No.: 68825-45-6
Cat. No.: B2384926

[Get Quote](#)

In any research or drug development pipeline, the definitive structural confirmation of a newly synthesized compound is a critical milestone. A molecule with the elemental formula C₁₂H₁₅FO₂ represents a typical candidate that requires rigorous characterization. The primary challenge is not just to detect the molecule, but to confirm its elemental composition with unshakable confidence, distinguishing it from countless other potential isobaric (same nominal mass) and isomeric (same elemental formula, different structure) compounds.

To achieve this, the first step is to calculate the theoretical exact mass of the molecule based on the most abundant isotopes of its constituent elements.

- Carbon (¹²C): 12.000000 Da x 12 = 144.000000 Da
- Hydrogen (¹H): 1.007825 Da x 15 = 15.117375 Da
- Fluorine (¹⁹F): 18.998403 Da x 1 = 18.998403 Da
- Oxygen (¹⁶O): 15.994915 Da x 2 = 31.989830 Da

- Monoisotopic Mass: 209.105608 Da

This calculated value is the benchmark against which experimental measurements are compared. High-resolution mass spectrometry is the premier technique for performing this measurement with the required precision.[1]

The Gold Standard: High-Resolution Mass Spectrometry (HRMS)

HRMS is an analytical technique used to determine the exact molecular masses of compounds, making it ideal for identifying the structures of small organic molecules.[2] Unlike low-resolution mass spectrometry, which measures mass to the nearest whole number (nominal mass), HRMS instruments can achieve mass accuracies of less than 5 parts-per-million (ppm), and often below 1 ppm.[3] This extraordinary precision allows for the confident determination of a molecule's elemental formula.[1]

Modern HRMS platforms, such as Quadrupole Time-of-Flight (Q-TOF) and Orbitrap-based systems, provide both high resolution and high mass accuracy.[4][5][6]

- Resolution is the ability of the mass spectrometer to distinguish between ions with very similar mass-to-charge ratios (m/z).[7][8]
- Mass Accuracy is the closeness of the measured mass to the theoretical, calculated mass.[7]

Experimental Workflow for C₁₂H₁₅FO₂ Analysis

A robust and self-validating workflow is essential for acquiring high-quality HRMS data. This typically involves coupling a liquid chromatography (LC) system to the HRMS instrument (LC-HRMS) to separate the analyte from impurities or a complex sample matrix before analysis.[9]

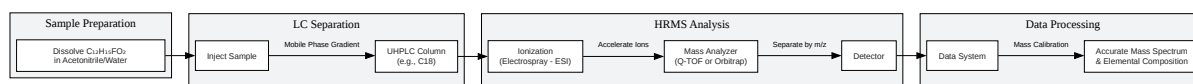

[Click to download full resolution via product page](#)

Caption: General workflow for LC-HRMS analysis of a small molecule.

Detailed Experimental Protocol:

- Sample Preparation:
 - Rationale: To ensure the analyte is fully dissolved and compatible with the LC mobile phase, preventing precipitation and ensuring efficient ionization.
 - Protocol: Prepare a 1 mg/mL stock solution of the C₁₂H₁₅FO₂ sample in acetonitrile. Dilute this stock solution to a final concentration of 1 µg/mL using a 50:50 mixture of water and acetonitrile containing 0.1% formic acid. The acid is added to promote protonation and enhance signal in positive ion mode.
- LC-HRMS System and Conditions:
 - Rationale: Chromatographic separation is crucial to isolate the target compound from any starting materials, byproducts, or matrix components, which could interfere with accurate mass measurement.[10]
 - System: A UHPLC system coupled to a Q-TOF or Orbitrap mass spectrometer.
 - Column: C18 reversed-phase column (e.g., 2.1 mm x 50 mm, 1.7 µm particle size).
 - Mobile Phase A: Water + 0.1% Formic Acid.
 - Mobile Phase B: Acetonitrile + 0.1% Formic Acid.
 - Gradient: Start at 5% B, ramp to 95% B over 5 minutes, hold for 2 minutes, then return to initial conditions and equilibrate.
 - Flow Rate: 0.4 mL/min.
 - Injection Volume: 2 µL.
- Instrument Calibration:

- Rationale: This is the most critical step for ensuring mass accuracy. The instrument's m/z scale is calibrated against a known reference compound or mixture that provides ions of precisely known masses across the desired measurement range.[10] This calibration corrects for any instrumental drift.
- Protocol: Perform an external calibration prior to the analysis sequence using the instrument manufacturer's recommended calibration solution. For the highest accuracy, infuse a low concentration of a reference standard (internal calibrant) continuously during the analysis to allow for real-time mass correction.
- HRMS Data Acquisition:
 - Rationale: Data is acquired in full-scan mode to capture all ions within a specified mass range, allowing for retrospective data analysis.[11] Both positive and negative ionization modes are often tested to determine which provides a better signal for the compound of interest.
 - Ionization Mode: Electrospray Ionization (ESI), Positive Mode ([M+H]⁺).
 - Scan Range: m/z 50–500.
 - Resolution Setting: >40,000 FWHM (Full Width at Half Maximum).[3]
 - Tandem MS (MS/MS): For structural information, set the instrument to perform data-dependent acquisition (DDA), where the most intense ions in a full scan (like our target m/z 210.1128 for [M+H]⁺) are automatically selected for fragmentation.

Interpreting the HRMS Data for C₁₂H₁₅FO₂

The primary output is a high-resolution mass spectrum. The goal is to find the experimentally measured m/z that corresponds to the protonated molecule, [C₁₂H₁₅FO₂ + H]⁺, which has a theoretical exact mass of 210.112883 Da.

Table 1: Simulated HRMS Data for C₁₂H₁₅FO₂

Ion Species	Theoretical m/z	Observed m/z	Mass Error (ppm)	Relative Abundance (%)
[M+H] ⁺	210.11288	210.11267	-1.0	100.0
[M+1+H] ⁺	211.11626	211.11601	-1.2	13.2
[M+2+H] ⁺	212.11963	212.11935	-1.3	0.9

The data in Table 1 shows an observed mass with an error of just -1.0 ppm. This extremely low error provides very high confidence that the elemental formula is indeed C₁₂H₁₅FO₂. The observed isotopic pattern, with the correct relative abundances for the M+1 (primarily from ¹³C) and M+2 peaks, further validates this assignment.

Structural Elucidation with MS/MS:

While HRMS confirms the elemental formula, it does not reveal the specific isomeric structure. For this, tandem mass spectrometry (MS/MS) is used. The [M+H]⁺ ion is isolated and fragmented, and the resulting fragment ions provide clues about the molecule's structure.

For a hypothetical structure, 4-((4-fluorophenyl)methoxy)butanal, a plausible fragmentation pathway could be the loss of the butanal side chain.

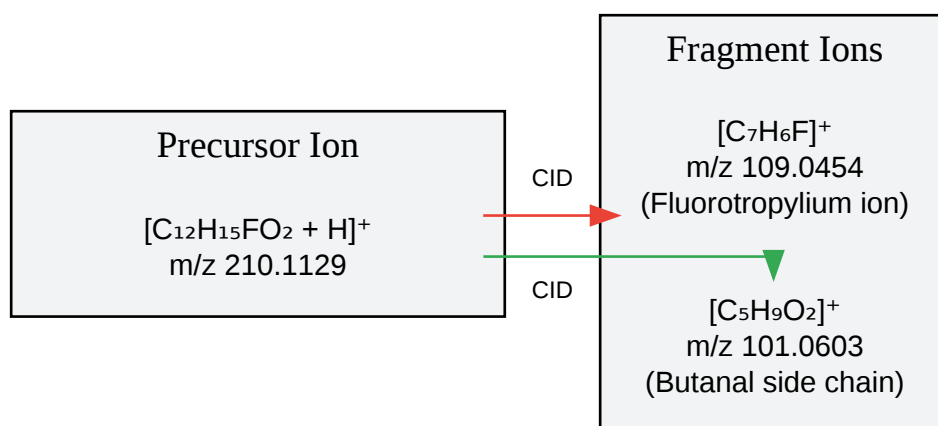

[Click to download full resolution via product page](#)

Caption: Hypothetical MS/MS fragmentation of a C₁₂H₁₅FO₂ isomer.

A Comparative Landscape of Analytical Techniques

While HRMS is powerful, it is part of a broader analytical toolkit. Its performance is best understood in comparison to other common techniques in pharmaceutical and chemical analysis.[\[12\]](#)

Table 2: Comparison of Key Analytical Techniques

Feature	High-Resolution MS (HRMS)	Nominal Mass MS (e.g., Single Quad)	Nuclear Magnetic Resonance (NMR)	HPLC-UV
Primary Output	Accurate m/z, elemental formula, structure fragments	Nominal m/z, structure fragments	Definitive chemical structure and connectivity	Analyte retention time and UV absorbance
Selectivity	Extremely High	Moderate to High	Very High	Low to Moderate
Sensitivity	High (pg to fg)	Very High (fg to ag)	Low (µg to mg)	Moderate (ng to µg)
Key Advantage	Unambiguous elemental formula confirmation	Excellent for targeted quantification (SRM/MRM)	Gold standard for de novo structure elucidation	Robust, simple, and reliable for quantification
Key Limitation	Cannot distinguish isomers without chromatography/MSn	Cannot determine elemental formula; prone to isobaric interference	Low throughput; requires pure, concentrated sample	Cannot identify unknowns; requires a chromophore
Typical Use	Formula confirmation, metabolomics, impurity ID [13]	Routine targeted quantification [14]	Absolute proof of structure for novel compounds	Routine purity checks and quantification of knowns [12]

When to Use Which Technique?

The choice of technique depends on the analytical question.[15]

- For initial confirmation of a new molecule's identity: HRMS is the fastest and most efficient method to confirm that the correct elemental formula has been synthesized.
- For definitive, unambiguous proof of a novel structure: NMR spectroscopy is indispensable. It provides detailed information about the carbon-hydrogen framework and the connectivity of atoms.
- For routine, high-throughput quantification of a known compound: A triple quadrupole (a type of nominal mass MS) or an HPLC-UV system is often more cost-effective and faster.[16] HPLC-UV is simple and robust but requires the compound to absorb UV light and is less selective than MS.[12]

These techniques are not mutually exclusive; they are synergistic. A typical workflow in drug discovery involves synthesizing a compound, confirming its elemental formula with HRMS, elucidating its exact structure with NMR, and then developing an HPLC-UV or triple quadrupole MS method for routine quality control and quantification.

Conclusion: The Strategic Value of HRMS

For the initial, high-confidence characterization of a novel compound like $C_{12}H_{15}FO_2$, High-Resolution Mass Spectrometry is an unparalleled tool. Its ability to provide a highly accurate mass measurement allows for the rapid and unambiguous determination of the compound's elemental formula, a foundational piece of data that guides all subsequent stages of research and development. While other techniques like NMR are essential for complete structural elucidation, HRMS provides the initial "green light" with exceptional speed and sensitivity. By integrating HRMS early into analytical workflows, researchers can accelerate project timelines, reduce ambiguity, and make more informed decisions with a higher degree of scientific certainty.

References

- Dargan, D., & Smith, C. (2015). Quadrupole Time-of-Flight Mass Spectrometry: A Paradigm Shift in Toxicology Screening Applications. PMC. [[Link](#)]

- Scribd. Analytical Techniques Comparison Final. [[Link](#)]
- Wikipedia. Time-of-flight mass spectrometry. [[Link](#)]
- Laganowsky, A., Reading, E., et al. (2016). High-resolution mass spectrometry of small molecules bound to membrane proteins. PMC. [[Link](#)]
- Mettler Toledo. (2025). Comparison of Optical Spectroscopy Techniques for Pharmaceutical Analysis. [[Link](#)]
- Biopharmaceutical Technology. (2022). High Performance Mass Spectrometry for Small Molecule and Protein Applications. [[Link](#)]
- Chernushevich, I. V., Loboda, A. V., & Thomson, B. A. (2001). An introduction to quadrupole-time-of-flight mass spectrometry. PubMed. [[Link](#)]
- ZefSci. (2024). Choosing the Right Mass Spectrometry for Small Molecules. [[Link](#)]
- Fiveable. Accurate Mass Measurement Definition. [[Link](#)]
- Chromatography Online. (2020). Comparing the Capabilities of Time-of-Flight and Quadrupole Mass Spectrometers. [[Link](#)]
- LinkedIn. (2024). Pharmaceutical Analysis. [[Link](#)]
- The Royal Society of Chemistry. Methodology for Accurate Mass Measurement of Small Molecules. [[Link](#)]
- bioRxiv. (2020). MQ: Tool for HR-AM Based Quantitative Analysis for Direct MS Workflow. [[Link](#)]
- Shimadzu. (2019). On the Accurate Understanding of Mass Measurement Accuracy in Q-TOF MS. [[Link](#)]
- Spectroscopy Online. (2020). Dealing With the Masses: A Tutorial on Accurate Masses, Mass Uncertainties, and Mass Defects. [[Link](#)]
- Raptor Scientific. The Seven Secrets of Accurate Mass Properties Measurement. [[Link](#)]

- ResolveMass Laboratories Inc. (2025). High-Resolution Mass Spectrometry FAQs. [\[Link\]](#)
- Schymanski, E. L., et al. (2021). Guide to Semi-Quantitative Non-Targeted Screening Using LC/ESI/HRMS. PMC. [\[Link\]](#)

Need Custom Synthesis?

BenchChem offers custom synthesis for rare earth carbides and specific isotopic labeling.

Email: info@benchchem.com or [Request Quote Online](#).

Sources

- 1. [fiveable.me](#) [[fiveable.me](#)]
- 2. [measurlabs.com](#) [[measurlabs.com](#)]
- 3. [chromatographyonline.com](#) [[chromatographyonline.com](#)]
- 4. Quadrupole Time-of-Flight Mass Spectrometry: A Paradigm Shift in Toxicology Screening Applications - PMC [[pmc.ncbi.nlm.nih.gov](#)]
- 5. Re-defining Productivity for Small Molecule, High-resolution Mass Spectrometry Analysis - AnalyteGuru [[thermofisher.com](#)]
- 6. High-resolution mass spectrometry of small molecules bound to membrane proteins - PMC [[pmc.ncbi.nlm.nih.gov](#)]
- 7. [lcms.cz](#) [[lcms.cz](#)]
- 8. [spectroscopyonline.com](#) [[spectroscopyonline.com](#)]
- 9. Guide to Semi-Quantitative Non-Targeted Screening Using LC/ESI/HRMS - PMC [[pmc.ncbi.nlm.nih.gov](#)]
- 10. [rsc.org](#) [[rsc.org](#)]
- 11. [documents.thermofisher.com](#) [[documents.thermofisher.com](#)]
- 12. [scribd.com](#) [[scribd.com](#)]
- 13. MQ: Tool for HR-AM Based Quantitative Analysis for Direct MS Workflow | bioRxiv [[biorxiv.org](#)]
- 14. [zefsci.com](#) [[zefsci.com](#)]
- 15. [americanpharmaceuticalreview.com](#) [[americanpharmaceuticalreview.com](#)]

- [16. spectroscopyonline.com \[spectroscopyonline.com\]](https://spectroscopyonline.com)
- To cite this document: BenchChem. [The Analytical Imperative: Unambiguous Identification of C₁₂H₁₅FO₂]. BenchChem, [2026]. [Online PDF]. Available at: [<https://www.benchchem.com/product/b2384926/docs#the-analytical-imperative-unambiguous-identification-of-c-h-fo>]

Disclaimer & Data Validity:

The information provided in this document is for Research Use Only (RUO) and is strictly not intended for diagnostic or therapeutic procedures. While BenchChem strives to provide accurate protocols, we make no warranties, express or implied, regarding the fitness of this product for every specific experimental setup.

Technical Support: The protocols provided are for reference purposes. Unsure if this reagent suits your experiment?

Need Industrial/Bulk Grade? [Request Custom Synthesis Quote](#)

BenchChem

Our mission is to be the trusted global source of essential and advanced chemicals, empowering scientists and researchers to drive progress in science and industry.

Contact

Address: 3281 E Guasti Rd

Ontario, CA 91761, United States

Phone: (601) 213-4426

Email: info@benchchem.com

[Contact our Ph.D. Support Team for a compatibility check](#)