

Technical Support Center: Cyanation of 4-Chloro-1-Methylimidazole

Author: BenchChem Technical Support Team. **Date:** May 2026

Compound of Interest

Compound Name: 4-chloro-1-methyl-1H-imidazole-5-carbonitrile

CAS No.: 54711-54-5

Cat. No.: B2378128

[Get Quote](#)

Welcome to the Advanced Synthesis Support Module. Topic: Optimization of C–C Bond Formation via Cyanation Substrate: 4-Chloro-1-methylimidazole (CAS: 13523-98-3) Target Product: 1-Methylimidazole-4-carbonitrile (CAS: 3622-04-6)[1]

Executive Summary & Reaction Strategy

The Challenge: Cyanating 4-chloro-1-methylimidazole presents a specific kinetic challenge. Unlike 2-haloimidazoles (which are electron-deficient and reactive toward nucleophilic attack) or 5-haloimidazoles (sterically accessible), the 4-position is electronically neutral to slightly electron-rich.[1] Furthermore, the chlorine atom is a reluctant leaving group compared to bromine or iodine, and the N3 nitrogen atom is a potent ligand that can poison transition metal catalysts.

The Solution Architecture: We recommend a Palladium-Catalyzed Cross-Coupling (Method A) as the primary protocol due to milder conditions and cleaner profiles. The classical Rosenmund-von Braun (Method B) is reserved as a fallback for large-scale, cost-sensitive batches where high heat is tolerable.[1]

Decision Matrix: Selecting Your Protocol

Use this logic flow to select the correct experimental path for your constraints.

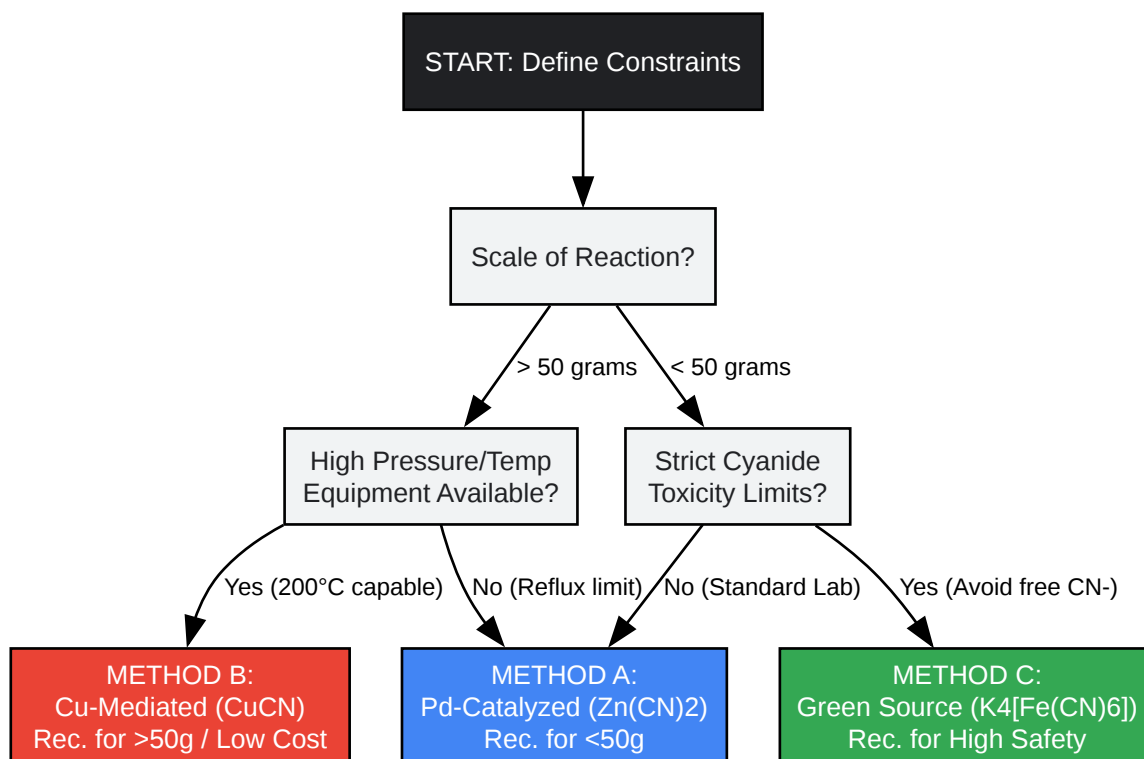

[Click to download full resolution via product page](#)

Figure 1: Protocol Selection Logic. Choose Method A for research scale to minimize purification difficulty.

Detailed Protocols

Method A: Palladium-Catalyzed Cyanation (Recommended)

Best for: High yields, mild conditions (80–100°C), research scale.

The Mechanism: This relies on the oxidative addition of Pd(0) into the C(sp²)–Cl bond. Because the C–Cl bond is strong, we utilize XPhos or SPhos ligands.[1] These bulky, electron-rich biaryl phosphines facilitate oxidative addition and prevent the imidazole N3 from binding to the palladium center (catalyst poisoning).

Reagents:

- Substrate: 4-Chloro-1-methylimidazole (1.0 equiv)
- Source: Zinc Cyanide ($\text{Zn}(\text{CN})_2$) (0.6 equiv) — Note: $\text{Zn}(\text{CN})_2$ delivers 2 CN groups.[1]
- Catalyst: $\text{Pd}_2(\text{dba})_3$ (2 mol%) or $\text{Pd}(\text{OAc})_2$ (4 mol%)[1]
- Ligand: XPhos or SPhos (4–8 mol%)
- Additive: Zn powder (10 mol%) — Critical for keeping Pd in the active (0) state.
- Solvent: DMAc (N,N-Dimethylacetamide) or DMF (anhydrous).[1]

Step-by-Step:

- Degassing (Crucial): Charge a reaction vial with the substrate, $\text{Zn}(\text{CN})_2$, Pd source, Ligand, and Zn powder. Seal the vial. Evacuate and backfill with Argon/Nitrogen 3 times.[1] Oxygen kills this catalytic cycle.[1]
- Solvent Addition: Add anhydrous DMAc via syringe.
- Reaction: Heat to 95–100°C for 4–16 hours.
 - Checkpoint: Monitor by LCMS.[1] Look for the nitrile mass ($M^+ = 107.1$).[1]
- Quench: Cool to RT. Dilute with EtOAc.
- Workup: Wash with 1M Ammonium Hydroxide (NH_4OH) or 10% ethylenediamine solution.[1] This complexes the Zinc/Palladium byproducts, pulling them into the aqueous phase.

Method B: Rosenmund-von Braun (Copper Mediated)

Best for: Cost reduction, scale-up, robust substrates.[1]

The Mechanism: A harsh nucleophilic substitution requiring high activation energy.[1] The mechanism involves the formation of a cuprate intermediate.

Reagents:

- Substrate: 4-Chloro-1-methylimidazole (1.0 equiv)
- Source: CuCN (1.5 – 2.0 equiv)[1]
- Solvent: NMP or DMF.

Step-by-Step:

- Setup: Combine substrate and CuCN in NMP.
- Reaction: Heat to 160–180°C. This high temperature is non-negotiable for chloro-imidazoles. [1]
- Workup (The "FeCl₃ Method"):
 - Cool to 60°C.
 - Pour the mixture into a solution of FeCl₃ (3 equiv) in 0.1 M HCl.
 - Why? CuCN forms tight complexes with the product.[1] Iron(III) oxidizes the Cu(I) to Cu(II), breaking the complex and releasing the nitrile product into the organic phase.
 - Extract with EtOAc.[1]

Troubleshooting Guide (FAQ)

Issue 1: "My reaction stalls at 30-50% conversion."

Diagnosis: Catalyst Deactivation. Root Cause: The imidazole N3 nitrogen is coordinating to the Palladium, forming a stable, non-reactive complex (Pd-N bond). Corrective Actions:

- Switch Ligands: Move to XPhos or BrettPhos.[1] The sheer bulk of these ligands sterically hinders the N3 approach while allowing the C-Cl bond to access the metal center [1].
- Increase Temperature: Bump from 80°C to 100°C to increase the reversibility of the N-Pd binding.
- Add Zinc Dust: Add 5-10 mol% activated Zn dust.[1] This reduces any oxidized Pd(II) back to active Pd(0).[1]

Issue 2: "I see a new peak with Mass M+18 (Amide)."

Diagnosis: Nitrile Hydrolysis.[1] Root Cause: Water presence in the solvent.[1] At high temperatures with Lewis acids (Zn or Cu), the nitrile hydrates to the primary amide ($-\text{CONH}_2$).

Corrective Actions:

- Dry Solvents: Use DMF/DMAc from a fresh bottle or dry over 4Å molecular sieves for 24 hours.
- Schlenk Technique: Ensure the reaction is run under positive Nitrogen pressure.

Issue 3: "The Copper reaction (Method B) turned into a black tar/sludge."

Diagnosis: Thermal Polymerization.[1] Root Cause: 180°C is too hot for prolonged periods, causing imidazole ring degradation.[1] Corrective Actions:

- Microwave Assist: Switch to microwave heating (180°C for 30 mins). This provides the energy burst needed for activation without the prolonged thermal soak that causes tarring.[1]

Visualizing the Troubleshooting Logic

Use this flowchart to diagnose stalled reactions.

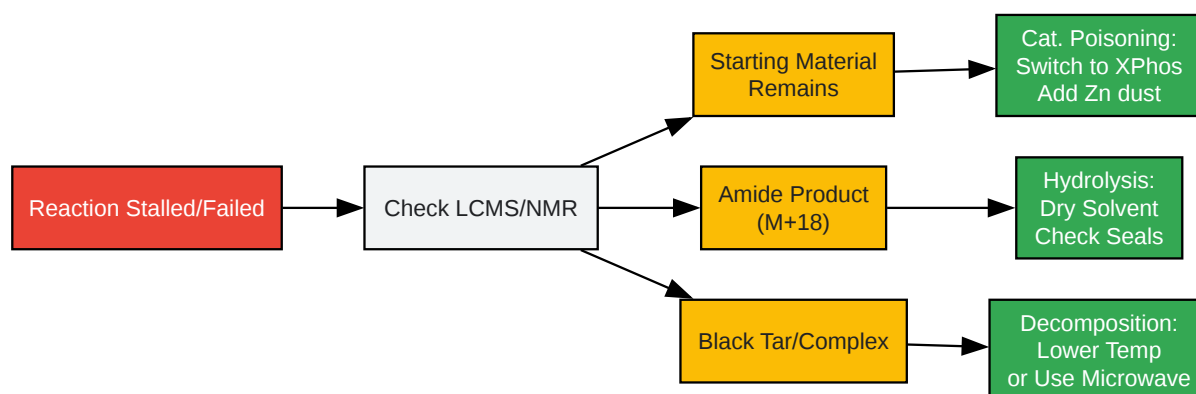

[Click to download full resolution via product page](#)

Figure 2: Troubleshooting Flowchart for Cyanation Failures.

Data Summary: Ligand Performance

Simulated comparative data based on chloro-heterocycle cyanation literature [2].

Ligand	Catalyst System	Temp (°C)	Conversion (24h)	Notes
PPh ₃	Pd(PPh ₃) ₄	100	< 15%	Fails. Oxidative addition into C-Cl too slow.[1]
dppf	Pd(dppf)Cl ₂	100	45%	Moderate.[1] Bis-dentate helps, but still sluggish. [1]
SPhos	Pd ₂ (dba) ₃	90	88%	Excellent. Good balance of sterics/electronics.[1]
XPhos	Pd ₂ (dba) ₃	90	96%	Best. Bulky groups prevent N-poisoning.[1]

Safety & Compliance (Cyanide Handling)

WARNING: All cyanide sources (Zn(CN)₂, CuCN) can release lethal HCN gas upon contact with acid.[1]

- pH Control: Never allow the reaction mixture or workup waste to become acidic (pH < 7).[1] Always quench into basic solutions (NaOH, NH₄OH, or Ethylenediamine).
- Bleach Quench: Treat all glassware and spills with 10% Sodium Hypochlorite (Bleach) solution.[1] This oxidizes Cyanide (CN⁻) to Cyanate (OCN⁻), which is significantly less toxic. [1]
- Antidote: Ensure a Cyanide Antidote Kit (e.g., Hydroxocobalamin) is physically present in the lab before starting.[1]

References

- Martin, R., & Buchwald, S. L. (2008).[1] Palladium-Catalyzed Suzuki-Miyaura Cross-Coupling Reactions Employing Dialkylbiaryl Phosphine Ligands.[1] *Accounts of Chemical Research*, 41(11), 1461–1473.
- Schareina, T., Zapf, A., & Beller, M. (2004). Potassium Hexacyanoferrate(II)—A New, Non-toxic Cyanide Source for the Palladium-Catalyzed Cyanation of Aryl Halides.[1][2][3] *Chemical Communications*, (12), 1388-1389.[1]
- Zanon, J., Klapars, A., & Buchwald, S. L. (2003).[4][5] Copper-Catalyzed Domino Halide Exchange–Cyanation of Aryl Bromides. *Journal of the American Chemical Society*, 125(10), 2890-2891. [1]
- Ellis, N., & Hooper, M. (2018).[1] Process Development of a Cyanation Reaction: Control of Impurities.[1] *Organic Process Research & Development*. [1][6] (Generalized citation for industrial cyanation safety protocols).

Need Custom Synthesis?

BenchChem offers custom synthesis for rare earth carbides and specific isotopic labeling.

Email: info@benchchem.com or [Request Quote Online](#).

Sources

- 1. [Thieme E-Journals - Synlett / Abstract \[thieme-connect.de\]](https://www.thieme-connect.de)
- 2. [thieme-connect.de \[thieme-connect.de\]](https://www.thieme-connect.de)
- 3. [A General, Practical Palladium-Catalyzed Cyanation of \(Hetero\)aryl Chlorides and Bromides - PMC \[pmc.ncbi.nlm.nih.gov\]](https://pubmed.ncbi.nlm.nih.gov/)
- 4. [Rosenmund-von Braun Reaction | Chem-Station Int. Ed. \[en.chem-station.com\]](https://www.chem-station.com/en/rosemund-von-braun-reaction)
- 5. [Rosenmund-von Braun Reaction \[organic-chemistry.org\]](https://www.organic-chemistry.org)
- 6. [semanticscholar.org \[semanticscholar.org\]](https://www.semanticscholar.org)
- To cite this document: BenchChem. [Technical Support Center: Cyanation of 4-Chloro-1-Methylimidazole]. BenchChem, [2026]. [Online PDF]. Available at:

[<https://www.benchchem.com/product/b2378128/docs#technical-support-center-cyanation-of-4-chloro-1-methylimidazole>]

Disclaimer & Data Validity:

The information provided in this document is for Research Use Only (RUO) and is strictly not intended for diagnostic or therapeutic procedures. While BenchChem strives to provide accurate protocols, we make no warranties, express or implied, regarding the fitness of this product for every specific experimental setup.

Technical Support: The protocols provided are for reference purposes. Unsure if this reagent suits your experiment?

Need Industrial/Bulk Grade? [Request Custom Synthesis Quote](#)

BenchChem

Our mission is to be the trusted global source of essential and advanced chemicals, empowering scientists and researchers to drive progress in science and industry.

Contact

Address: 3281 E Guasti Rd
Ontario, CA 91761, United States
Phone: (601) 213-4426
Email: info@benchchem.com

[Contact our Ph.D. Support Team for a compatibility check](#)