

Structure-activity relationship (SAR) studies of ... derivatives.

Author: BenchChem Technical Support Team. **Date:** April 2026

Compound of Interest

Compound Name: *3-(naphthalen-2-yl)-1H-1,2,4-triazol-5-amine*

CAS No.: 502686-00-2

Cat. No.: B2375180

[Get Quote](#)

The development of Epidermal Growth Factor Receptor (EGFR) tyrosine kinase inhibitors (TKIs) stands as a cornerstone of precision oncology, particularly for Non-Small Cell Lung Cancer (NSCLC). Among the various chemical scaffolds explored, quinazoline derivatives have proven exceptionally successful, yielding multiple generations of clinically approved drugs.

This guide provides an in-depth Structure-Activity Relationship (SAR) analysis of quinazoline-based EGFR inhibitors, objectively comparing their biochemical performance against wild-type and mutant variants, and detailing the experimental workflows required to validate these compounds.

Mechanistic Context: EGFR Signaling and Inhibition

EGFR is a transmembrane glycoprotein. Upon ligand binding, it undergoes dimerization and autophosphorylation, triggering downstream signaling cascades (Ras/Raf/MEK/ERK and PI3K/AKT) that drive cell proliferation. Quinazoline derivatives act as ATP-competitive inhibitors, lodging into the kinase domain's ATP-binding cleft to halt this phosphorylation cascade [1](#).

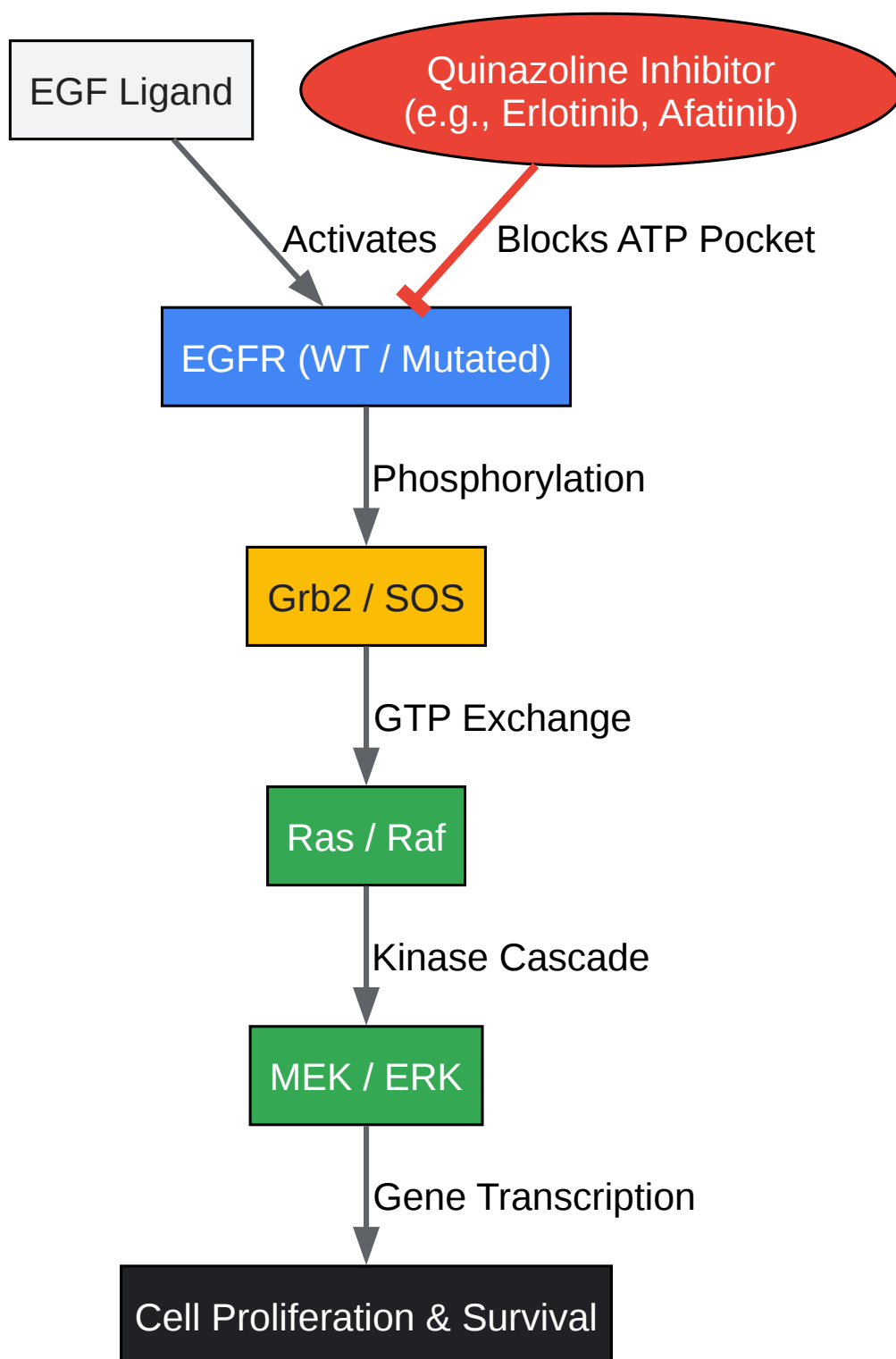

[Click to download full resolution via product page](#)

Fig 1. EGFR signaling cascade and inhibitory mechanism of quinazoline derivatives.

Structure-Activity Relationship (SAR) of the Quinazoline Scaffold

The pharmacological success of quinazoline derivatives stems from their highly tunable 4-anilinoquinazoline core. SAR studies have established several critical design rules for optimizing target affinity and overcoming resistance mechanisms [1](#):

- **The Quinazoline Core (Hinge Binding):** The N1 atom of the quinazoline ring is strictly required. It acts as a hydrogen bond acceptor, interacting directly with the backbone NH of Met793 in the hinge region of the EGFR kinase domain.
- **C4 Aniline Substitutions (Hydrophobic Pocket):** The aniline ring at the C4 position projects deep into a hydrophobic pocket. Substitutions at the meta and ortho positions are highly favored over para substitutions. For example, the 3-ethynyl group in Erlotinib and the 3-chloro-4-fluoro group in Gefitinib maximize van der Waals interactions within this cleft.
- **C6 and C7 Substitutions (Solvent Interface):** The C6 and C7 positions are oriented toward the solvent-exposed opening of the ATP cleft. Appending bulky, water-soluble functional groups here (such as the morpholine ring in Gefitinib or the methoxyethoxy groups in Erlotinib) drastically improves the drug's pharmacokinetic profile (solubility and bioavailability) without causing steric clashes with the receptor.
- **C6 Michael Acceptors (Covalent Binding):** The emergence of the T790M "gatekeeper" mutation increases the receptor's affinity for ATP and introduces steric bulk, rendering first-generation reversible inhibitors ineffective. Second-generation quinazolines (e.g., Afatinib) overcome this by incorporating an acrylamide group (a Michael acceptor) at the C6 position. This enables the formation of an irreversible covalent bond with the Cys797 residue, permanently inactivating the enzyme.

Comparative Performance Data

To objectively evaluate the efficacy of these structural modifications, we must compare their half-maximal inhibitory concentrations (IC₅₀) across Wild-Type (WT) EGFR and clinically relevant mutants (Exon 19 deletion, L858R, and the T790M resistance mutation).

Note: Osimertinib, a mono-anilino-pyrimidine, is included below as the modern clinical benchmark for T790M-selective inhibition.

Inhibitor Class	Compound	EGFR WT IC50 (nM)	Exon 19 Del (PC-9) IC50 (nM)	L858R/T790M (H1975) IC50 (nM)	Binding Mode
1st Gen Quinazoline	Gefitinib	~15	7	>10,000 (Resistant)	Reversible
1st Gen Quinazoline	Erlotinib	~20	7	>10,000 (Resistant)	Reversible
2nd Gen Quinazoline	Afatinib	~0.5	0.8	57	Irreversible (Covalent)
3rd Gen Pyrimidine	Osimertinib	493.8	13	5 - 11.4	Irreversible (Mutant-Selective)

Data synthesized from comparative in vitro modeling studies [2](#), [3](#).

Analysis: While Afatinib (2nd Gen) successfully inhibits the T790M mutant biochemically, its high potency against WT EGFR leads to severe dose-limiting toxicities (e.g., severe rash, diarrhea) in the clinic. This highlights the necessity of the structural shift toward the pyrimidine scaffold seen in Osimertinib, which spares WT EGFR while maintaining sub-nanomolar potency against T790M.

Experimental Validation Workflows

Evaluating novel quinazoline derivatives requires a self-validating, orthogonal testing approach. Biochemical assays confirm direct target engagement, while cellular assays validate membrane permeability and functional efficacy.

Protocol 1: Biochemical Profiling via ADP-Glo™ Kinase Assay

The ADP-Glo™ assay is a luminescent method that measures ADP formed from a kinase reaction. Causality: By directly quantifying ADP production rather than tracking radioactive ATP, this assay provides a safer, high-throughput method. The two-step reagent addition ensures a self-validating system: it first eliminates background noise by depleting unreacted ATP, then converts ADP to ATP to generate a stable, high-contrast luminescent signal [4](#).

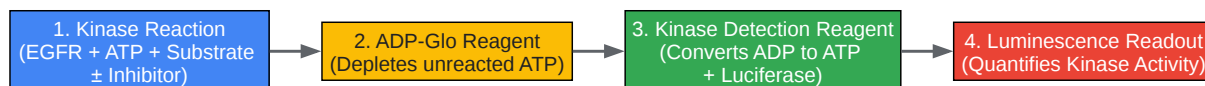

[Click to download full resolution via product page](#)

Fig 2. Step-by-step workflow of the ADP-Glo Kinase Assay for evaluating EGFR inhibitors.

Step-by-Step Methodology:

- Preparation: Prepare 1X Tyrosine Kinase Buffer (40mM Tris pH 7.5, 20mM MgCl₂, 0.1mg/ml BSA, 2mM MnCl₂, 50μM DTT).
- Compound Plating: Add 1 μL of the quinazoline derivative (in a 10-point, 3-fold serial dilution) or 5% DMSO (vehicle control) to a 384-well low-volume plate. Causality: Serial dilutions allow for the generation of a precise dose-response curve to calculate IC₅₀. The DMSO control establishes the 100% uninhibited kinase activity baseline.
- Enzyme Addition: Add 2 μL of purified EGFR enzyme (WT or specific mutant). Incubate for 15 minutes at room temperature. Causality: Pre-incubation is critical for covalent inhibitors (like Afatinib) to allow time for the irreversible bond to form before ATP competition begins.
- Reaction Initiation: Add 2 μL of the ATP/Substrate mix to initiate the reaction. Incubate at room temperature for 60 minutes.
- ATP Depletion: Add 5 μL of ADP-Glo™ Reagent. Incubate for 40 minutes. Causality: This terminates the kinase reaction and degrades all remaining unconsumed ATP, effectively dropping the assay background to near-zero.

- Detection: Add 10 μ L of Kinase Detection Reagent. Incubate for 30 minutes. This converts the generated ADP back into ATP, driving a luciferase/luciferin reaction.
- Readout & Validation: Record luminescence (0.5-1 second integration). Calculate the Z'-factor using positive (no enzyme) and negative (DMSO) controls. Validation Rule: A Z'-factor > 0.5 confirms the assay is robust and the generated IC50 values are trustworthy.

Protocol 2: Cellular Viability Validation (MTS Assay)

Biochemical potency does not always translate to cellular efficacy due to poor membrane permeability or high efflux ratios. The MTS assay validates functional target engagement in living cells.

Step-by-Step Methodology:

- Cell Seeding: Seed human NSCLC cell lines dependent on specific EGFR mutations (e.g., PC-9 for Exon 19 deletion; H1975 for L858R/T790M) at 3,000 cells/well in a 96-well plate. Allow 24 hours for attachment.
- Drug Treatment: Treat cells with serial dilutions of the quinazoline derivatives (0.1 nM to 10 μ M) and incubate for 72 hours at 37°C, 5% CO₂.
- MTS Addition: Add 20 μ L of MTS reagent per well. Causality: MTS is a tetrazolium compound that is bioreduced by the NAD(P)H-dependent dehydrogenase enzymes of metabolically active cells into a colored formazan product. This directly links metabolic activity to cell viability, validating that EGFR inhibition is successfully inducing cell cycle arrest or apoptosis.
- Readout: Incubate for 1-4 hours, then measure absorbance at 490 nm using a microplate reader. Plot absorbance against the log of compound concentration to derive the cellular IC50.

References

- Medicinal Chemistry of Quinazolines as Anticancer Agents Targeting Tyrosine Kinases. MDPI. Available at:[\[Link\]](#)

- In vitro modeling to determine mutation specificity of EGFR tyrosine kinase inhibitors against clinically relevant EGFR mutants in non-small-cell lung cancer. Oncotarget. Available at: [\[Link\]](#)
- Osimertinib making a breakthrough in lung cancer targeted therapy. NIH / PMC. Available at: [\[Link\]](#)
- EGFR Kinase Assay - Promega Corporation. Promega. Available at: [\[Link\]](#)

Need Custom Synthesis?

BenchChem offers custom synthesis for rare earth carbides and specific isotopic labeling.

Email: info@benchchem.com or [Request Quote Online](#).

Sources

- [1. mdpi.com \[mdpi.com\]](#)
- [2. In vitro modeling to determine mutation specificity of EGFR tyrosine kinase inhibitors against clinically relevant EGFR mutants in non-small-cell lung... | Oncotarget \[oncotarget.com\]](#)
- [3. Osimertinib making a breakthrough in lung cancer targeted therapy - PMC \[pmc.ncbi.nlm.nih.gov\]](#)
- [4. promega.com.cn \[promega.com.cn\]](#)
- To cite this document: BenchChem. [Structure-activity relationship (SAR) studies of ... derivatives.]. BenchChem, [2026]. [Online PDF]. Available at: [\[https://www.benchchem.com/product/b2375180/docs#structure-activity-relationship-sar-studies-of-derivatives\]](https://www.benchchem.com/product/b2375180/docs#structure-activity-relationship-sar-studies-of-derivatives)

Disclaimer & Data Validity:

The information provided in this document is for Research Use Only (RUO) and is strictly not intended for diagnostic or therapeutic procedures. While BenchChem strives to provide accurate protocols, we make no warranties, express or implied, regarding the fitness of this product for every specific experimental setup.

Technical Support: The protocols provided are for reference purposes. Unsure if this reagent suits your experiment?

Need Industrial/Bulk Grade? [Request Custom Synthesis Quote](#)

BenchChem

Our mission is to be the trusted global source of essential and advanced chemicals, empowering scientists and researchers to drive progress in science and industry.

Contact

Address: 3281 E Guasti Rd
Ontario, CA 91761, United States
Phone: (601) 213-4426
Email: info@benchchem.com

[Contact our Ph.D. Support Team for a compatibility check](#)