

Structural analysis of 5-chloropyrimidine derivatives containing bromophenoxy groups

Author: BenchChem Technical Support Team. **Date:** April 2026

Compound of Interest

Compound Name: 2-(4-Bromophenoxy)-5-chloropyrimidine

CAS No.: 1538671-54-3

Cat. No.: B2375608

[Get Quote](#)

Structural Analysis & Synthetic Logic of 5-Chloropyrimidine Bromophenoxy Ethers

Executive Summary

The 5-chloropyrimidine scaffold, particularly when functionalized with bromophenoxy moieties, represents a "privileged structure" in modern medicinal chemistry. This specific architecture is central to the design of non-nucleoside reverse transcriptase inhibitors (NNRTIs), kinase inhibitors, and antimicrobial agents.

The structural synergy arises from two key factors:

- **Electronic Modulation:** The C5-chlorine atom exerts a strong electron-withdrawing effect (), lowering the of the pyrimidine nitrogens and activating the C2/C4 positions for nucleophilic attack.

- Halogen Bonding: The bromophenoxy group introduces a polarizable bromine atom capable of forming directed halogen bonds (

-hole interactions) with backbone carbonyls in protein active sites, significantly enhancing binding affinity compared to non-halogenated analogs.

This guide details the synthetic regioselectivity, crystallographic features, and spectroscopic validation of these derivatives.

Synthetic Architecture: Regioselectivity in

The synthesis of 5-chloropyrimidine ethers relies on Nucleophilic Aromatic Substitution (

). When starting from 2,4,5-trichloropyrimidine, the reaction with a phenol (e.g., 4-bromophenol) presents a regioselectivity challenge between the C2 and C4 positions.

The C4-Selectivity Rule

Under standard basic conditions (

, DMF/MeCN), substitution occurs preferentially at the C4 position.

- Mechanism: The intermediate Meisenheimer complex at C4 is energetically favored due to the ability of the N3 nitrogen to stabilize the negative charge more effectively than at C2.
- Steric Influence: While the C5-Cl adds steric bulk, the C4 position remains more accessible than C2, which is flanked by two ring nitrogens.
- Temperature Control: Lower temperatures (

to RT) favor the kinetic C4 product. Higher temperatures may lead to bis-substitution (C2 and C4).

Synthetic Workflow Diagram

The following diagram illustrates the reaction pathway and the branching logic for regiocontrol.

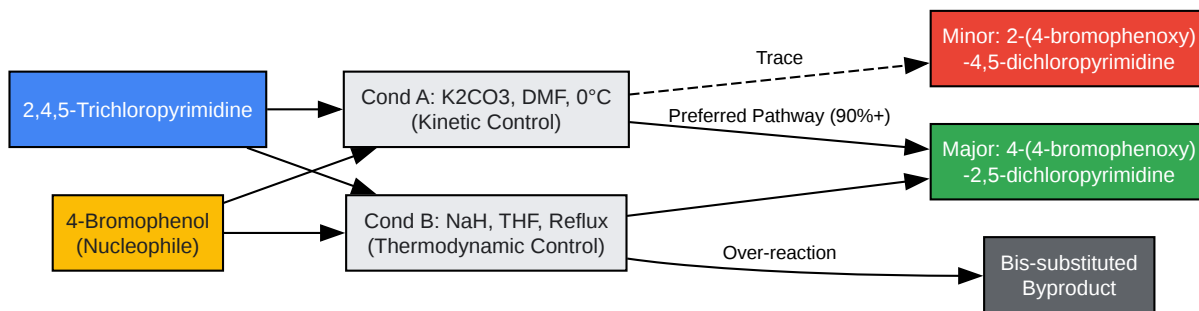

[Click to download full resolution via product page](#)

Figure 1: Regioselective pathways for the mono-substitution of 2,4,5-trichloropyrimidine.

Structural Characterization & Halogen Bonding

Once synthesized, the characterization of 5-chloropyrimidine bromophenoxy derivatives requires a focus on the specific non-covalent interactions that define their biological activity.

Crystallographic Analysis (X-Ray)

In the solid state, these molecules often adopt a "butterfly" or "propeller" conformation (similar to DAPY inhibitors like Etravirine). This flexibility allows the molecule to adjust to the "breathing" motions of a target enzyme's binding pocket.

The Halogen Bond (

-hole):

- Bromine (Phenoxy): The Br atom exhibits a positive electrostatic potential cap (

-hole) along the C-Br bond axis. In crystal structures, look for

or

distances less than the sum of the van der Waals radii (approx. 3.4 Å). This is a directional interaction (bond angle

).

- Chlorine (C5): The C5-Cl is less polarizable than Br but contributes to lipophilicity and fills hydrophobic pockets. It rarely acts as a strong halogen bond donor in the presence of bromine.

NMR Spectroscopy Validation

The 5-Cl substituent causes distinct shifts in the

NMR spectrum compared to a non-chlorinated pyrimidine.

Carbon Position	Approx. Shift (ppm)	Structural Cause
C2	158 - 160	Flanked by two nitrogens; deshielded.
C4	162 - 165	Ipsso-carbon attached to oxygen; strongly deshielded.
C5	115 - 120	Diagnostic Peak. Upfield shift due to shielding/resonance relative to C4/C6, but inductive effect of Cl stabilizes it.
C6	155 - 158	Adjacent to N1; typical pyrimidine CH.

Computational Analysis (Docking & DFT)

To validate the structural hypothesis before synthesis, computational modeling is essential.

Molecular Electrostatic Potential (MEP)

Density Functional Theory (DFT) calculations (e.g., B3LYP/6-31G*) will visualize the electron density.

- Observation: You will observe a region of high electron density (red) over the pyrimidine nitrogens and the phenoxy oxygen.

- Critical Feature: A distinct region of electron deficiency (blue) will appear at the tip of the Bromine atom. This validates the potential for halogen bonding.[10]

SAR Logic Diagram

The following diagram details the Structure-Activity Relationship (SAR) logic derived from the structural analysis.

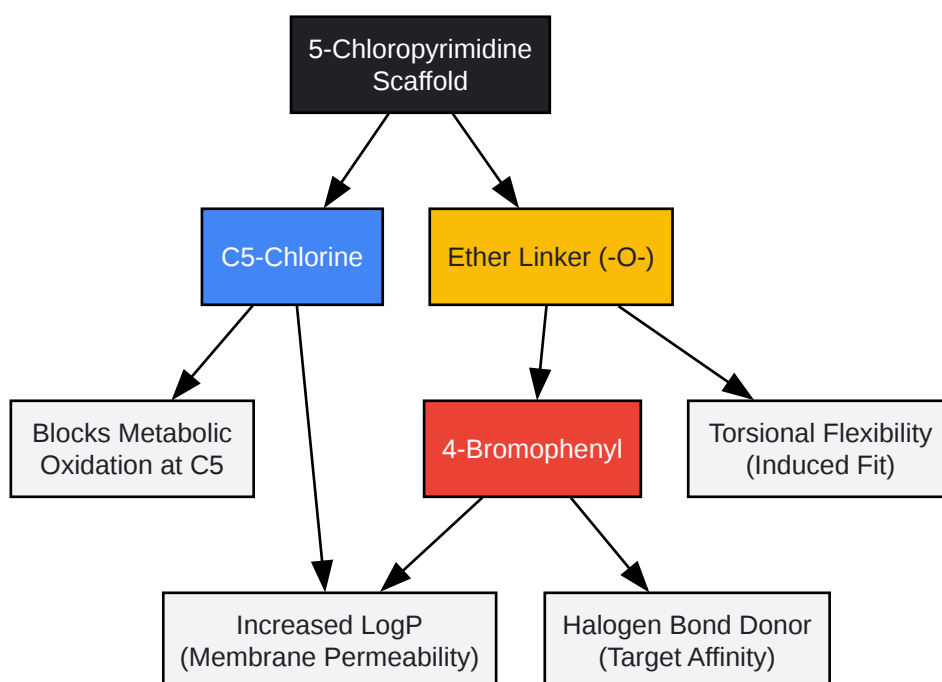

[Click to download full resolution via product page](#)

Figure 2: Structure-Activity Relationship (SAR) map of the 5-chloropyrimidine-bromophenoxy pharmacophore.

Experimental Protocol: Synthesis of 4-(4-bromophenoxy)-2,5-dichloropyrimidine

Objective: Selective mono-substitution of 2,4,5-trichloropyrimidine at the C4 position.

Materials

- 2,4,5-Trichloropyrimidine (1.0 eq)[1]

- 4-Bromophenol (1.05 eq)
- Potassium Carbonate (, anhydrous, 1.5 eq)
- DMF (Dimethylformamide, anhydrous) or Acetonitrile

Step-by-Step Methodology

- Preparation: In a round-bottom flask equipped with a magnetic stir bar, dissolve 4-bromophenol (1.05 eq) in anhydrous DMF (5 mL per mmol).
- Activation: Add (1.5 eq). Stir at room temperature for 15 minutes to generate the phenoxide anion. Note: The solution may change color slightly.
- Addition: Cool the mixture to using an ice bath. Add 2,4,5-trichloropyrimidine (1.0 eq) dropwise (if liquid) or portion-wise (if solid).
- Reaction: Allow the reaction to warm to room temperature naturally. Stir for 4–6 hours.
 - Monitoring: Check reaction progress via TLC (Hexane:Ethyl Acetate 4:1). The starting material (trichloropyrimidine) is less polar and will move faster than the mono-substituted product.
- Workup:
 - Pour the reaction mixture into ice-cold water (10x volume).
 - A white precipitate should form. Stir for 30 minutes to ensure full precipitation.
 - Filter the solid. Wash with water () to remove residual DMF and base.

- Purification: Recrystallize from Ethanol or perform flash column chromatography (Silica gel, 0-10% EtOAc in Hexanes) if high purity is required for X-ray analysis.

Self-Validating Checkpoint:

- Mass Spectrometry: The product should show a distinct isotope pattern due to Cl and Br. Look for the M+2 and M+4 peaks characteristic of a system.
- Regiochemistry Check: If the melting point is significantly lower than expected or the NMR shows complex splitting, you may have a mixture of C2/C4 isomers.

References

- American Chemical Society (ACS). (2012).^[3] The Discovery of N-[5-(4-Bromophenyl)-6-[2-[(5-bromo-2-pyrimidinyl)oxy]ethoxy]... Journal of Medicinal Chemistry. Retrieved from [[Link](#)]
- National Institutes of Health (NIH). (2021). Halogen and Hydrogen Bond Motifs in Ionic Cocrystals Derived from 3-Halopyridinium Halogenides. Retrieved from [[Link](#)]
- MDPI. (2021). Assessment of the Antimicrobial and Antiproliferative Activities of Chloropyrazine-Tethered Pyrimidine Derivatives. Retrieved from [[Link](#)]

Need Custom Synthesis?

BenchChem offers custom synthesis for rare earth carbides and specific isotopic labeling.

Email: info@benchchem.com or [Request Quote Online](#).

Sources

- 1. pdf.benchchem.com [pdf.benchchem.com]
- 2. Understanding the highly variable Regioselectivity in SNAr reaction of Dichloropyrimidines - RCS Research Chemistry Services [rcs.wuxiapptec.com]
- 3. pubs.acs.org [pubs.acs.org]

- [4. Regioselective Control of the S_NAr Amination of 5-Substituted-2,4-Dichloropyrimidines Using Tertiary Amine Nucleophiles - PubMed \[pubmed.ncbi.nlm.nih.gov\]](#)
- [5. ijppr.humanjournals.com \[ijppr.humanjournals.com\]](#)
- [6. pubs.acs.org \[pubs.acs.org\]](#)
- [7. researchgate.net \[researchgate.net\]](#)
- [8. researchgate.net \[researchgate.net\]](#)
- [9. mdpi.com \[mdpi.com\]](#)
- [10. Halogen and Hydrogen Bond Motifs in Ionic Cocrystals Derived from 3-Halopyridinium Halogenides and Perfluorinated Iodobenzenes - PMC \[pmc.ncbi.nlm.nih.gov\]](#)
- To cite this document: BenchChem. [Structural analysis of 5-chloropyrimidine derivatives containing bromophenoxy groups]. BenchChem, [2026]. [Online PDF]. Available at: [\[https://www.benchchem.com/product/b2375608/docs#structural-analysis-of-5-chloropyrimidine-derivatives-containing-bromophenoxy-groups\]](https://www.benchchem.com/product/b2375608/docs#structural-analysis-of-5-chloropyrimidine-derivatives-containing-bromophenoxy-groups)

Disclaimer & Data Validity:

The information provided in this document is for Research Use Only (RUO) and is strictly not intended for diagnostic or therapeutic procedures. While BenchChem strives to provide accurate protocols, we make no warranties, express or implied, regarding the fitness of this product for every specific experimental setup.

Technical Support: The protocols provided are for reference purposes. Unsure if this reagent suits your experiment?

Need Industrial/Bulk Grade? [Request Custom Synthesis Quote](#)

BenchChem

Our mission is to be the trusted global source of essential and advanced chemicals, empowering scientists and researchers to drive progress in science and industry.

Contact

Address: 3281 E Guasti Rd
Ontario, CA 91761, United States
Phone: (601) 213-4426
Email: info@benchchem.com

Contact our Ph.D. Support Team for a compatibility check