

# Comparative Guide: Mass Spectrometry Fragmentation of Benzyl-Substituted Aminopyrazoles

**Author:** BenchChem Technical Support Team. **Date:** April 2026

## Compound of Interest

Compound Name:	1-(4-methylbenzyl)-1H-pyrazol-4-amine
CAS No.:	1002414-59-6; 1189462-86-9
Cat. No.:	B2374744

[Get Quote](#)

## Executive Summary

Benzyl-substituted aminopyrazoles are critical scaffolds in kinase inhibitor development (e.g., substituted pyrazolo[1,5-a]pyrimidines). However, their structural analysis is complicated by annular tautomerism and regioisomerism (N1 vs. N2 alkylation) during synthesis.

This guide provides a comparative analysis of the mass spectrometry (MS) behaviors of N-benzyl aminopyrazoles versus their N-phenyl and N-alkyl analogs. We focus on differentiating regioisomers using Electrospray Ionization (ESI-MS/MS) and Electron Ionization (EI), highlighting the diagnostic tropylium ion (

91) and ortho-effect rearrangements.

## Key Findings

- Diagnostic Marker: The formation of the tropylium ion (

91) is the definitive fingerprint for benzyl-substituted pyrazoles, distinguishing them from phenyl analogs (

77).

- Regioisomer Differentiation: N1-benzyl-5-aminopyrazoles (adjacent substituents) exhibit distinct fragmentation kinetics compared to N1-benzyl-3-aminopyrazoles due to steric-assisted bond cleavage.
- Ionization Mode: ESI-MS/MS is superior for analyzing intact protonated precursors ( ), while EI provides structurally rich fragmentation maps dominated by benzylic cleavage.

## The Analytical Challenge: Regioisomerism

In drug development, reacting hydrazines with

-ketonitriles yields two possible aminopyrazole isomers. Distinguishing these is critical for Structure-Activity Relationship (SAR) studies.

Feature	Isomer A: 5-Amino-1-benzylpyrazole	Isomer B: 3-Amino-1-benzylpyrazole
Structure	Amino ( ) and Benzyl ( ) are adjacent (positions 5 and 1).	Amino and Benzyl are separated by a CH group (positions 3 and 1).
Sterics	High steric strain between and .	Low steric strain.
MS Behavior	Facile loss of benzyl group due to steric relief; "Ortho-effect" interactions.	Standard benzylic cleavage; higher stability of precursor ion.

## Comparative Fragmentation Analysis

## Scenario A: Benzyl vs. Phenyl Substitution

The most common SAR modification is swapping a flexible benzyl group for a rigid phenyl ring.

- Benzyl-Aminopyrazoles:
  - Mechanism: Benzylic C-N bond cleavage is energetically favorable.
  - Signature Ion:  
91 (Tropylium cation,  
).
  - Secondary Fragment: Loss of HCN from the pyrazole ring after benzyl loss.
- Phenyl-Aminopyrazoles:
  - Mechanism: The N-Phenyl bond ( ) is stronger and harder to cleave.
  - Signature Ion:  
77 (Phenyl cation,  
).[1]
  - Behavior: Often retains the phenyl ring and fragments via ring opening of the pyrazole core first.

## Scenario B: ESI (Soft) vs. EI (Hard) Ionization[2]

Parameter	Electrospray Ionization (ESI)	Electron Ionization (EI)
Primary Ion	(Protonated Molecule)	(Molecular Radical Cation)
Energy Regime	Low internal energy (Soft)	High energy (70 eV)
Key Pathway	Charge-remote fragmentation; Proton transfer driven.	Radical-site initiated cleavage.
Dominant Peak	Intact Parent (requires MS/MS to fragment).	91 (Base peak for benzyl derivatives).
Utility	Best for LC-MS quantification and PK studies.	Best for library matching and structural confirmation.

## Mechanistic Deep Dive

The fragmentation of N-benzyl aminopyrazoles is driven by the stability of the tropylium ion. Upon collisional activation (CID), the protonated precursor undergoes heterolytic cleavage.

### Pathway: Tropylium Formation

The benzylic carbon-nitrogen bond cleaves. The resulting benzyl cation rearranges to the seven-membered tropylium ring, which is aromatic and highly stable.

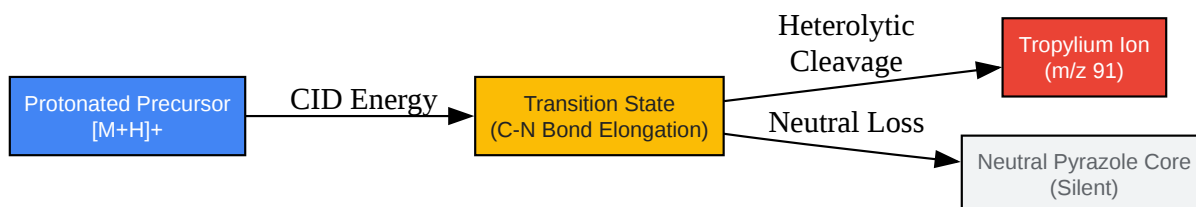

[Click to download full resolution via product page](#)

Figure 1: Formation of the diagnostic Tropylium ion (

91) from N-benzyl aminopyrazoles.

## The "Ortho-Effect" in 5-Aminopyrazoles

In the 5-amino-1-benzyl isomer, the amino group protons can interact with the benzyl ring

-system or the benzylic carbon. This often leads to:

- Enhanced loss of

: The benzyl group can act as a proton shuttle.

- Ratio Variation: The ratio of

to

is often higher in the 5-amino isomer compared to the 3-amino isomer due to steric relief driving the benzyl loss.

## Experimental Protocol: Regioisomer Differentiation

Objective: To distinguish N1-benzyl-5-aminopyrazole from N1-benzyl-3-aminopyrazole using ESI-MS/MS.

### Materials

- LC System: UHPLC (e.g., Agilent 1290 or Waters Acquity).
- MS System: Q-TOF or Triple Quadrupole (e.g., Sciex 6500+).
- Solvents: LC-MS grade Acetonitrile and Water + 0.1% Formic Acid.

### Workflow Diagram

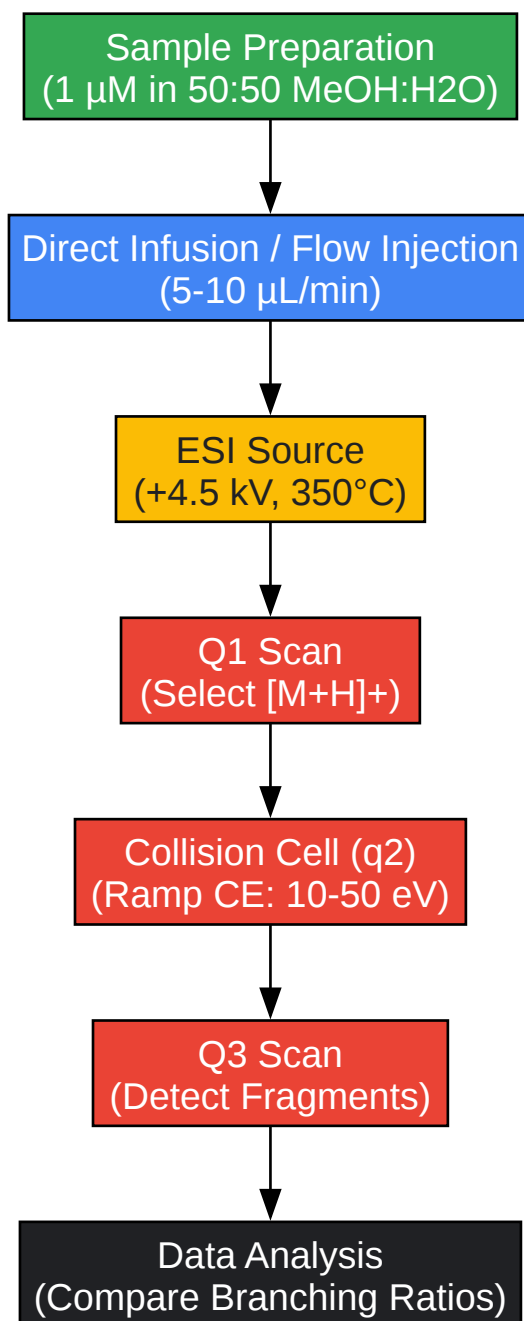

[Click to download full resolution via product page](#)

Figure 2: Step-by-step experimental workflow for ESI-MS/MS characterization.[2]

## Step-by-Step Methodology

- Sample Preparation: Dissolve 1 mg of the compound in 1 mL of Methanol. Dilute to 1 μM in 50:50 Acetonitrile:Water (+0.1% Formic Acid).

- Source Optimization: Tune the ESI source to maximize the intensity of the parent ion
  - . Avoid in-source fragmentation by keeping the declustering potential (DP) moderate (e.g., 60-80 V).
- Energy Ramping: Perform a "Breakdown Curve" experiment. Select the precursor ion in Q1 and ramp the Collision Energy (CE) from 10 eV to 60 eV in 5 eV increments.
- Data Collection: Monitor the intensity of:
  - Parent Ion
  - Tropylium Ion (91)
  - Pyrazole Core Ion ( )
- Analysis: Plot the Relative Abundance vs. CE. The isomer with the sterically crowded benzyl group (5-amino) typically fragments at lower collision energies (lower ) than the sterically unhindered isomer (3-amino).

## Data Summary: Diagnostic Ions

The following table summarizes the theoretical and observed

values for a generic N-benzyl-aminopyrazole (

Da).

Fragment Ion Identity	m/z (approx)	Origin	Diagnostic Value
Protonated Molecule	174		Precursor for MS/MS.
Tropylium Cation	91		High. Confirms Benzyl group. Base peak in EI; major fragment in ESI.
Phenyl Cation	77		High. Absence of this (relative to 91) rules out N-phenyl analogs.
Pyrazole Core	84		Medium. Represents the aminopyrazole ring after benzyl loss.
Ring Contraction	147		Low. Common to many nitrogen heterocycles.
Ammonia Loss	157		High. Ratio of 157/91 helps distinguish 3-amino vs 5-amino isomers.

## References

- Differentiation of Heterocyclic Regioisomers. Study on N-acridin-4-ylbenzylamide vs 2-yl isomers using ESI-MS/MS, establishing the principles of "ortho-effect" in benzyl-substituted heterocycles. Journal of Mass Spectrometry. [\[Link\]](#)
- Fragmentation Mechanisms of Protonated Benzylamines. Detailed kinetic analysis of benzyl cleavage and tropylium formation in ESI-MS. Rapid Communications in Mass Spectrometry. [\[Link\]](#)
- Investigations of the Fragmentation Pathways of Benzylpyridinium Ions. Mechanistic validation of rearrangement processes leading to substituted tropylium ions under soft

ionization. Journal of Mass Spectrometry. [[Link](#)][3]

- Mass Spectrometry Fragmentation Patterns of Nitrogen Heterocycles. General guide to pyrazole and imidazole fragmentation. Chemistry LibreTexts / ChemGuide. [[Link](#)]

#### Need Custom Synthesis?

BenchChem offers custom synthesis for rare earth carbides and specific isotopic labeling.

Email: [info@benchchem.com](mailto:info@benchchem.com) or [Request Quote Online](#).

## Sources

- 1. [fiveable.me](https://fiveable.me) [[fiveable.me](https://fiveable.me)]
- 2. [researchgate.net](https://researchgate.net) [[researchgate.net](https://researchgate.net)]
- 3. Investigations of the fragmentation pathways of benzylpyridinium ions under ESI/MS conditions - PubMed [[pubmed.ncbi.nlm.nih.gov](https://pubmed.ncbi.nlm.nih.gov)]
- To cite this document: BenchChem. [Comparative Guide: Mass Spectrometry Fragmentation of Benzyl-Substituted Aminopyrazoles]. BenchChem, [2026]. [Online PDF]. Available at: [<https://www.benchchem.com/product/b2374744/docs#comparative-guide-mass-spectrometry-fragmentation-of-benzyl-substituted-aminopyrazoles>]

---

### Disclaimer & Data Validity:

The information provided in this document is for Research Use Only (RUO) and is strictly not intended for diagnostic or therapeutic procedures. While BenchChem strives to provide accurate protocols, we make no warranties, express or implied, regarding the fitness of this product for every specific experimental setup.

**Technical Support:** The protocols provided are for reference purposes. Unsure if this reagent suits your experiment?

**Need Industrial/Bulk Grade?** [Request Custom Synthesis Quote](#)

# BenchChem

Our mission is to be the trusted global source of essential and advanced chemicals, empowering scientists and researchers to drive progress in science and industry.

## Contact

Address: 3281 E Guasti Rd

Ontario, CA 91761, United States

Phone: (601) 213-4426

Email: [info@benchchem.com](mailto:info@benchchem.com)

[Contact our Ph.D. Support Team for a compatibility check](#)