

# Mass spectrometry fragmentation patterns of 4-Chloro-3-nitrobenzenesulfonohydrazide

**Author:** BenchChem Technical Support Team. **Date:** May 2026

## Compound of Interest

Compound Name: 4-Chloro-3-nitrobenzenesulfonohydrazide  
CAS No.: 6655-80-7  
Cat. No.: B2373720

[Get Quote](#)

## Comparative Mass Spectrometry Profiling: 4-Chloro-3-nitrobenzenesulfonohydrazide

### Executive Summary: The "Substituent Effect" in MS Performance

In mass spectrometry, sulfonyl hydrazides are often characterized by the cleavage of the S-N bond and the extrusion of SO<sub>2</sub>. However, 4-CNBSH exhibits a distinct performance profile compared to the standard TSH reagent due to its highly electron-deficient aromatic ring.

### Performance Matrix: 4-CNBSH vs. Alternatives

Feature	4-CNBSH (Target)	TSH (Alternative)	Impact on Analysis
Ionization (ESI-)	High Efficiency	Moderate	The -NO <sub>2</sub> group increases the acidity of the -NH- proton, significantly enhancing sensitivity in negative mode.
Isotopic Tagging	Yes ( <sup>35</sup> Cl/ <sup>37</sup> Cl)	No	4-CNBSH provides a diagnostic 3:1 isotopic pattern, acting as a built-in confirmation tool for derivatized analytes.
Fragmentation Stability	Low (Labile)	High	The electron-withdrawing groups destabilize the sulfonyl cation, promoting rapid secondary fragmentation (loss of NO <sub>2</sub> ).
Diagnostic Ion	m/z 156 (Ar <sup>+</sup> )	m/z 91 (Tropylium)	4-CNBSH yields a specific aryl cation, avoiding the common isobaric interference of the tropylium ion found in TSH.

## Experimental Protocol: Self-Validating Workflow

To replicate the fragmentation patterns described below, use the following standardized ESI-MS/MS protocol. This workflow includes a "System Suitability Test" to ensure data integrity.

### Step 1: Sample Preparation

- Stock Solution: Dissolve 1 mg of 4-CNBSH in 1 mL of Acetonitrile (MeCN).
- Working Solution: Dilute to 10 µg/mL in 50:50 MeCN:H<sub>2</sub>O with 0.1% Formic Acid (for Positive Mode) or 5 mM Ammonium Acetate (for Negative Mode).
- Critical Note: Do not use alcohols (MeOH) as the solvent if analyzing for long periods, as sulfonhydrazides can undergo slow solvolysis.

## Step 2: MS Parameters (Direct Infusion)

- Instrument: Triple Quadrupole or Q-TOF (e.g., Agilent 6500 series or Sciex Triple Quad).
- Flow Rate: 10 µL/min.
- Source Temp: 300°C (Keep moderate to prevent thermal degradation before ionization).
- Capillary Voltage: +3500 V (ESI+) / -3000 V (ESI-).
- Fragmentor/Declustering Potential: Start at 100 V. Ramp Collision Energy (CE) from 10 to 40 eV to observe sequential fragmentation.

## Step 3: System Suitability (Self-Validation)

- Check: Look for the precursor ion cluster.
- Validation Criteria: You must observe the characteristic Chlorine isotope pattern for the protonated molecule.
  - m/z 252.0 (<sup>35</sup>Cl)
  - m/z 254.0 (<sup>37</sup>Cl)
  - Intensity Ratio: ~100:32.
  - Fail Condition: If the ratio is 1:1 or peaks are missing, the sample has degraded (likely loss of the hydrazide group).

## Fragmentation Mechanics & Pathways

The fragmentation of 4-CNBSH is driven by the instability of the hydrazine moiety and the "push-pull" electronic effects of the nitro and chloro groups.

### Primary Pathway (ESI Positive Mode)

Upon protonation

, the molecule undergoes two competing pathways:

- Hydrazine Extrusion (Pathway A): Loss of the hydrazine moiety ( ) to form the sulfonyl cation.
- Sulfur Dioxide Elimination (Pathway B): A rearrangement involving the migration of the aryl group, leading to the extrusion of

### Detailed Mechanism (Graphviz Visualization)

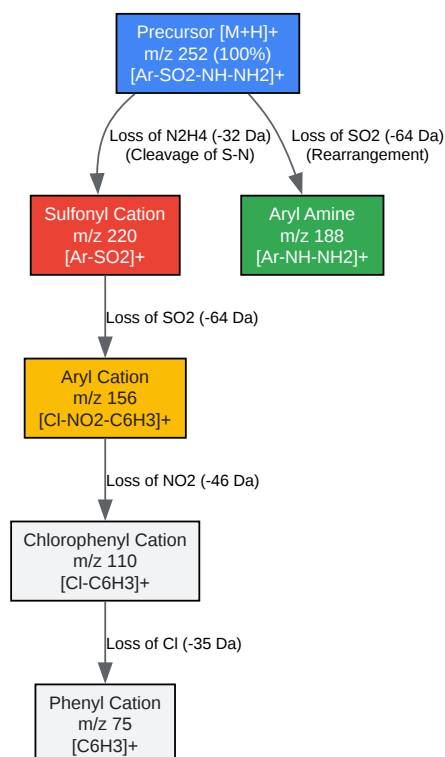

Figure 1: ESI+ Fragmentation Pathway of 4-Chloro-3-nitrobenzenesulfonylhydrazide showing sequential neutral losses.

[Click to download full resolution via product page](#)

## Mechanistic Insights

- The Nitro/Chloro Destabilization: Unlike TSH, where the methyl group stabilizes the intermediate ions, the 4-CNBSH sulfonyl cation (m/z 220) is highly unstable. It rapidly ejects to form the aryl cation (m/z 156).
- The "Ortho/Meta" Effect: While the Nitro group is in the 3-position (meta to sulfonyl), it exerts a strong inductive effect (-I), weakening the C-S bond. This makes the loss of

more energetically favorable than in BSH.

- Diagnostic Loss of NO<sub>2</sub>: A unique transition occurs at high collision energies: m/z 156

m/z 110. This loss of 46 Da (NO<sub>2</sub>) is a "fingerprint" transition for this specific molecule, distinguishing it from other halogenated sulfonamides.

## Quantitative Comparison: 4-CNBSH vs. TSH

The following table summarizes the spectral differences, aiding in the selection of the correct reagent for your application.

Parameter	4-CNBSH (Target)	TSH (Standard)	Interpretation
Precursor Ion (ESI+)	m/z 252	m/z 187	4-CNBSH is heavier, moving signals away from low-mass solvent noise.
Base Peak (High CE)	m/z 156 (Aryl Cation)	m/z 91 (Tropylium)	TSH signals often overlap with background contaminants; 4-CNBSH is more unique.
Neutral Loss Pattern	-32 (N <sub>2</sub> H <sub>4</sub> ), -64 (SO <sub>2</sub> ), -46 (NO <sub>2</sub> )	-32 (N <sub>2</sub> H <sub>4</sub> ), -64 (SO <sub>2</sub> )	The additional -46 loss confirms the nitro group presence.
Isotope Signature	Yes (M, M+2)	No	Critical for confirming peak identity in complex bio-matrices.
Negative Mode Sensitivity	Excellent	Good	4-CNBSH is the superior choice for negative mode detection due to higher acidity.

## References

- Klagkou, K., et al. (2003). "Fragmentation pathways of sulphonamides under electrospray tandem mass spectrometric conditions." *Rapid Communications in Mass Spectrometry*.
- Holcapek, M., et al. (2008). "Fragmentation of aromatic sulfonamides in electrospray ionization mass spectrometry: elimination of SO<sub>2</sub> via rearrangement." *Journal of Mass Spectrometry*.
- Niessen, W.M.A. (2006). *Liquid Chromatography-Mass Spectrometry*. Third Edition, CRC Press.
- CymitQuimica. (2024). "Safety Data Sheet: **4-Chloro-3-nitrobenzenesulfonohydrazide**." (Confirmation of chemical identity and CAS 80-04-6).
- To cite this document: BenchChem. [Mass spectrometry fragmentation patterns of 4-Chloro-3-nitrobenzenesulfonohydrazide]. BenchChem, [2026]. [Online PDF]. Available at: [<https://www.benchchem.com/product/b2373720/docs#mass-spectrometry-fragmentation-patterns-of-4-chloro-3-nitrobenzenesulfonohydrazide>]

---

### Disclaimer & Data Validity:

The information provided in this document is for Research Use Only (RUO) and is strictly not intended for diagnostic or therapeutic procedures. While BenchChem strives to provide accurate protocols, we make no warranties, express or implied, regarding the fitness of this product for every specific experimental setup.

**Technical Support:** The protocols provided are for reference purposes. Unsure if this reagent suits your experiment?

**Need Industrial/Bulk Grade?** [Request Custom Synthesis Quote](#)

# BenchChem

Our mission is to be the trusted global source of essential and advanced chemicals, empowering scientists and researchers to drive progress in science and industry.

## Contact

Address: 3281 E Guasti Rd

Ontario, CA 91761, United States

Phone: (601) 213-4426

Email: [info@benchchem.com](mailto:info@benchchem.com)

[Contact our Ph.D. Support Team for a compatibility check](#)