

Application Note: C-C Bond Formation with Electron-Deficient Benzyl Bromides

Author: BenchChem Technical Support Team. **Date:** April 2026

Compound of Interest

Compound Name: 2,4-Difluoro-5-nitrobenzyl bromide

CAS No.: 1260790-43-9

Cat. No.: B2371299

[Get Quote](#)

Executive Summary & Strategic Importance

Electron-deficient benzyl bromides (e.g., 4-nitro, 4-cyano, or polyfluorinated benzyl bromides) are high-value electrophiles in drug discovery. They serve as precursors to "privileged structures" found in bio-active molecules (e.g., antagonists, enzyme inhibitors) where the electron-withdrawing group (EWG) modulates lipophilicity and metabolic stability.

The Paradox of Reactivity: While the EWG makes the benzylic carbon highly electrophilic (accelerating

and oxidative addition), it introduces two critical failure modes:

- **Acidity:** The benzylic protons become significantly acidic (pKa can drop <20), leading to competitive elimination (formation of stilbenes) or poly-alkylation under basic conditions.
- **Radical Stability:** Electron-deficient benzyl radicals are less stable than their electron-rich counterparts, making radical initiation (SET) thermodynamically more demanding in

photoredox manifolds.

This guide details three "Generations" of coupling technologies, prioritizing Nickel-Catalyzed Reductive Coupling and Photoredox Catalysis as the most robust modern solutions.

Mechanistic Pathways & Decision Matrix

Decision Matrix: Choosing the Right Method

Constraint	Recommended Method	Why?
Target: - Bond	Ni-Reductive Coupling	Avoids organometallic reagent prep; tolerates protic functional groups.[1][2][3]
Target: Enantioselective -Alkylation	Photoredox Organocatalysis	Mild generation of radicals; high stereocontrol via amine catalysts.
Target: Biaryl (-)	Pd-Catalyzed Suzuki	Robust, but requires careful ligand choice to prevent -hydride elimination.[4]
Substrate: Highly Acidic Benzylic H	Radical/Photoredox	Neutral/mildly basic conditions prevent anionic elimination.

Visualizing the Catalytic Logic

The following diagram illustrates the divergence between the Two-Electron (Pd/Ni cross-coupling) and One-Electron (Photoredox) pathways.

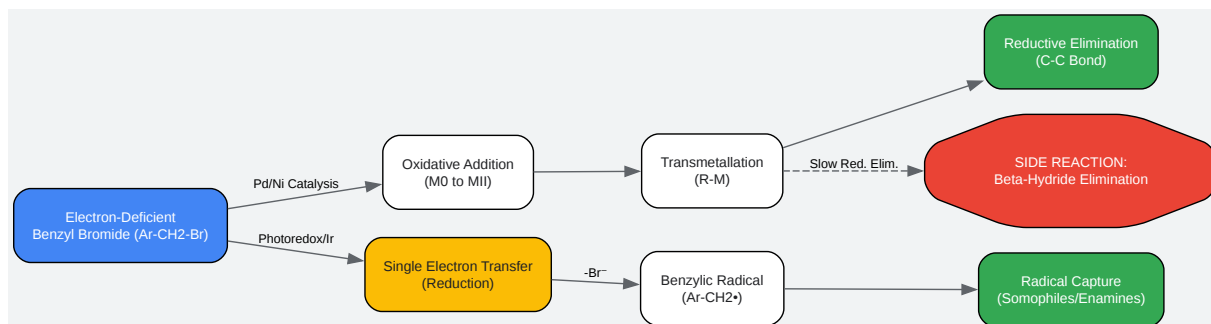

[Click to download full resolution via product page](#)

Figure 1: Mechanistic divergence. Note that electron-deficient substrates accelerate Oxidative Addition (top path) but require stronger reductants for SET (bottom path).

Protocol A: Nickel-Catalyzed Reductive Cross-Coupling

Best for: Coupling benzyl bromides with aryl iodides or vinyl bromides without pre-generating organometallics (Grignard/Zinc reagents). This "electrophile-electrophile" coupling is driven by a stoichiometric reductant (

).

The Science

Unlike Palladium, Nickel readily accesses single-electron manifolds (

), allowing it to engage alkyl halides via radical intermediates. The inclusion of Manganese (

) regenerates the active

catalyst.

- Advantage: Electron-deficient benzyl bromides are prone to anion formation. This radical mechanism avoids the formation of highly basic benzylic anions.

Materials

- Catalyst:

(Dimethoxyethane adduct)

- Ligand: 4,4'-Di-tert-butyl-2,2'-bipyridine (

)

- Reductant: Manganese powder (

, <10 micron particle size preferred)

- Additive: Sodium Iodide (

) or Tetrabutylammonium iodide (

) – Crucial for facilitating electron transfer.

- Solvent: DMA (N,N-Dimethylacetamide) – Must be anhydrous.

Step-by-Step Protocol

- Glovebox/Schlenk Setup: In a nitrogen-filled glovebox or under argon flow, charge a reaction vial with:
 - (10 mol%)
 - (10 mol%)
 - powder (2.0 equiv)
 - (0.5 equiv)
- Substrate Addition: Add the Electron-Deficient Benzyl Bromide (1.0 equiv) and the coupling partner (e.g., Aryl Iodide, 1.0 equiv).

- Note: If the benzyl bromide is a solid, add it now. If liquid, add with solvent.
- Solvation: Add anhydrous DMA (concentration relative to limiting reagent).
- Activation: Cap the vial tightly. Stir vigorously at Room Temperature for 10 minutes to complex the catalyst (solution often turns deep green/black).
- Reaction: Stir at room temperature (or mild heat, 40°C) for 12–24 hours.
 - Monitoring: Monitor by LCMS. Look for the disappearance of the benzyl bromide.
- Quench: Dilute with EtOAc, quench with 1M HCl (to dissolve excess Mn), and wash with brine.
- Purification: Flash chromatography.

Self-Validating Check: The reaction mixture must turn dark (green/black) within the first 30 minutes. If it remains pale or yellow, the

is not being generated. Check

exclusion or Mn quality (activate Mn with dilute HCl/MeOH wash if necessary).

Protocol B: Enantioselective Photoredox -Alkylation

Best for: Coupling benzyl bromides to aldehydes with high enantioselectivity. Reference: Based on MacMillan et al., J. Am. Chem. Soc. 2010 [1],[5][6]

The Science

This dual-catalytic system uses an Iridium photocatalyst to generate a benzyl radical via SET, and a chiral Organocatalyst (Amine) to activate the aldehyde as an enamine.

- Why Electron-Deficient? These substrates are perfect for this method. The resulting radical is electrophilic, matching perfectly with the nucleophilic enamine.

Materials

- Photocatalyst:

(fac-tris(2-phenylpyridinato)iridium(III)) - 1 mol%
- Organocatalyst: MacMillan Imidazolidinone (e.g., (2S,5S)-2-tert-butyl-3,5-dimethylimidazolidin-4-one) - 20 mol%
- Light Source: 26W Compact Fluorescent Light (CFL) or Blue LED (450 nm).
- Base: 2,6-Lutidine (stoichiometric acid scavenger).

Step-by-Step Protocol

- Preparation: To a clear glass vial equipped with a magnetic stir bar, add:
 - Aldehyde substrate (2.0 equiv)
 - Organocatalyst (0.2 equiv)[7]
 - (0.01 equiv)
 - Electron-Deficient Benzyl Bromide (1.0 equiv)
- Solvent: Add DMF or DMSO (0.5 M).
- Base: Add 2,6-lutidine (2.0 equiv).
- Degassing: Sparge the solution with Argon for 10 minutes (Critical: Oxygen quenches the excited Ir state).
- Irradiation: Place the vial 2–3 cm away from the light source. Stir at room temperature.
 - Fan Cooling: Use a small fan to keep the vial at ambient temperature (~25°C) to prevent thermal background reactions.
- Workup: After 12–24 hours, dilute with ether, wash with water (to remove DMF), and purify via silica gel.

Troubleshooting & Optimization Data

Solvent Effects on Yield (Ni-Coupling)

Solvent	Yield (%)	Observation
DMA	88%	Best solubility of Mn salts; stabilizes Ni species.
DMF	75%	Good, but harder to remove during workup.
THF	30%	Poor solubility of Mn/Nal; reaction stalls.
Toluene	<5%	Incompatible with polar mechanism.

Handling "Lachrymators"

Electron-deficient benzyl bromides are potent lachrymators (tear gas agents).

- Safety Rule: Always handle solids in a fume hood.
- Neutralization: Wash all glassware with a solution of 5% ethanolamine in ethanol or dilute NaOH before removing from the hood. This cleaves the C-Br bond, neutralizing the lachrymatory effect.

References

- Enantioselective
-Benzylation of Aldehydes via Photoredox Organocatalysis Shih, H.-W., Vander Wal, M. N., Grange, R. L., & MacMillan, D. W. C. (2010).^{[5][6][8][9]} J. Am. Chem. Soc. [\[Link\]](#)^[10]
- Nickel-Catalyzed Asymmetric Reductive Cross-Coupling Between Vinyl and Benzyl Electrophiles Cherney, A. H., & Reisman, S. E.^[2] (2014).^[3] J. Am. Chem. Soc. [\[Link\]](#)^[10]
- Cooperative Catalytic Coupling of Benzyl Chlorides and Bromides with Electron-Deficient Alkenes Hanumanthu, R., & Weaver, J. D.^[11] (2024).^{[12][13][14]} Org.^{[6][10][11][14][15][16]} [\[17\]](#) Lett. [\[Link\]](#)

- [Practical Guide to Suzuki-Miyaura Coupling Yoneda Labs \[Link\]](#)

Need Custom Synthesis?

BenchChem offers custom synthesis for rare earth carbides and specific isotopic labeling.

Email: info@benchchem.com or [Request Quote Online](#).

Sources

- [1. researchgate.net \[researchgate.net\]](#)
- [2. Nickel-Catalyzed Asymmetric Reductive Cross-Coupling Between Vinyl and Benzyl Electrophiles \[organic-chemistry.org\]](#)
- [3. pubs.acs.org \[pubs.acs.org\]](#)
- [4. pubs.rsc.org \[pubs.rsc.org\]](#)
- [5. Yoneda Labs \[yonedalabs.com\]](#)
- [6. Suzuki reaction - Wikipedia \[en.wikipedia.org\]](#)
- [7. sioc.cas.cn \[sioc.cas.cn\]](#)
- [8. pubs.acs.org \[pubs.acs.org\]](#)
- [9. macmillan.princeton.edu \[macmillan.princeton.edu\]](#)
- [10. youtube.com \[youtube.com\]](#)
- [11. Cooperative Catalytic Coupling of Benzyl Chlorides and Bromides with Electron-Deficient Alkenes \[organic-chemistry.org\]](#)
- [12. pubs.acs.org \[pubs.acs.org\]](#)
- [13. chem.libretexts.org \[chem.libretexts.org\]](#)
- [14. organic-chemistry.org \[organic-chemistry.org\]](#)
- [15. Best Synthetic Methods: C-C Bond Formation \[organic-chemistry.org\]](#)
- [16. researchgate.net \[researchgate.net\]](#)
- [17. Nickel-catalyzed reductive cross-coupling of aziridines and benzyl chlorides - Organic & Biomolecular Chemistry \(RSC Publishing\) \[pubs.rsc.org\]](#)
- To cite this document: BenchChem. [Application Note: C-C Bond Formation with Electron-Deficient Benzyl Bromides]. BenchChem, [2026]. [Online PDF]. Available at:

[\[https://www.benchchem.com/product/b2371299/docs#application-note-c-c-bond-formation-with-electron-deficient-benzyl-bromides\]](https://www.benchchem.com/product/b2371299/docs#application-note-c-c-bond-formation-with-electron-deficient-benzyl-bromides)

Disclaimer & Data Validity:

The information provided in this document is for Research Use Only (RUO) and is strictly not intended for diagnostic or therapeutic procedures. While BenchChem strives to provide accurate protocols, we make no warranties, express or implied, regarding the fitness of this product for every specific experimental setup.

Technical Support: The protocols provided are for reference purposes. Unsure if this reagent suits your experiment?

Need Industrial/Bulk Grade? [Request Custom Synthesis Quote](#)

BenchChem

Our mission is to be the trusted global source of essential and advanced chemicals, empowering scientists and researchers to drive progress in science and industry.

Contact

Address: 3281 E Guasti Rd
Ontario, CA 91761, United States
Phone: (601) 213-4426
Email: info@benchchem.com

[Contact our Ph.D. Support Team for a compatibility check](#)