

Technical Support Center: Palladium Remediation in Piperidine-Pyrazole Scaffolds

Author: BenchChem Technical Support Team. **Date:** April 2026

Compound of Interest

Compound Name: 4-(4-Iodo-1H-pyrazol-3-yl)piperidine

CAS No.: 2169643-37-0

Cat. No.: B2370993

[Get Quote](#)

Subject: Removing palladium impurities from **4-(4-Iodo-1H-pyrazol-3-yl)piperidine** products

Ticket ID: PD-REM-4492 Assigned Specialist: Dr. A. Vance, Senior Application Scientist

Executive Summary & Diagnostic Triage

You are likely encountering difficulty removing palladium (Pd) from **4-(4-Iodo-1H-pyrazol-3-yl)piperidine** because the molecule itself acts as a chelating ligand. The secondary amine of the piperidine and the nitrogen atoms of the pyrazole ring create a "coordination trap," effectively competing with standard washing agents for the metal.

Furthermore, the iodine substituent on the pyrazole ring restricts your options: you cannot use reductive methods (e.g., catalytic hydrogenation or Zn/acid washes) without risking hydrodehalogenation (cleaving the C-I bond).

Immediate Action Required: Stop using loose activated charcoal (carbon). For this specific basic amine scaffold, loose carbon often results in high yield loss due to non-specific adsorption of the product. Switch to functionalized silica scavengers.

The Core Solution: Functionalized Silica Scavenging

For piperidine-containing APIs, the "Gold Standard" remediation method is the use of Thiol- or Dimercaptotriazine (DMT)-functionalized silica. These scavengers rely on the high affinity of sulfur for palladium, which is thermodynamically stronger than the nitrogen-palladium bond holding the impurity to your product.

Mechanism of Action

The following diagram illustrates why standard washes fail and how the scavenger breaks the complex.

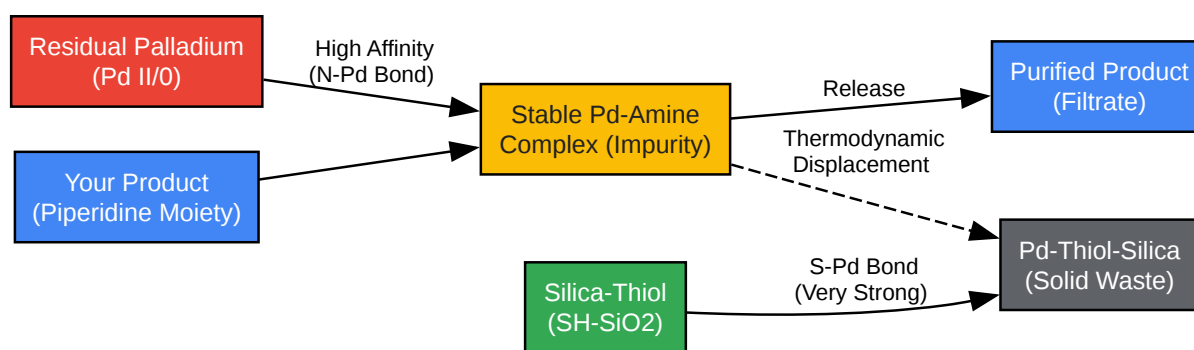

[Click to download full resolution via product page](#)

Figure 1: Chelation Competition. The sulfur ligands on the scavenger outcompete the piperidine nitrogen for the palladium metal center.

Recommended Protocol (Batch Mode)

This protocol is optimized for **4-(4-Iodo-1H-pyrazol-3-yl)piperidine**.

- Dissolution: Dissolve your crude product in a polar organic solvent.
 - Preferred: THF, DMF, or MeOH/DCM (1:1).
 - Note: Ensure the product is fully soluble.^[1] If the Pd is trapped inside undissolved solid particles, the scavenger cannot reach it.

- Scavenger Addition: Add SiliaMetS® Thiol or SiliaMetS® DMT.[2]
 - Loading: Start with 4 equivalents relative to the estimated residual Pd (or 10-20% w/w relative to the product if Pd content is unknown).
- Thermal Activation (Critical): Heat the mixture to 50–60°C for 4–12 hours.
 - Why? Ligand exchange kinetics are slow at room temperature for stable Pd-amine complexes. Heat provides the activation energy to break the N-Pd bond.
- Filtration: Filter the suspension through a 0.45 µm pad (Celite or membrane) to remove the silica-Pd complex.
- Analysis: Test filtrate via ICP-MS.

Comparative Efficiency Data

Method	Pd Removal Efficiency	Yield Recovery	Risk Factor
Thiol-Silica (Recommended)	>95%	>90%	Low (Chemically Inert)
DMT-Silica	>98%	>90%	Low (High Specificity)
Activated Carbon (Loose)	60-80%	<70%	High (Product Loss)
Crystallization	Variable (10-50%)	Variable	High (Pd Inclusion in Lattice)
Aqueous Extraction (EDTA)	<20%	>95%	High (Ineffective for N-Pd)

Troubleshooting & FAQs

Q1: The filtrate is still colored/dark after scavenging. Does this mean Pd is still present?

A: Not necessarily. Color is a poor proxy for Pd content.[3] Conjugated organic impurities (oligomers) often cause color even at ppb metal levels. Conversely, colloidal Pd can be invisible. Always rely on ICP-MS or XRF data.

- Diagnostic: If ICP shows low Pd but color persists, the color is organic. If ICP shows high Pd, see Q2.

Q2: ICP-MS shows high Pd levels even after using Thiol silica. Why?

A: You likely have Colloidal Palladium (nanoparticles) rather than soluble Pd(II) complexes. Standard functionalized silica targets soluble Pd species. Colloids can pass through standard filters.

- Fix: Add a Charcoal-based filter aid (e.g., Ecosorb®) in combination with the Thiol silica, or use a finer filtration membrane (0.2 μm). The charcoal physically adsorbs the nanoparticles, while the Thiol chemically binds the soluble Pd.

Q3: Can I use crystallization to clean this up?

A: We advise against relying solely on crystallization for this molecule. Piperidine derivatives often co-crystallize with Palladium salts. The Pd can become occluded within the crystal lattice, making it impossible to wash off. Scavenging should be done before the final crystallization step.

Q4: Will the Thiol scavenger react with the Iodine on my pyrazole?

A: No. Thiol-functionalized silica (e.g., propylthiol grafted silica) is nucleophilic but generally not reactive enough to displace an aryl/heteroaryl iodide under the recommended scavenging conditions (neutral pH, 50-60°C). It is much safer than using zinc, magnesium, or catalytic hydrogenation, which would almost certainly dehalogenate your product.

Regulatory Context (ICH Q3D)

When developing this process for pharmaceutical applications, you must adhere to ICH Q3D guidelines.

- Class 2B Element: Palladium is classified as a Class 2B impurity (low probability of occurrence in nature, but high probability if added as catalyst).
- Permitted Daily Exposure (PDE):
 - Oral: 100 μ g/day (approx. 10 ppm for a 10g daily dose).[4]
 - Parenteral (Injection): 10 μ g/day (approx. 1 ppm for a 10g daily dose).

Workflow Visualization for Compliance:

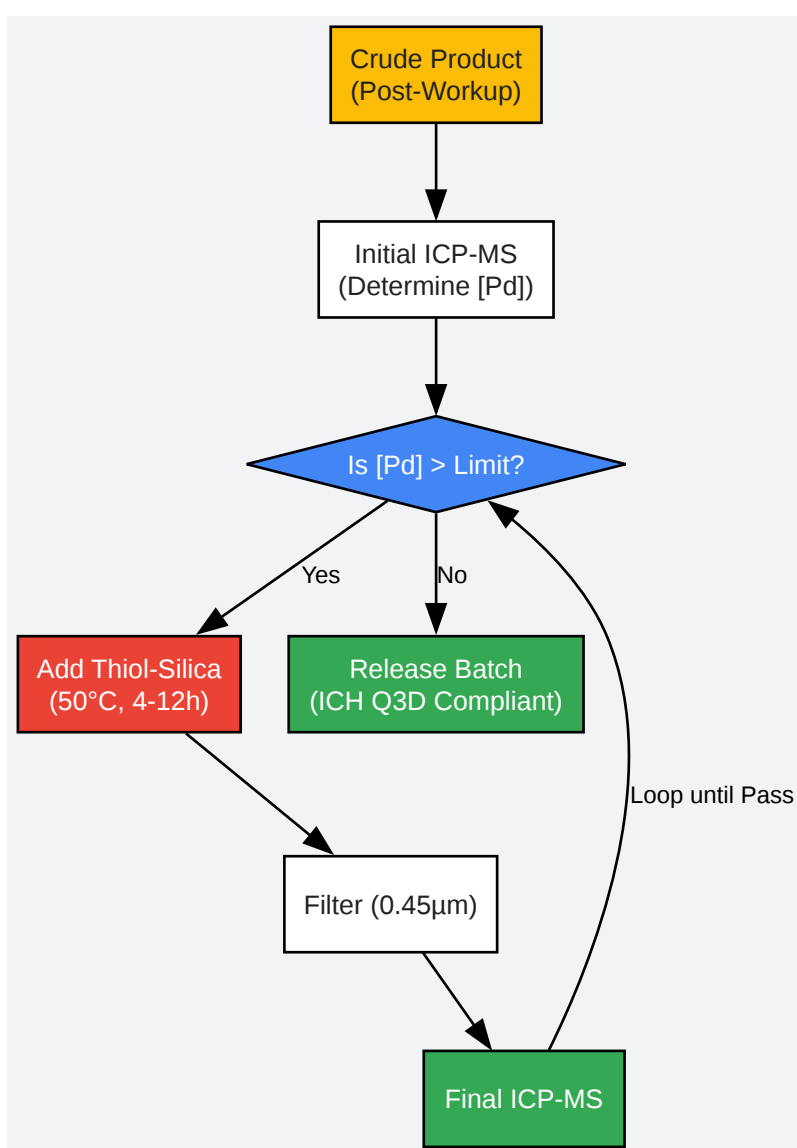

[Click to download full resolution via product page](#)

Figure 2: Iterative Remediation Workflow to meet ICH Q3D specifications.

References

- Garrett, C. E., & Prasad, K. (2004). The Art of Meeting Palladium Specifications in Active Pharmaceutical Ingredients Produced by Pd-Catalyzed Reactions. *Advanced Synthesis & Catalysis*, 346(8), 889–900. [Link](#)
- ICH Expert Working Group. (2019). ICH Q3D(R1): Guideline for Elemental Impurities. International Council for Harmonisation.[5][6] [Link](#)
- SiliCycle Inc. (2023). SiliaMetS® Metal Scavengers: User Guide & Selection Chart. SiliCycle Application Notes. [Link](#)
- Welch, C. J., et al. (2005). Adsorbent Screening for Metal Impurity Removal in Pharmaceutical Process Research. *Organic Process Research & Development*, 9(2), 198–205. [Link](#)

Need Custom Synthesis?

BenchChem offers custom synthesis for rare earth carbides and specific isotopic labeling.

Email: info@benchchem.com or [Request Quote Online](#).

Sources

- 1. [mdpi.com](https://www.mdpi.com) [[mdpi.com](https://www.mdpi.com)]
- 2. [velocityscientific.com.au](https://www.velocityscientific.com.au) [[velocityscientific.com.au](https://www.velocityscientific.com.au)]
- 3. [catsci.com](https://www.catsci.com) [[catsci.com](https://www.catsci.com)]
- 4. [triphasepharmasolutions.com](https://www.triphasepharmasolutions.com) [[triphasepharmasolutions.com](https://www.triphasepharmasolutions.com)]
- 5. [biotage.com](https://www.biotage.com) [[biotage.com](https://www.biotage.com)]
- 6. [interlabor.ch](https://www.interlabor.ch) [[interlabor.ch](https://www.interlabor.ch)]
- To cite this document: BenchChem. [Technical Support Center: Palladium Remediation in Piperidine-Pyrazole Scaffolds]. BenchChem, [2026]. [Online PDF]. Available at: [<https://www.benchchem.com/product/b2370993/docs#technical-support-center-palladium-remediation-in-piperidine-pyrazole-scaffolds>]

Disclaimer & Data Validity:

The information provided in this document is for Research Use Only (RUO) and is strictly not intended for diagnostic or therapeutic procedures. While BenchChem strives to provide accurate protocols, we make no warranties, express or implied, regarding the fitness of this product for every specific experimental setup.

Technical Support: The protocols provided are for reference purposes. Unsure if this reagent suits your experiment?

Need Industrial/Bulk Grade? [Request Custom Synthesis Quote](#)

BenchChem

Our mission is to be the trusted global source of essential and advanced chemicals, empowering scientists and researchers to drive progress in science and industry.

Contact

Address: 3281 E Guasti Rd
Ontario, CA 91761, United States
Phone: (601) 213-4426
Email: info@benchchem.com

[Contact our Ph.D. Support Team for a compatibility check](#)