

A Comparative Guide to the Mass Spectrometry Fragmentation Patterns of Boc-Oxopiperazines

Author: BenchChem Technical Support Team. **Date:** May 2026

Compound of Interest

Compound Name: *Tert-butyl 2-ethyl-3-oxopiperazine-1-carboxylate*

CAS No.: *1101840-55-4*

Cat. No.: *B2367158*

[Get Quote](#)

For Researchers, Scientists, and Drug Development Professionals

Introduction: The Analytical Imperative for Boc-Oxopiperazines in Drug Discovery

The oxopiperazine scaffold is a privileged structure in medicinal chemistry, appearing in a diverse array of therapeutic agents. Its conformational rigidity and ability to present substituents in well-defined spatial orientations make it an attractive building block for drug design. The tert-butyloxycarbonyl (Boc) protecting group is frequently employed during the synthesis of oxopiperazine-containing molecules to mask the reactivity of the piperazine nitrogen.^{[1][2]} Accurate and unambiguous characterization of these Boc-protected intermediates is paramount to ensure the integrity of multi-step synthetic campaigns.

Electrospray Ionization Mass Spectrometry (ESI-MS), particularly in tandem with collision-induced dissociation (CID), is a powerful tool for the structural elucidation of these molecules.^{[3][4][5]} Understanding the characteristic fragmentation patterns of Boc-oxopiperazines is not

merely an academic exercise; it is a critical component of reaction monitoring, impurity profiling, and the confirmation of molecular identity.

This guide provides an in-depth comparison of the mass spectrometry fragmentation patterns of Boc-oxopiperazines. We will delve into the mechanistic rationale behind the observed fragment ions, compare the fragmentation of positional isomers, and provide a robust experimental protocol for acquiring high-quality tandem mass spectrometry (MS/MS) data.

The Foundational Fragmentation Pathways: A Tale of Two Moieties

The fragmentation of Boc-oxopiperazines under CID conditions is dominated by the interplay between the labile Boc group and the heterocyclic oxopiperazine core. The initial charge site, typically a protonated nitrogen atom in positive-ion ESI, dictates the subsequent bond cleavages.

The Signature of the Boc Group: A Cascade of Neutral Losses

The tert-butoxycarbonyl protecting group is notoriously labile under mass spectrometric conditions and its fragmentation provides a clear diagnostic signature.^{[4][6]} The primary fragmentation channels involve the loss of:

- Isobutylene (56 Da): A characteristic loss resulting from a McLafferty-type rearrangement, leading to a carbamic acid intermediate that can subsequently decarboxylate.^{[7][8]} This is often the most prominent fragmentation pathway.
- tert-Butyl radical (57 Da): Resulting in an even-electron fragment ion.
- tert-Butanol (74 Da): A less common loss, but can be observed.^[3]
- Boc group as a radical (100 Da) or neutral molecule (101 Da): Representing the complete loss of the protecting group.

These fragmentation events are highly diagnostic for the presence of a Boc group and often represent the initial steps in the fragmentation cascade.

Fragmentation of the Oxopiperazine Core: Ring Opening and Cleavage

Following or concurrent with the fragmentation of the Boc group, the oxopiperazine ring undergoes characteristic cleavages. The position of the carbonyl group (the "oxo" moiety) significantly influences the fragmentation pathways. Common fragmentation patterns for piperazine-like structures involve the cleavage of the C-N bonds within the ring, leading to a variety of smaller fragment ions.^[5] The presence of the electron-withdrawing carbonyl group can influence the preferred sites of bond cleavage.

Comparative Fragmentation Analysis: The Impact of Isomerism

The diagnostic power of mass spectrometry is most evident when differentiating between isomers. In the case of Boc-oxopiperazines, the position of the carbonyl group (e.g., 2-oxo vs. 3-oxo) will produce distinct fragmentation patterns.

Fragment Ion	Proposed Structure	Likely Precursor	Significance
[M+H-56]	Carbamic acid intermediate	Boc-2-oxopiperazine / Boc-3-oxopiperazine	Ubiquitous fragment for Boc-protected amines.
[M+H-100]	Protonated oxopiperazine	Boc-2-oxopiperazine / Boc-3-oxopiperazine	Complete loss of the Boc group.
m/z 85	Retro-Diels-Alder fragment	Boc-2-oxopiperazine	Potentially more favorable from the 2-oxo isomer due to the enamide-like structure.
m/z 56	C ₃ H ₆ N ⁺	Boc-2-oxopiperazine / Boc-3-oxopiperazine	Common fragment from piperazine ring cleavage.
m/z 43	C ₂ H ₃ O ⁺ (acetylation)	Boc-2-oxopiperazine	Likely arises from cleavage adjacent to the carbonyl in the 2-oxo isomer.
m/z 70	C ₄ H ₈ N ⁺	Boc-3-oxopiperazine	May be more prominent from the 3-oxo isomer after initial ring opening.

Visualizing the Fragmentation Pathways

The following diagrams illustrate the proposed core fragmentation pathways for Boc-2-oxopiperazine and Boc-3-oxopiperazine.

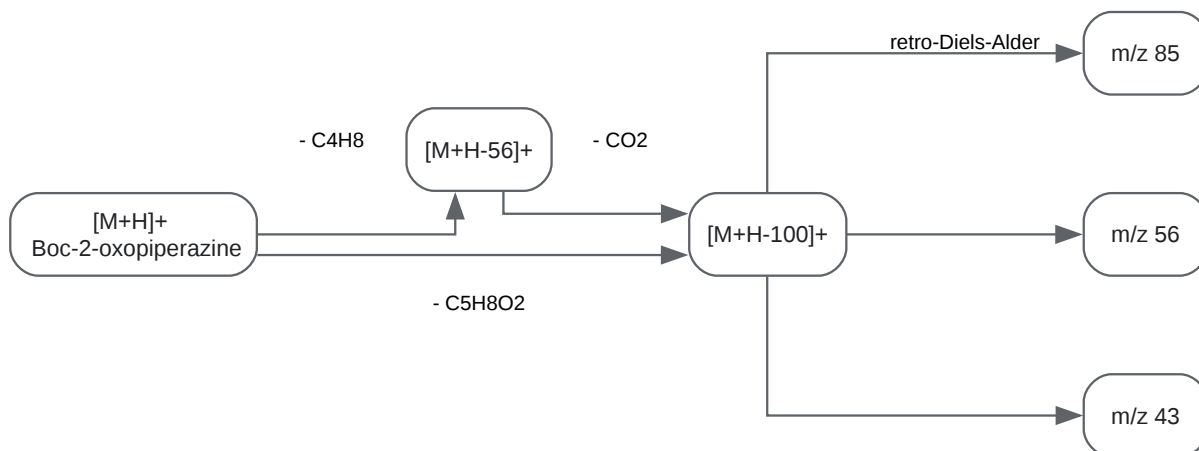

[Click to download full resolution via product page](#)

Caption: Proposed fragmentation of Boc-2-oxopiperazine.

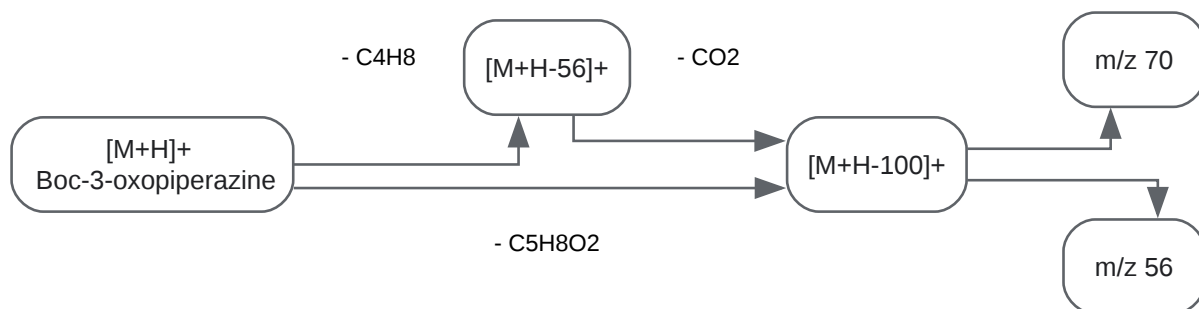

[Click to download full resolution via product page](#)

Caption: Proposed fragmentation of Boc-3-oxopiperazine.

Experimental Protocol for High-Fidelity MS/MS Analysis

This protocol outlines a robust method for acquiring high-quality MS/MS data for Boc-oxopiperazines using a standard electrospray ionization quadrupole time-of-flight (ESI-Q-TOF) mass spectrometer. The principles can be adapted for other tandem mass spectrometry platforms.

Sample Preparation

- Rationale: Proper sample preparation is crucial to avoid ion suppression and ensure efficient ionization.
- Procedure:
 - Prepare a stock solution of the Boc-oxopiperazine sample at 1 mg/mL in methanol or acetonitrile.
 - Dilute the stock solution to a final concentration of 1-10 µg/mL in a mobile phase-mimicking solvent (e.g., 50:50 acetonitrile:water with 0.1% formic acid).
 - Filter the final solution through a 0.22 µm syringe filter if any particulate matter is visible.

Mass Spectrometer and ESI Source Parameters

- Rationale: Optimization of source parameters ensures stable and efficient generation of the protonated molecular ion, $[M+H]^+$.
- Typical Parameters:
 - Ionization Mode: Positive
 - Capillary Voltage: 3.5 - 4.5 kV
 - Nebulizer Gas (N₂): 1.5 - 2.5 Bar
 - Drying Gas (N₂): 8 - 12 L/min
 - Drying Gas Temperature: 180 - 220 °C
 - Scan Range (MS1): m/z 50 - 500

MS/MS (CID) Parameters

- Rationale: The collision energy is the most critical parameter for obtaining informative fragment ion spectra. A stepped collision energy approach is recommended to capture both low-energy (Boc group loss) and higher-energy (ring fragmentation) processes.

- Procedure:
 - Perform an initial MS1 scan to identify the m/z of the protonated molecule [M+H]⁺.
 - Set up a product ion scan experiment, selecting the [M+H]⁺ ion as the precursor.
 - Apply a stepped collision energy profile. For example:
 - Collision Energy 1: 10 eV (to observe facile losses of the Boc group)
 - Collision Energy 2: 20 eV (to induce further fragmentation of the [M+H-56]⁺ and [M+H-100]⁺ ions)
 - Collision Energy 3: 40 eV (to promote extensive ring cleavage and generate smaller fragment ions)
 - Set the product ion scan range to m/z 30 - [M+H]⁺ + 5.

Data Analysis Workflow

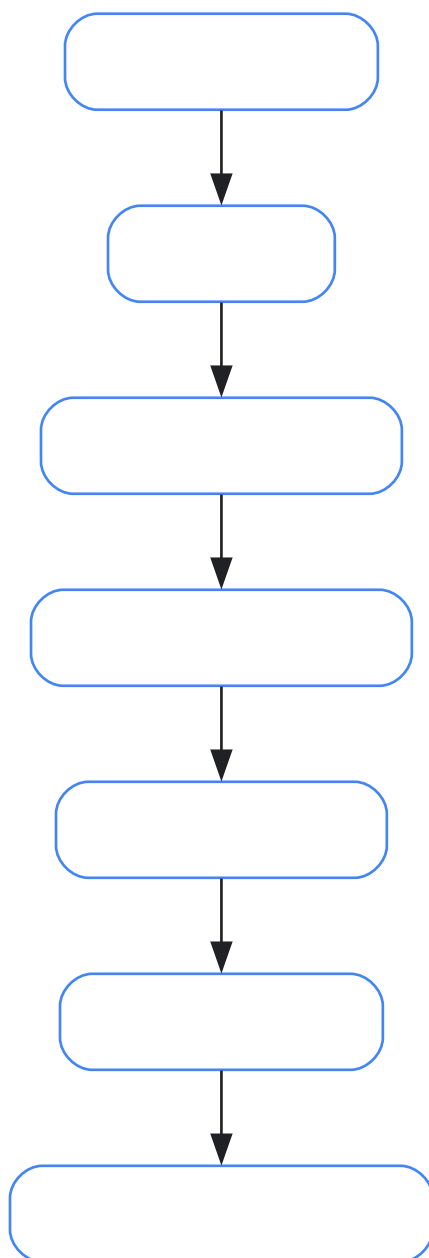

[Click to download full resolution via product page](#)

Caption: Workflow for MS/MS data analysis.

Conclusion: A Powerful Tool for Structural Verification

The mass spectrometric fragmentation of Boc-oxopiperazines is a predictable and informative process, governed by the characteristic behavior of the Boc protecting group and the

oxopiperazine core. By understanding these fundamental pathways and employing a systematic analytical approach, researchers can confidently verify the structure of their synthetic intermediates. The subtle yet significant differences in the fragmentation of positional isomers, as highlighted in this guide, underscore the power of tandem mass spectrometry as a tool for detailed structural elucidation in the fast-paced environment of drug discovery and development.

References

- ACD/Labs. (2008, December 1). Confirmation of Synthesis: using MS to identify a protective group. [\[Link\]](#)^[6]
- Reddy, P. N., et al. (2010). Differentiation of Boc-protected alpha,delta-/delta,alpha- and beta,delta-/delta,beta-hybrid peptide positional isomers by electrospray ionization tandem mass spectrometry. *Journal of Mass Spectrometry*, 45(8), 931-942. [\[Link\]](#)^[3]
- Liu, C., et al. (2025). Mass Fragmentation Characteristics of t-Boc Substituted Drug Precursors. *Journal of Chinese Mass Spectrometry Society*, 46(1), 40-47. [\[Link\]](#)^[4]
- Gäb, F., et al. (2005). Elucidation of the Presence and Location of t-Boc Protecting Groups in Amines and Dipeptides Using On-Column H/D Exchange HPLC/ESI-MS. *Journal of the American Society for Mass Spectrometry*, 16(4), 553-564. [\[Link\]](#)^[7]
- Zhu, N., et al. (2022). Mass Fragmentation Characteristics of Piperazine Analogues. *Journal of Chinese Mass Spectrometry Society*. [\[Link\]](#)^[5]
- Reddit. (2023, June 11). I knew about the MS fragmentation pattern with Boc protected amines, but didn't realize until recently that the M-56 peak might be due to a McLafferty-like fragmentation. *r/OrganicChemistry*. [\[Link\]](#)^[8]
- Reddy, P. N., et al. (2007). Electrospray ionization tandem mass spectrometric study on the effect of N-terminal beta- and gamma-carbo amino acids on fragmentation of GABA-hybrid peptides. *Journal of the American Society for Mass Spectrometry*, 18(4), 651-662. [\[Link\]](#)^[9]
- Organic Chemistry Portal. Boc-Protected Amino Groups. [\[Link\]](#)^[2]

Need Custom Synthesis?

BenchChem offers custom synthesis for rare earth carbides and specific isotopic labeling.

Email: info@benchchem.com or [Request Quote Online](#).

Sources

- [1. benchchem.com \[benchchem.com\]](https://www.benchchem.com)
- [2. Boc-Protected Amino Groups \[organic-chemistry.org\]](https://www.organic-chemistry.org)
- [3. Differentiation of Boc-protected alpha,delta-/delta,alpha- and beta,delta-/delta,beta-hybrid peptide positional isomers by electrospray ionization tandem mass spectrometry - PubMed \[pubmed.ncbi.nlm.nih.gov\]](#)
- [4. Mass Fragmentation Characteristics of Boc Substituted Drug Precursors \[zpxb.xml-journal.net\]](#)
- [5. Mass Fragmentation Characteristics of Piperazine Analogues \[zpxb.xml-journal.net\]](#)
- [6. acdlabs.com \[acdlabs.com\]](https://www.acdlabs.com)
- [7. fileserver-az.core.ac.uk \[fileserver-az.core.ac.uk\]](https://fileserver-az.core.ac.uk)
- [8. reddit.com \[reddit.com\]](https://www.reddit.com)
- [9. Electrospray ionization tandem mass spectrometric study on the effect of N-terminal beta- and gamma-carbo amino acids on fragmentation of GABA-hybrid peptides - PubMed \[pubmed.ncbi.nlm.nih.gov\]](#)
- To cite this document: BenchChem. [A Comparative Guide to the Mass Spectrometry Fragmentation Patterns of Boc-Oxopiperazines]. BenchChem, [2026]. [Online PDF]. Available at: [<https://www.benchchem.com/product/b2367158/docs#a-comparative-guide-to-the-mass-spectrometry-fragmentation-patterns-of-boc-oxopiperazines>]

Disclaimer & Data Validity:

The information provided in this document is for Research Use Only (RUO) and is strictly not intended for diagnostic or therapeutic procedures. While BenchChem strives to provide accurate protocols, we make no warranties, express or implied, regarding the fitness of this product for every specific experimental setup.

Technical Support: The protocols provided are for reference purposes. Unsure if this reagent suits your experiment?

Need Industrial/Bulk Grade? [Request Custom Synthesis Quote](#)

BenchChem

Our mission is to be the trusted global source of essential and advanced chemicals, empowering scientists and researchers to drive progress in science and industry.

Contact

Address: 3281 E Guasti Rd

Ontario, CA 91761, United States

Phone: (601) 213-4426

Email: info@benchchem.com

[Contact our Ph.D. Support Team for a compatibility check](#)