

Application Notes and Protocols for NBC19 in Flow Cytometry

Author: BenchChem Technical Support Team. **Date:** April 2026

Compound of Interest

Compound Name: NBC19
Cat. No.: B2364002

[Get Quote](#)

Introduction

NBC19 is a novel agent designed to target the CD19 surface protein, a key marker for B-lymphocytes and a prevalent target in B-cell malignancies. Flow cytometry is an indispensable tool for characterizing the binding of **NBC19** and elucidating its functional effects on target cells.[1][2][3] These application notes provide detailed protocols for key flow cytometry-based assays relevant to the preclinical and clinical development of **NBC19**.

Application 1: Immunophenotyping and Target Cell Quantification

This application describes the use of fluorochrome-conjugated **NBC19** for the identification and quantification of CD19-positive (CD19+) B-cells within a mixed population of human peripheral blood mononuclear cells (PBMCs).

Experimental Protocol: Immunophenotyping of Human PBMCs

- **Sample Preparation:** Isolate PBMCs from whole blood using density gradient centrifugation (e.g., with Ficoll-Paque™).[4] Wash the cells twice with cold phosphate-buffered saline

(PBS).

- Cell Counting and Viability: Determine cell concentration and viability using a hemocytometer and Trypan blue exclusion or an automated cell counter. Adjust the cell suspension to 1×10^7 cells/mL in Flow Cytometry Staining Buffer.[4]
- Staining:
 - Aliquot 100 μ L of the cell suspension (1×10^6 cells) into 12x75 mm flow cytometry tubes.
 - Add 5 μ L of fluorochrome-conjugated **NBC19** to the designated tubes. For multi-color analysis, add other antibodies as required (e.g., anti-CD3 for T-cells, anti-CD14 for monocytes).
 - Incubate for 30 minutes at 2-8°C, protected from light.[1]
- Wash: Add 2 mL of Flow Cytometry Staining Buffer and centrifuge at 300-400 x g for 5 minutes.[1] Discard the supernatant. Repeat the wash step once.
- Data Acquisition: Resuspend the cell pellet in 500 μ L of Flow Cytometry Staining Buffer and acquire events on a flow cytometer.[1]

Data Presentation: Quantification of CD19+ Cells

The following table presents illustrative data from the analysis of PBMCs from healthy donors versus patients with B-cell leukemia.

Sample Group	Number of Donors (n)	Mean Percentage of CD19+ Cells in Lymphocyte Gate (\pm SD)
Healthy Donors	10	8.5% (\pm 2.1%)
B-cell Leukemia Patients	10	75.2% (\pm 12.5%)

Workflow Diagram: Immunophenotyping

Immunophenotyping Workflow

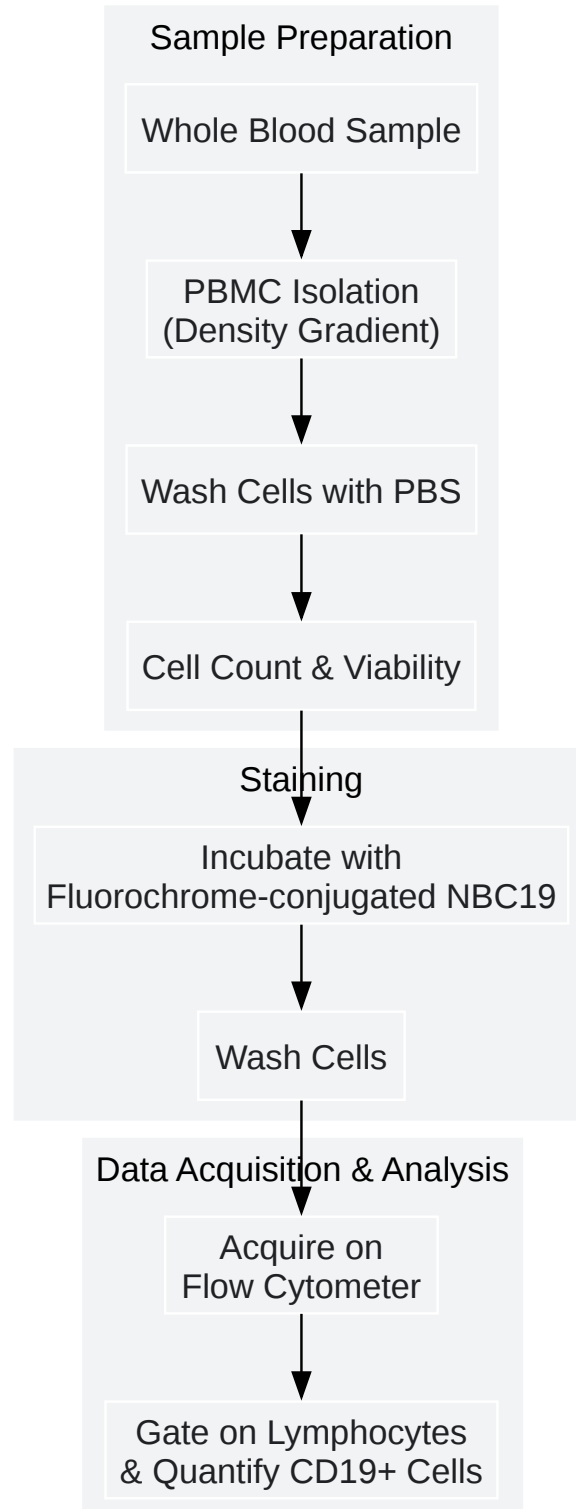

[Click to download full resolution via product page](#)

Caption: Workflow for identifying CD19+ cells.

Application 2: Cell Cycle Analysis

This protocol details how to assess the effect of **NBC19** on the cell cycle progression of a CD19-positive cancer cell line. This is crucial for understanding the antiproliferative mechanisms of **NBC19**.^{[5][6]}

Experimental Protocol: Cell Cycle Analysis of **NBC19**-Treated Cells

- Cell Culture and Treatment:
 - Seed a CD19-positive cell line (e.g., a B-cell lymphoma line) at a density of 0.5×10^6 cells/mL.
 - Treat the cells with varying concentrations of **NBC19** or a vehicle control for 48 hours.
- Cell Harvesting: Harvest the cells by centrifugation at $270 \times g$ for 5 minutes.^[7]
- Fixation:
 - Wash the cell pellet once with ice-cold PBS.
 - Resuspend the cells in 200 μ L of PBS and add 2 mL of ice-cold 70% ethanol dropwise while vortexing gently to prevent clumping.
 - Incubate at 4°C for at least 2 hours (or overnight).^[7]
- Staining for DNA Content:
 - Centrifuge the fixed cells and discard the ethanol.
 - Resuspend the cell pellet in 500 μ L of PBS containing RNase A (to degrade RNA) and propidium iodide (PI) or another DNA-binding dye.^{[7][8]}
 - Incubate in the dark at 37°C for 30 minutes.^[7]
- Data Acquisition: Analyze the samples on a flow cytometer, ensuring data is collected on a linear scale to properly resolve DNA content peaks.^[6]

Data Presentation: Effect of **NBC19** on Cell Cycle Distribution

The table below shows hypothetical results of cell cycle analysis after treating a B-cell lymphoma line with **NBC19**.

Treatment	Concentration (μM)	% Cells in G0/G1 Phase	% Cells in S Phase	% Cells in G2/M Phase
Vehicle Control	0	45.3%	38.1%	16.6%
NBC19	1	68.2%	15.5%	16.3%
NBC19	10	79.5%	8.3%	12.2%

These illustrative data suggest that **NBC19** induces G0/G1 cell cycle arrest.

Signaling Pathway Diagram: CD19-Mediated Proliferation

Simplified CD19 Signaling

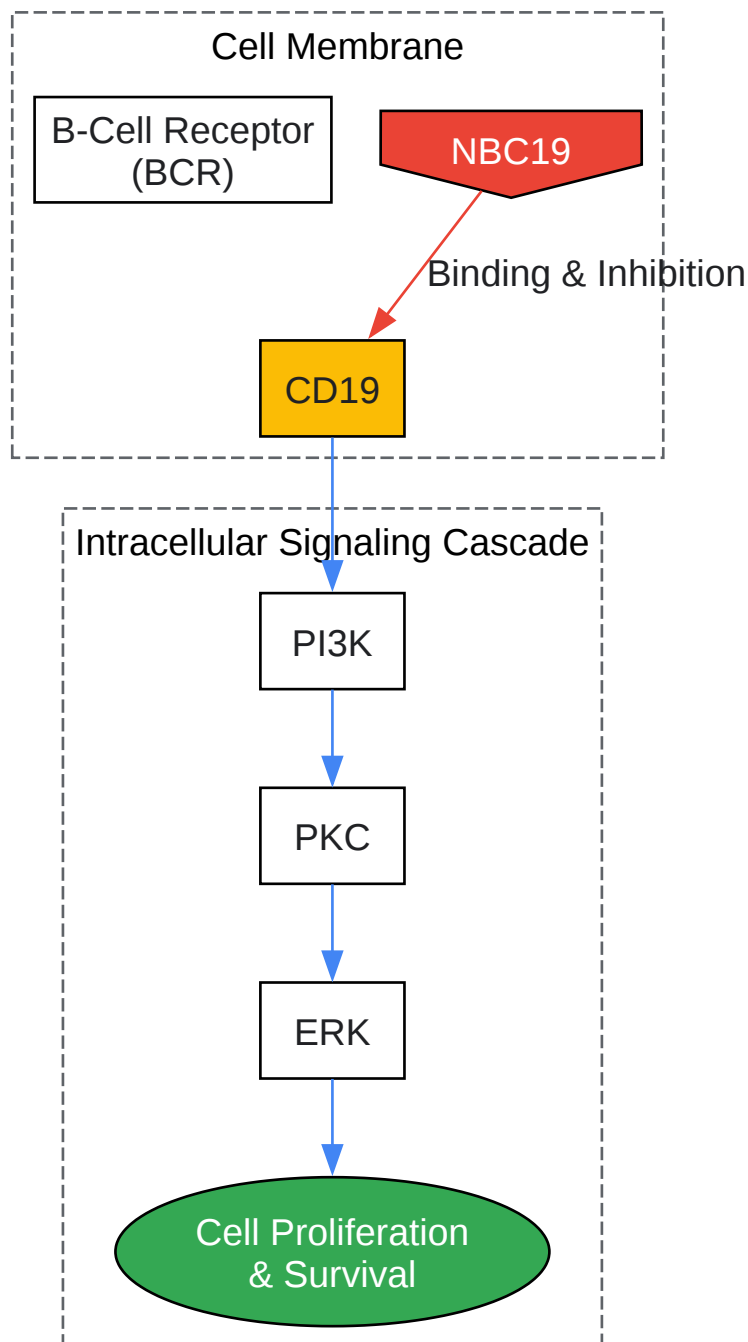

[Click to download full resolution via product page](#)

Need Custom Synthesis?

BenchChem offers custom synthesis for rare earth carbides and specific isotopic labeling.

Email: info@benchchem.com or [Request Quote Online](#).

References

- [1. tools.thermofisher.com](https://tools.thermofisher.com) [tools.thermofisher.com]
- [2. Translational applications of flow cytometry in clinical practice - PubMed](#) [pubmed.ncbi.nlm.nih.gov]
- [3. piedmontcmg.com](https://piedmontcmg.com) [piedmontcmg.com]
- [4. research.pasteur.fr](https://research.pasteur.fr) [research.pasteur.fr]
- [5. researchgate.net](https://researchgate.net) [researchgate.net]
- [6. bio-rad-antibodies.com](https://bio-rad-antibodies.com) [bio-rad-antibodies.com]
- [7. assaygenie.com](https://assaygenie.com) [assaygenie.com]
- [8. Cell Cycle Assays for Flow Cytometry | Thermo Fisher Scientific - JP](#) [thermofisher.com]
- To cite this document: BenchChem. [Application Notes and Protocols for NBC19 in Flow Cytometry]. BenchChem, [2026]. [Online PDF]. Available at: [<https://www.benchchem.com/product/b2364002/docs#application-notes-and-protocols-for-nbc19-in-flow-cytometry>]

Disclaimer & Data Validity:

The information provided in this document is for Research Use Only (RUO) and is strictly not intended for diagnostic or therapeutic procedures. While BenchChem strives to provide accurate protocols, we make no warranties, express or implied, regarding the fitness of this product for every specific experimental setup.

Technical Support: The protocols provided are for reference purposes. Unsure if this reagent suits your experiment?

Need Industrial/Bulk Grade? [Request Custom Synthesis Quote](#)

BenchChem

Our mission is to be the trusted global source of essential and advanced chemicals, empowering scientists and researchers to drive progress in science and industry.

Contact

Address: 3281 E Guasti Rd
Ontario, CA 91761, United States
Phone: (601) 213-4426
Email: info@benchchem.com

[Contact our Ph.D. Support Team for a compatibility check](#)