

# Technical Support Center: Stability & Synthesis of Difluoromethyl ( ) Motifs

**Author:** BenchChem Technical Support Team. **Date:** May 2026

## Compound of Interest

Compound Name: (2S)-2-(Difluoromethyl)oxirane

CAS No.: 2056095-67-9

Cat. No.: B2362114

[Get Quote](#)

Ticket ID: CF2H-STABILITY-001 Status: Open Agent: Senior Application Scientist Subject: Minimizing HF Elimination Side Reactions in Difluoromethyl Compounds

## Diagnostic Hub: Identify Your Issue

Select the symptom that best matches your experimental observation to jump to the relevant troubleshooting step.

Symptom	Probable Cause	Immediate Action
Black/Tarry Reaction Mixture	Uncontrolled Decomposition: Rapid HF elimination leading to polymerization of transient carbenes/azafulvenes.	Check Base Strength. If , switch to a milder base (e.g., , ).
High Conversion, Low Isolated Yield	Aqueous Workup Hydrolysis: The group survived the reaction but hydrolyzed during basic workup.	Quench with Buffer. Use pH 7 phosphate buffer instead of NaOH/NaHCO . Avoid heating during workup.
Formation of Aldehydes ( )	Oxidative Defluorination: The group was converted to a carbene and subsequently hydrolyzed.	Exclude Water/Hydroxide. Ensure anhydrous conditions. If using radical conditions, lower oxidant equivalents.
Etching of Glassware	Free Fluoride Generation: Significant HF release is occurring.[1]	Add Lewis Acid Scavenger. Add or use plastic/Teflon vessels to prevent autocatalytic glass etching.

## The Knowledge Base: Mechanisms of Instability

To prevent HF elimination, you must understand the E1cB (Elimination Unimolecular conjugate Base) mechanism. The

proton is surprisingly acidic (

in arenes, lower in sulfones/carbonyls) due to the electron-withdrawing effect of the two fluorine atoms.

## The E1cB Pathway (The "Death Spiral")

When a base removes the proton, the resulting carbanion is stabilized by the fluorines (inductive effect) but destabilized by lone-pair repulsion (p-orbital overlap). To relieve this, it ejects a fluoride ion (

), forming a highly reactive difluorocarbene or fluoro-alkene intermediate that rapidly decomposes.

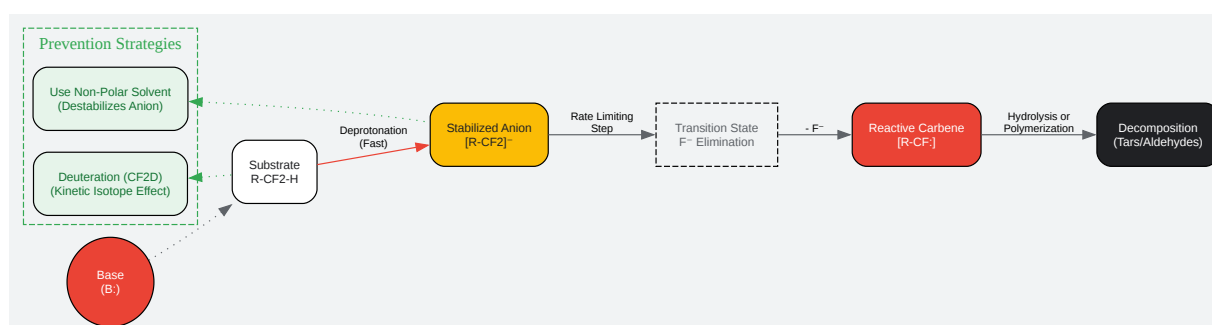

[Click to download full resolution via product page](#)

Figure 1: The E1cB mechanism leading to HF elimination and decomposition. Green nodes indicate intervention points.

## Prevention Protocols & Optimization

### A. Base & Solvent Selection Matrix

The choice of base/solvent pair is critical. Polar aprotic solvents (DMSO, DMF) significantly enhance the basicity of anions, accelerating E1cB elimination.

Solvent Class	Risk Level	Recommended Bases	Notes
Polar Aprotic (DMF, DMSO)	HIGH	,	Avoid alkoxides ( , ). The "naked" anion effect promotes deprotonation.
Polar Protic (MeOH, EtOH)	MEDIUM	,	Solvation of anions reduces reactivity, but elimination is still possible if heated.
Non-Polar (DCM, Toluene)	LOW	,	Preferred System. Ion-pairing tightens the anion, making elimination kinetically difficult.

## B. The Deuterium Firewall (Kinetic Isotope Effect)

If your

compound is unstable, switch to a

analog.

- Mechanism: The C-D bond is stronger than the C-H bond. This introduces a Primary Kinetic Isotope Effect (KIE), slowing down the rate-determining deprotonation step ( ).
- Implementation: Use reagents like or deuterated sulfinates (

). This is a validated strategy in late-stage drug modification to improve metabolic stability (preventing CYP450 oxidation) and chemical stability.

## C. Reagent Selection: Radical vs. Nucleophilic

Choose the pathway that avoids "anionic residence time."

- Radical Pathways (Preferred for Heterocycles):
  - Reagent: Zinc Difluoromethanesulfinate (DFMS) or  
-photocatalysis with  
.
  - Advantage:[\[2\]](#)[\[3\]](#)[\[4\]](#)[\[5\]](#) Radical intermediates (  
) are neutral and do not undergo E1cB elimination.
  - Risk:[\[2\]](#)[\[6\]](#)[\[7\]](#) Over-oxidation to a cation (  
) which hydrolyzes. Control: Regulate oxidant strength.
- Nucleophilic Pathways:
  - Reagent:  
(Hu's Reagent).
  - Risk:[\[2\]](#)[\[7\]](#) Requires fluoride initiation (  
or TBAT), generating a naked anion.
  - Fix: Use Lewis Acid buffering (e.g.,  
salts) to stabilize the intermediate alkoxide/anion.

## Validated Experimental Protocol

Workflow: Late-Stage Radical Difluoromethylation of Heteroarenes without HF Loss

This protocol minimizes HF elimination by using a mild oxidant and avoiding strong bases.

## Materials

- Substrate: Heteroarene (1.0 equiv)
- Reagent: Zinc Difluoromethanesulfinate (DFMS, Baran's Reagent) (3.0 equiv)
- Oxidant: tert-Butyl hydroperoxide (TBHP) (70% aq., 3.0 equiv) OR Persulfate ( )
- Solvent: DCM/Water (biphasic) or DMSO (if substrate is insoluble)
- Additive: Trifluoroacetic acid (TFA) (1.0 equiv) – Crucial for protonating basic nitrogens to prevent base-mediated elimination.

## Step-by-Step Procedure

- Setup: In a vial equipped with a Teflon-coated stir bar, dissolve the heteroarene in DCM ( ).
- Acidification (The Safety Lock): Add TFA (1.0 equiv).
  - Why? Protonating the heterocycle renders it more electrophilic (better for radical attack) and neutralizes any basic sites that could trigger E1cB elimination of the product.
- Reagent Addition: Add DFMS (solid) followed by water (0.5 volume relative to DCM).
- Initiation: Add TBHP dropwise at , then warm to Room Temperature (RT).
  - Why? Low temp prevents thermal elimination during the initial exotherm.
- Monitoring: Stir vigorously. Monitor by  $^{19}\text{F}$  NMR (look for doublet at to

ppm).

- Troubleshooting: If you see a singlet at  
  
ppm, that is free fluoride (  
  
). Stop reaction and extract immediately.
- Workup (Critical):
  - Dilute with DCM.
  - Do NOT wash with strong base (  
  
).
  - Wash with Saturated  
  
(mild) or Phosphate Buffer (pH 7).
  - Dry over  
  
and concentrate at <40°C.

## Troubleshooting Logic Tree

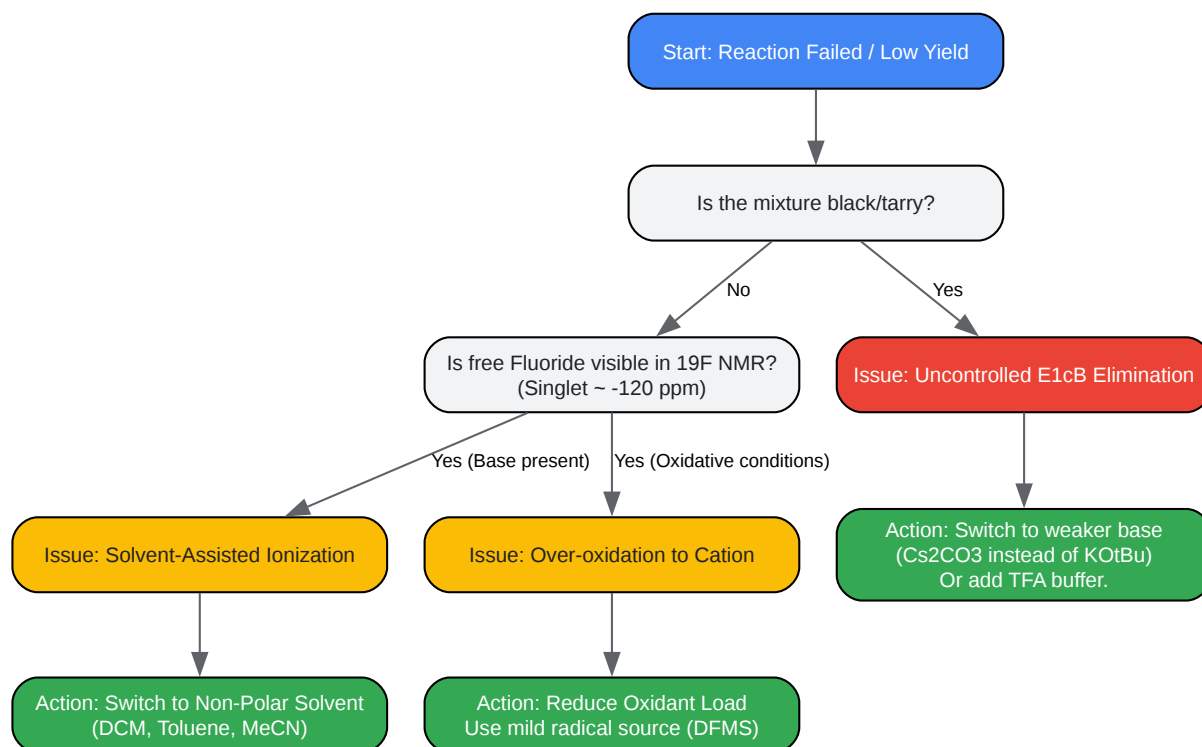

[Click to download full resolution via product page](#)

Figure 2: Decision matrix for diagnosing difluoromethylation failures.

## References

- E1cB Mechanism & Fluorine Elimination
  - Master Organic Chemistry. (2020).[1][4][8] "The E1cB Mechanism." [Link](#)
  - Wikipedia. "E1cB-elimination reaction." [Link](#)
- Difluoromethylation Reagents & Strategies
  - Hu, J., et al.[7] (2014). "Nucleophilic, radical, and electrophilic (phenylsulfonyl)difluoromethylations." *Journal of Fluorine Chemistry*. [Link](#)

- Baran, P. S., et al.[7] (2012).[6] "Practical Difluoromethylation of Heterocycles via Zinc Difluoromethanesulfinate." (Contextual reference for DFMS protocols).
- Bioisosteres & Stability (H-Bonding)
  - Prakash, G. K. S., et al.[7][9] (2019).[1][10] "CF<sub>2</sub>H, a Hydrogen Bond Donor." [6][11] NIH/PMC. [Link](#)
  - Meanwell, N. A.[7] (2018).[10][12] "Fluorine and Fluorinated Motifs in the Design and Application of Bioisosteres for Drug Design." Journal of Medicinal Chemistry. [Link](#)
- Radical Mechanisms & Side Reactions
  - MacMillan, D. W. C., et al.[7] (2020).[1][4][8] "Photocatalytic Difluoromethylation Reactions." NIH/PMC. [Link](#)

### Need Custom Synthesis?

BenchChem offers custom synthesis for rare earth carbides and specific isotopic labeling.

Email: [info@benchchem.com](mailto:info@benchchem.com) or [Request Quote Online](#).

## Sources

- 1. [pubs.acs.org](https://pubs.acs.org) [[pubs.acs.org](https://pubs.acs.org)]
- 2. CF<sub>2</sub>H: a fascinating group for application in drug development enabling modulation of many molecular properties - PMC [[pmc.ncbi.nlm.nih.gov](https://pubmed.ncbi.nlm.nih.gov/)]
- 3. [researchgate.net](https://www.researchgate.net) [[researchgate.net](https://www.researchgate.net)]
- 4. Direct C–H difluoromethylation of heterocycles via organic photoredox catalysis - PMC [[pmc.ncbi.nlm.nih.gov](https://pubmed.ncbi.nlm.nih.gov/)]
- 5. Difluoromethylation of heterocycles via a radical process - Organic Chemistry Frontiers (RSC Publishing) [[pubs.rsc.org](https://pubs.rsc.org)]
- 6. Facile Entry to Pharmaceutically Important 3-Difluoromethyl-Quinoxalin-2-Ones Enabled by Visible-Light-Driven Difluoromethylation of Quinoxalin-2-Ones - PMC [[pmc.ncbi.nlm.nih.gov](https://pubmed.ncbi.nlm.nih.gov/)]
- 7. [sioc.cas.cn](https://www.sioc.cas.cn) [[sioc.cas.cn](https://www.sioc.cas.cn)]

- [8. masterorganicchemistry.com \[masterorganicchemistry.com\]](https://www.masterorganicchemistry.com)
- [9. pubs.acs.org \[pubs.acs.org\]](https://pubs.acs.org)
- [10. Difluoroalkane synthesis by fluorination or substitution \[organic-chemistry.org\]](https://www.organic-chemistry.org)
- [11. researchgate.net \[researchgate.net\]](https://www.researchgate.net)
- [12. Late-stage difluoromethylation: concepts, developments and perspective - Chemical Society Reviews \(RSC Publishing\) DOI:10.1039/D1CS00360G \[pubs.rsc.org\]](https://pubs.rsc.org)
- To cite this document: BenchChem. [Technical Support Center: Stability & Synthesis of Difluoromethyl ( ) Motifs]. BenchChem, [2026]. [Online PDF]. Available at: [\[https://www.benchchem.com/product/b2362114/docs#technical-support-center-stability-synthesis-of-difluoromethyl-motifs\]](https://www.benchchem.com/product/b2362114/docs#technical-support-center-stability-synthesis-of-difluoromethyl-motifs)

---

### Disclaimer & Data Validity:

The information provided in this document is for Research Use Only (RUO) and is strictly not intended for diagnostic or therapeutic procedures. While BenchChem strives to provide accurate protocols, we make no warranties, express or implied, regarding the fitness of this product for every specific experimental setup.

**Technical Support:** The protocols provided are for reference purposes. Unsure if this reagent suits your experiment?

**Need Industrial/Bulk Grade?** [Request Custom Synthesis Quote](#)

## BenchChem

Our mission is to be the trusted global source of essential and advanced chemicals, empowering scientists and researchers to drive progress in science and industry.

### Contact

Address: 3281 E Guasti Rd

Ontario, CA 91761, United States

Phone: (601) 213-4426

Email: [info@benchchem.com](mailto:info@benchchem.com)

Contact our Ph.D. Support Team for a compatibility check