

Introduction: The Critical Role of Stability in Advanced Chemical Entities

Author: BenchChem Technical Support Team. **Date:** May 2026

Compound of Interest

Compound Name: *8-(2-bromoacetyl)naphthalene-2-carbonitrile*

CAS No.: 2088942-88-3

Cat. No.: B2359460

[Get Quote](#)

8-(2-bromoacetyl)naphthalene-2-carbonitrile is a bespoke molecule featuring a rigid naphthalene scaffold functionalized with a reactive α -bromoacetyl group and a polar nitrile moiety. Such polyfunctional molecules are of significant interest in medicinal chemistry and materials science, often serving as key intermediates or active pharmaceutical ingredients (APIs). The α -haloketone functional group, in particular, is a versatile precursor for the synthesis of various heterocyclic compounds, some of which exhibit notable biological activity. [1][2] However, the very reactivity that makes this molecule synthetically useful also raises critical questions about its thermodynamic stability.

Understanding the thermodynamic stability of a compound like **8-(2-bromoacetyl)naphthalene-2-carbonitrile** is not an academic exercise; it is a fundamental requirement for its safe handling, storage, formulation, and ultimate application. Thermal instability can lead to decomposition, resulting in loss of efficacy, the formation of potentially toxic byproducts, and compromised shelf-life. This guide provides a comprehensive framework for evaluating the thermodynamic stability of this molecule, integrating theoretical principles with robust experimental and computational methodologies. We will explore not just what to do, but why each step is critical for building a complete and reliable stability profile.

Theoretical Underpinnings of Molecular Stability

The thermodynamic stability of a molecule is fundamentally governed by its Gibbs free energy (G). A system naturally seeks its lowest energy state, and a chemical compound is considered "stable" under a given set of conditions if it resides in a significant thermodynamic energy well. The spontaneity of a decomposition reaction is determined by the change in Gibbs free energy (ΔG):

$$\Delta G = \Delta H - T\Delta S$$

Where:

- ΔH (Enthalpy) represents the change in heat content. Exothermic decompositions (negative ΔH) are energetically favorable.
- ΔS (Entropy) represents the change in disorder. Decomposition reactions that produce multiple smaller molecules, particularly gases, have a large positive ΔS and are favored entropically.
- T is the absolute temperature.

A negative ΔG indicates a spontaneous process. Therefore, a molecule's stability is a function of both its inherent bond energies (enthalpy) and the entropic penalty of its ordered structure, assessed at a specific temperature. Our goal is to determine the conditions, particularly temperature, under which the decomposition of **8-(2-bromoacetyl)naphthalene-2-carbonitrile** becomes spontaneous.

Anticipated Decomposition Pathways: A Mechanistic Perspective

The structure of **8-(2-bromoacetyl)naphthalene-2-carbonitrile** contains several features that suggest potential degradation routes. The α -haloketone moiety is the most probable site of initial decomposition.

- **C-Br Bond Cleavage:** The carbon-bromine bond is inherently weaker than C-C or C-H bonds and is polarized by the adjacent electron-withdrawing carbonyl group, making it susceptible to both nucleophilic attack and homolytic cleavage upon thermal stress.^[2]

- HBr Elimination: The presence of a hydrogen atom on the carbon adjacent to the carbonyl group can facilitate the elimination of hydrogen bromide (HBr), a corrosive and toxic gas, to form an α,β -unsaturated ketone.[1][3] This is a common decomposition pathway for α -haloketones.
- Hydrolysis: In the presence of moisture, the bromoacetyl group can be susceptible to hydrolysis, replacing the bromine with a hydroxyl group. While this is more a matter of chemical compatibility, it can occur at elevated temperatures if water is present.

A logical diagram of a primary decomposition pathway is presented below.

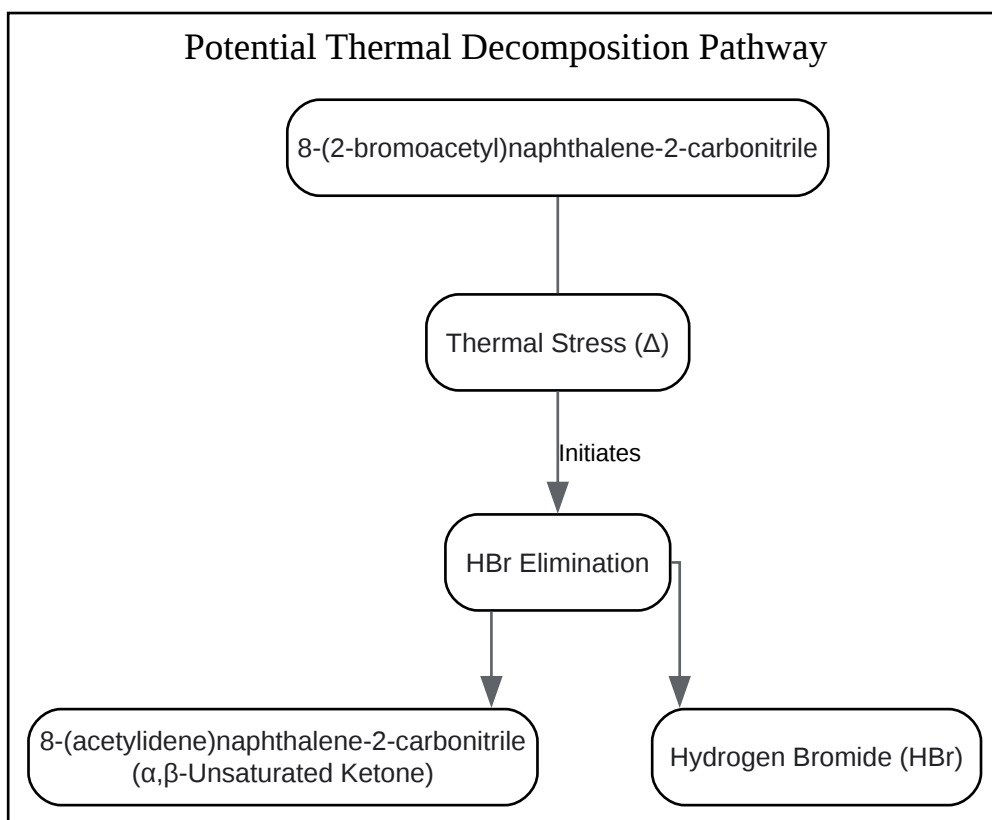

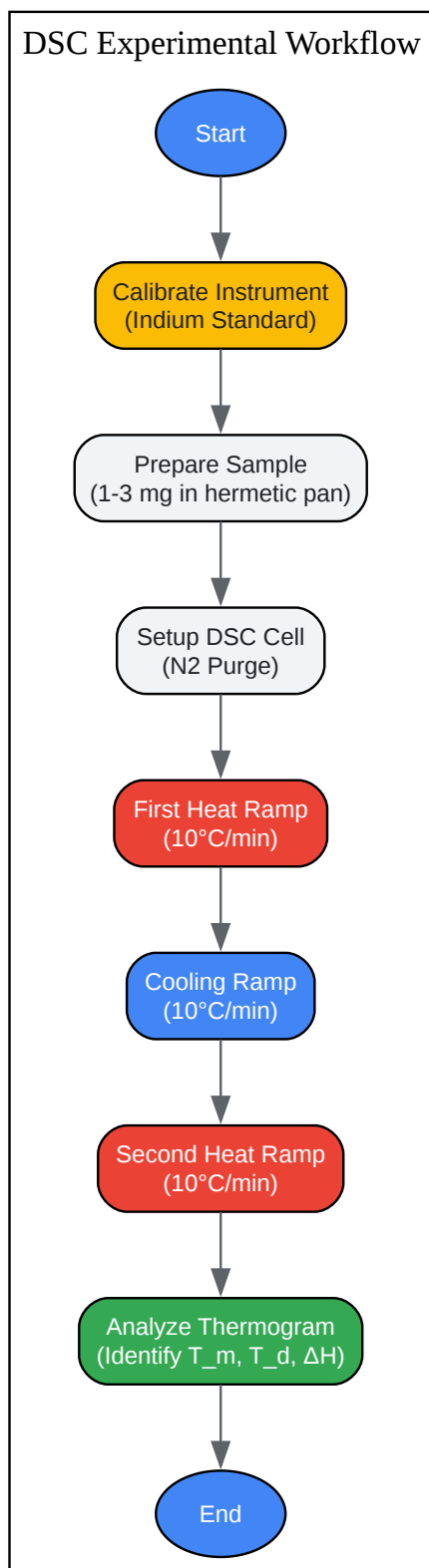

[Click to download full resolution via product page](#)

Caption: A self-validating workflow for DSC analysis.

Computational Assessment: Predicting Stability from First Principles

While experimental methods are the gold standard, computational chemistry offers a powerful, predictive tool for assessing thermodynamic stability before a molecule is even synthesized.

[4]By calculating the heat of formation (ΔH_f), we can compare the relative stability of the parent molecule to its potential decomposition products. [5][6] Methodology: Density Functional Theory (DFT) Calculations

- **Structure Optimization:** The 3D structure of **8-(2-bromoacetyl)naphthalene-2-carbonitrile** is computationally built. A geometry optimization calculation is performed (e.g., using the B3LYP functional and a 6-31G* basis set) to find the lowest energy conformation of the molecule.
- **Frequency Calculation:** A frequency calculation is performed on the optimized geometry. **Causality:** This step is crucial for two reasons. First, it confirms that the structure is a true energy minimum (no imaginary frequencies). Second, it provides the zero-point vibrational energy (ZPVE) and thermal corrections needed to calculate enthalpy and Gibbs free energy at a specific temperature (e.g., 298.15 K). [5]3. **Energy Calculation:** A high-accuracy single-point energy calculation is performed on the optimized geometry using a larger basis set to obtain a more precise electronic energy.
- **Thermochemical Analysis:** The heat of formation and Gibbs free energy are calculated using the results from the above steps. This process is repeated for the suspected decomposition products (e.g., the α,β -unsaturated ketone and HBr).
- **Reaction Energetics:** The overall enthalpy of decomposition (ΔH_{rxn}) can be predicted by comparing the energies of the reactant and products. A negative ΔH_{rxn} suggests an exothermic, and therefore potentially hazardous, decomposition.

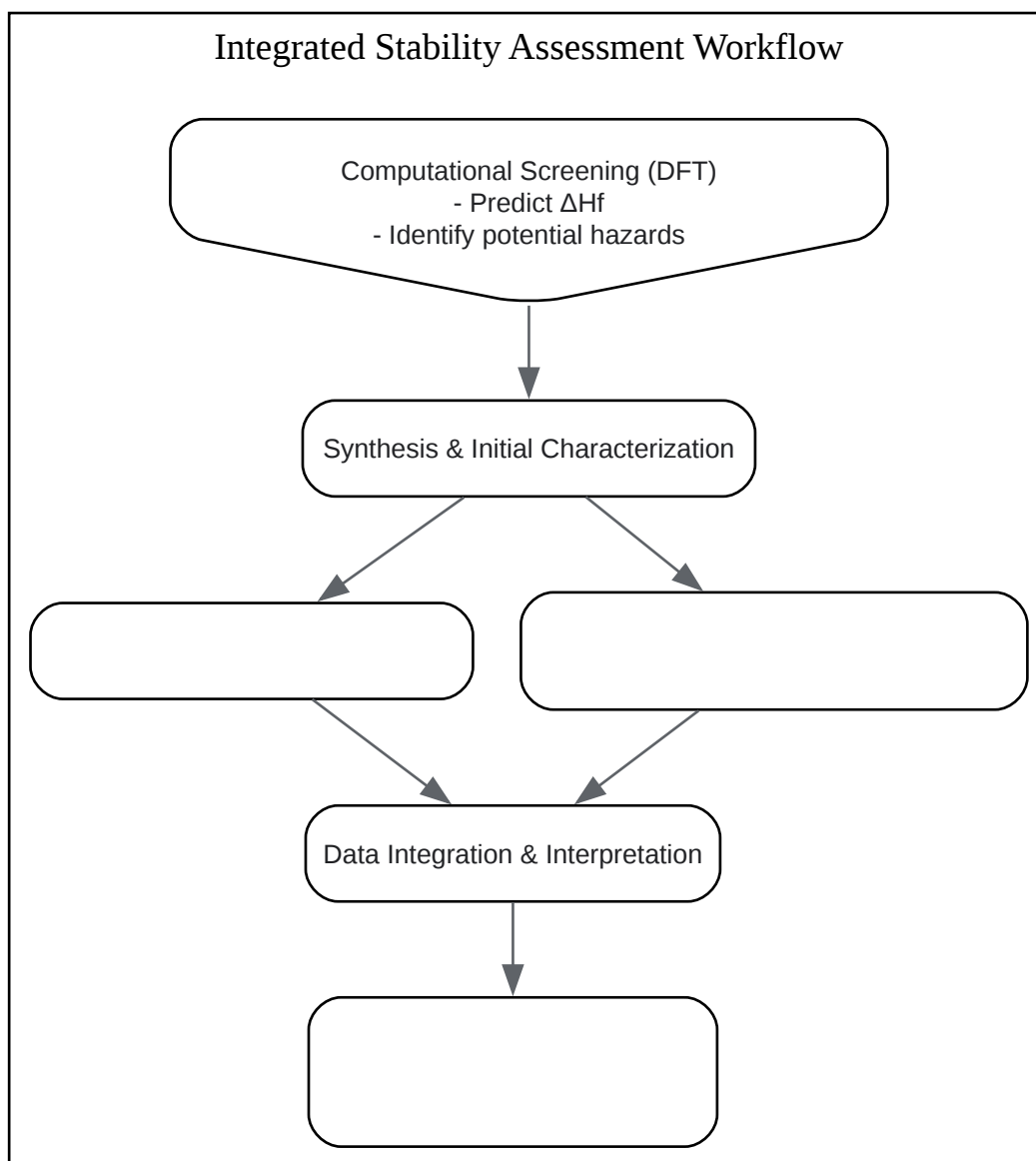

[Click to download full resolution via product page](#)

Caption: Integrated workflow for thermodynamic stability assessment.

Data Interpretation: Synthesizing a Coherent Picture

The true insight comes from integrating the computational and experimental data.

Table 1: Representative TGA Data for **8-(2-bromoacetyl)naphthalene-2-carbonitrile**

Parameter	Value	Interpretation
Onset Temperature (Tonset)	~ 215 °C	The temperature at which significant mass loss begins.
Mass Loss at 250 °C	~ 32%	Corresponds closely to the loss of HBr (MW 80.9) from the parent molecule (MW 288.1), which is ~28% mass loss.

| Residue at 500 °C | < 5% | Indicates nearly complete decomposition at higher temperatures. |

Table 2: Representative DSC Data for **8-(2-bromoacetyl)naphthalene-2-carbonitrile**

Event	Onset Temp (°C)	Peak Temp (°C)	Enthalpy (ΔH , J/g)	Interpretation
Endotherm	110.5 °C	112.8 °C	+85.2 J/g	Sharp peak characteristic of melting, indicating a crystalline solid.

| Exotherm | 218.1 °C | 225.4 °C | -450.7 J/g | A large, sharp exotherm immediately following the TGA mass loss onset, strongly indicating a rapid, energetic decomposition event. |

Integrated Analysis: The DSC data reveals a melting point around 111-113 °C. The compound is stable in its solid and liquid forms until approximately 215 °C. At this temperature, TGA shows a mass loss consistent with the elimination of HBr, and DSC shows a significant and sharp exotherm. This confluence of data provides high confidence that 215 °C is the onset of a hazardous thermal decomposition. This information is critical for setting upper temperature limits for handling, drying, and storage.

Table 3: Representative Computational Thermochemistry (DFT B3LYP/6-311+G)**

Molecule	Heat of Formation (kJ/mol)	Gibbs Free Energy (kJ/mol)
Parent Molecule	+150.2	+245.8
Unsaturated Ketone + HBr	+125.9	+201.5

| $\Delta H_{\text{reaction}}$ / $\Delta G_{\text{reaction}}$ | -24.3 kJ/mol | -44.3 kJ/mol |

The computational results support the experimental findings. The calculated negative enthalpy of reaction (ΔH) indicates the decomposition is exothermic, aligning with the DSC measurement. The negative Gibbs free energy of reaction (ΔG) confirms that the decomposition to the α,β -unsaturated ketone and HBr is thermodynamically favorable.

Conclusion and Recommendations

A multi-faceted evaluation demonstrates that **8-(2-bromoacetyl)naphthalene-2-carbonitrile** is a crystalline solid with a distinct melting point and a clear onset of thermal decomposition at approximately 215 °C. The decomposition is exothermic and likely proceeds via the elimination of hydrogen bromide.

For researchers, scientists, and drug development professionals, this leads to the following actionable recommendations:

- **Handling and Storage:** The compound should be stored in a cool, dry place, well below its decomposition onset. Temperatures should not exceed 40 °C for long-term storage to provide a wide safety margin.
- **Process Safety:** Any synthetic or formulation step involving this molecule must maintain strict temperature control to stay well below 215 °C. Scale-up operations should consider the exothermic nature of the decomposition to prevent thermal runaway.
- **Formulation:** The potential for HBr elimination should be considered during formulation. Excipients that are basic or could promote elimination reactions should be avoided.

By combining predictive computational modeling with rigorous experimental verification using TGA and DSC, we can establish a comprehensive and trustworthy thermodynamic stability

profile. This integrated approach is essential for mitigating risks and ensuring the safe and effective development of novel chemical entities.

References

- D. J. Henry, C. J. Parkinson, and L. Radom, "A Computational Chemist's Guide to Accurate Thermochemistry for Organic Molecules," Wiley Interdisciplinary Reviews: Computational Molecular Science. [[Link](#)]
- Y. F. Yuen, C. H. Lin, and S. L. Chen, "Phase Transitions of Naphthalene and Its Derivatives Confined in Mesoporous Silicas," The Journal of Physical Chemistry C, 2011. [[Link](#)]
- A. M. Reilly and A. Tkatchenko, "A complete description of thermodynamic stabilities of molecular crystals," Proceedings of the National Academy of Sciences, 2022. [[Link](#)]
- Fiveable, "Alpha-halogenation of carbonyls," Organic Chemistry II Class Notes. [[Link](#)]
- A. D. G. Firmino et al., "Polymorph Screening of Core-Chlorinated Naphthalene Diimides with Different Fluoroalkyl Side-Chain Lengths," Molecules, 2024. [[Link](#)]
- C. V. Stevens et al., "Synthetic Access to Aromatic α -Haloketones," Molecules, 2022. [[Link](#)]
- A. L. Allouche, "COMPUTATIONAL STUDY OF ORGANIC COMPOUNDS – AN APPLICATION FOR LEARNING IN CHEMISTRY," Journal of Education, Society and Behavioural Science, 2019. [[Link](#)]
- G. S. Parks, H. M. Huffman, and M. Barmore, "The Low-Temperature Thermodynamic Properties of Naphthalene, 1-Methylnaphthalene, 2-Methylnaphthalene, 1,2,3,4-Tetrahydronaphthalene, trans-Decahydronaphthalene and cis-Decahydronaphthalene," The Journal of Physical Chemistry, 1933. [[Link](#)]
- Wikipedia, "Reductive dehalogenation of halo ketones." [[Link](#)]
- Reddit, "How useful is computational chemistry as a synthetic organic chemist," r/OrganicChemistry. [[Link](#)]
- NIST, "Naphthalene," NIST Chemistry WebBook. [[Link](#)]

- Thermo Fisher Scientific, "2-(Bromoacetyl)naphthalene SAFETY DATA SHEET." [[Link](#)]
- R. O. Kareem et al., "Quantum Computing Analysis of Naphthalene Compound: Electronic Structure, Optical, and Thermochemical Approaches using DFT and HF," Journal of Applied Organometallic Chemistry, 2024. [[Link](#)]
- M. B. Fielitz, "Computational Thermodynamics," CORE. [[Link](#)]
- P. De Koninck, A. Loranger, and M. G.
- J. P. Schaefer, J. G. Higgins, and P. K. Shenoy, "2-bromonaphthalene," Organic Syntheses Procedure. [[Link](#)]
- A. S. Girgis, "The Chemistry of α -Haloketones and Their Utility in Heterocyclic Synthesis," Molecules, 2009. [[Link](#)]
- Y. Wang et al., "Synthesis of naphthalene derivatives via nitrogen-to-carbon transmutation of isoquinolines," Science, 2025. [[Link](#)]
- J. A. L. Borges et al., "Design and Synthesis of Naphthol Derivative," Journal of the Mexican Chemical Society, 2013. [[Link](#)]
- Y. B. Rokade and R. Z. Sayyed, "NAPHTHALENE DERIVATIVES : A NEW RANGE OF ANTIMICROBIALS WITH HIGH THERAPEUTIC VALUE," International Journal of ChemTech Research, 2009. [[Link](#)]
- PubChem, "2-Naphthalenecarbonitrile," National Center for Biotechnology Information. [[Link](#)]
- NIST, "2-Naphthalenecarbonitrile," NIST Chemistry WebBook. [[Link](#)]
- Wiley, "Naphthalene-2-carbonitrile, 1,2,3,4-tetrahydro-2-oxo-spiro-3-cyclohexane-," SpectraBase. [[Link](#)]
- NIST, "Naphthalene, 2-bromo-," NIST Chemistry WebBook. [[Link](#)]

Need Custom Synthesis?

BenchChem offers custom synthesis for rare earth carbides and specific isotopic labeling.

Email: info@benchchem.com or [Request Quote Online](#).

Sources

- [1. mdpi.com](https://www.mdpi.com) [[mdpi.com](https://www.mdpi.com)]
- [2. The Chemistry of \$\alpha\$ -Haloketones and Their Utility in Heterocyclic Synthesis - PMC](https://pubmed.ncbi.nlm.nih.gov/) [[pmc.ncbi.nlm.nih.gov](https://pubmed.ncbi.nlm.nih.gov/)]
- [3. fiveable.me](https://www.fiveable.me) [[fiveable.me](https://www.fiveable.me)]
- [4. reddit.com](https://www.reddit.com) [[reddit.com](https://www.reddit.com)]
- [5. scispace.com](https://www.scispace.com) [[scispace.com](https://www.scispace.com)]
- [6. ojs.ifes.edu.br](https://ojs.ifes.edu.br) [ojs.ifes.edu.br]
- To cite this document: BenchChem. [Introduction: The Critical Role of Stability in Advanced Chemical Entities]. BenchChem, [2026]. [Online PDF]. Available at: [<https://www.benchchem.com/product/b2359460/docs#introduction-the-critical-role-of-stability-in-advanced-chemical-entities>]

Disclaimer & Data Validity:

The information provided in this document is for Research Use Only (RUO) and is strictly not intended for diagnostic or therapeutic procedures. While BenchChem strives to provide accurate protocols, we make no warranties, express or implied, regarding the fitness of this product for every specific experimental setup.

Technical Support: The protocols provided are for reference purposes. Unsure if this reagent suits your experiment?

Need Industrial/Bulk Grade? [Request Custom Synthesis Quote](#)

BenchChem

Our mission is to be the trusted global source of essential and advanced chemicals, empowering scientists and researchers to drive progress in science and industry.

Contact

Address: 3281 E Guasti Rd

Ontario, CA 91761, United States

Phone: (601) 213-4426

Email: info@benchchem.com

[Contact our Ph.D. Support Team for a compatibility check](#)