

Comprehensive Spectral Analysis of 2-Hydroxy-5-(pentafluorothio)benzaldehyde

Author: BenchChem Technical Support Team. **Date:** April 2026

Compound of Interest

Compound Name: 2-Hydroxy-5-(pentafluorothio)benzaldehyde

CAS No.: 1159512-31-8

Cat. No.: B2354849

[Get Quote](#)

A Technical Guide for Medicinal Chemistry Applications

Executive Summary & Compound Profile

2-Hydroxy-5-(pentafluorothio)benzaldehyde (also known as 5-(pentafluorothio)salicylaldehyde) represents a high-value scaffold in modern drug discovery. The incorporation of the pentafluorosulfanyl (

) group—often termed the "super-trifluoromethyl" group—imparts unique lipophilicity, metabolic stability, and electronegativity to the salicylaldehyde core.

This guide provides a definitive analysis of the spectral characteristics (NMR, IR, MS) of this molecule. Unlike standard organic intermediates, the

moiety introduces complex spin systems and distinct fragmentation patterns that require specialized interpretation.

Physicochemical Profile

Property	Value / Description
Molecular Formula	
Molecular Weight	248.17 g/mol
Appearance	Pale yellow crystalline solid
Solubility	Soluble in , DMSO- , MeOH
Key Structural Feature	Hypervalent sulfur () with octahedral geometry

Synthesis & Structural Logic

To understand the spectra, one must understand the electronic environment. The molecule is synthesized via the ortho-formylation of 4-(pentafluorothio)phenol.

- **Electronic Push-Pull:** The phenolic hydroxyl (EDG) at C2 exerts a shielding effect on the ortho proton (H3), while the aldehyde (EWG) at C1 and the group (strong EWG,) at C5 strongly deshield the remaining aromatic protons.
- **Intramolecular H-Bonding:** A strong hydrogen bond exists between the phenolic proton and the carbonyl oxygen, locking the conformation and significantly shifting the OH and CHO proton signals in NMR.

Nuclear Magnetic Resonance (NMR) Spectroscopy

3.1

F NMR: The

Fingerprint

The

group exhibits a characteristic AB₄ spin system (often appearing as a doublet and a quintet) due to the octahedral geometry where four equatorial fluorines (

) are chemically equivalent but magnetically distinct from the single axial fluorine (

).

Note on Chemical Shifts: Unlike standard C-F bonds (which resonate -60 to -200 ppm),

signals typically appear in the positive ppm range relative to

Nuclei	Shift (, ppm)	Multiplicity	Coupling (, Hz)	Assignment
	+80.0 – +88.0	Quintet		Axial Fluorine
	+60.0 – +65.0	Doublet		Equatorial Fluorines

“

Expert Insight: In lower field instruments (<300 MHz), this may look like a broad multiplet. High-field (400 MHz+) is required to resolve the definitive quintet-doublet pattern.

3.2

H NMR: Aromatic Substitution Pattern

The spectrum is defined by the 1,2,5-substitution pattern.

Proton	Shift (, ppm)	Multiplicity	Coupling (, Hz)	Structural Logic
-OH	11.0 – 11.5	Singlet (br)	-	Deshielded by H-bonding to C=O.
-CHO	9.8 – 10.0	Singlet	-	Aldehyde proton; diagnostic.
H6	8.0 – 8.1	Doublet (d)		Ortho to CHO, Ortho to . Most deshielded aromatic H.
H4	7.8 – 7.9	dd	,	Ortho to , Meta to OH.
H3	7.0 – 7.1	Doublet (d)		Ortho to OH. Shielded by oxygen lone pairs.

3.3

C NMR

The carbon spectrum is complicated by C-F splitting.

- C=O: ~196 ppm.
- C-OH (C2): ~165 ppm.
- C-SF5 (C5): Appears as a quintet (Hz) around 145-150 ppm.

- C-F Coupling: Adjacent carbons (C4, C6) will show significant splitting (triplets/quintets) due to the proximity of the five fluorine atoms.

Infrared (IR) Spectroscopy

The IR spectrum confirms the functional groups and the integrity of the S-F bonds.

Frequency ()	Vibration Mode	Notes
3200 – 3400	O-H Stretch	Broad band; lower frequency due to intramolecular H-bonding.
1660 – 1675	C=O Stretch	Shifted lower (from typical 1700) due to conjugation and H-bond.
810 – 860	S-F Stretch	Diagnostic. Very strong, intense band specific to .
1580, 1480	C=C Aromatic	Skeletal vibrations.

Mass Spectrometry (MS) & Fragmentation

The

group is robust but exhibits specific fragmentation pathways under Electron Impact (EI).

- Molecular Ion (): 248 m/z (Distinct sulfur isotope pattern).
- Base Peak: Often (Loss of CHO) or the phenol cation.

Fragmentation Workflow

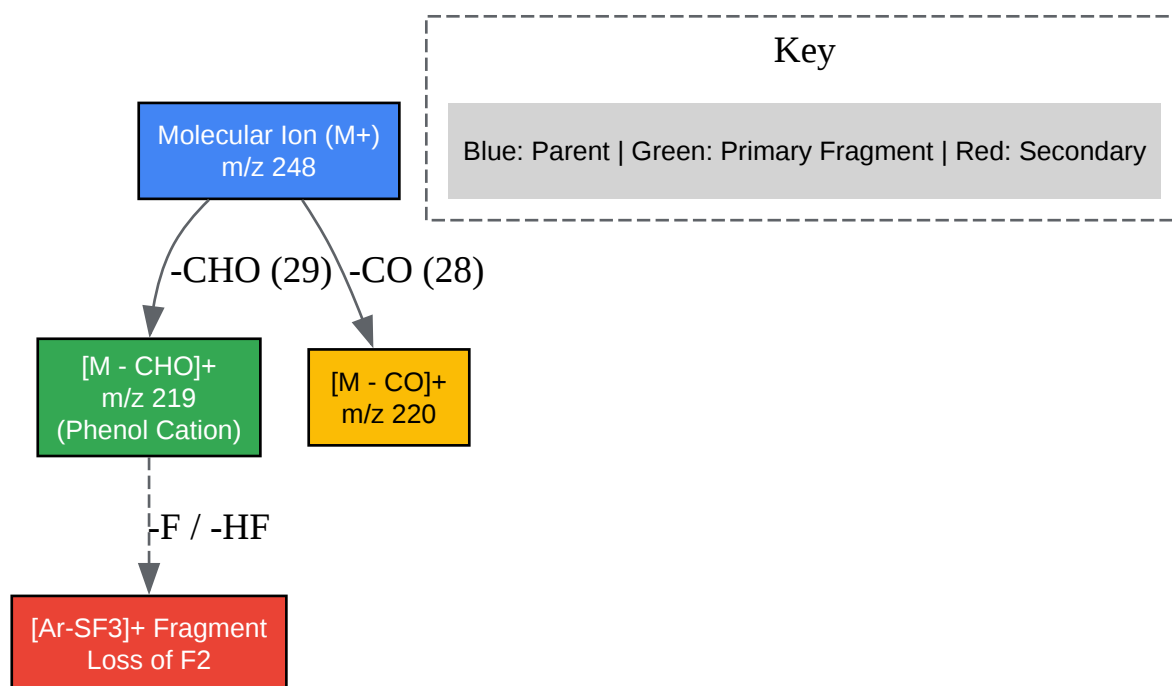

[Click to download full resolution via product page](#)

Figure 1: Predicted EI-MS fragmentation pathway for **2-Hydroxy-5-(pentafluorothio)benzaldehyde**.

Experimental Protocols

Protocol A: NMR Sample Preparation

- Solvent Choice: Use DMSO-
(0.6 mL) for optimal resolution of the phenolic proton.
is acceptable but the OH peak may be broad or drift.
- Concentration: 10-15 mg of sample.
- Tube: High-quality 5mm NMR tube (Wilmad 507-PP or equivalent) to minimize background fluorine signals.
- Parameter Set:

- ¹H: 16 scans, 30°C.
- ¹⁹F: 64 scans, spectral width expanded to +100/-200 ppm. Crucial: Reference to internal (0 ppm) or external standard.

Protocol B: GC-MS Analysis

- Column: DB-5ms or equivalent non-polar column (30m x 0.25mm).

- Inlet Temp: 250°C.

- Gradient: 60°C (hold 1 min)

280°C at 20°C/min.

- Note: The

group is thermally stable up to ~300°C, making this compound suitable for GC analysis without derivatization.

References

- Togni, A. (2021).[1] The Supramolecular Structural Chemistry of Pentafluorosulfanyl Compounds. University of Zurich. [Link](#)
- Savoie, P. R., & Welch, J. T. (2015). Preparation and Utility of Organic Pentafluorosulfanyl-Containing Compounds. *Chemical Reviews*, 115(2), 1130–1190. [Link](#)
- Alfa Chemistry. (2025). ¹⁹F NMR Chemical Shift Table - Organofluorine. [Link](#)
- Kirsch, P. (2004).
- PubChem. (2025). Compound Summary: Pentafluorosulfanyl derivatives. National Library of Medicine. [Link](#)

Need Custom Synthesis?

BenchChem offers custom synthesis for rare earth carbides and specific isotopic labeling.

Email: info@benchchem.com or [Request Quote Online](#).

Sources

- [1. opendata.uni-halle.de \[opendata.uni-halle.de\]](https://opendata.uni-halle.de)
- To cite this document: BenchChem. [Comprehensive Spectral Analysis of 2-Hydroxy-5-(pentafluorothio)benzaldehyde]. BenchChem, [2026]. [Online PDF]. Available at: [\[https://www.benchchem.com/product/b2354849/docs#comprehensive-spectral-analysis-of-2-hydroxy-5-pentafluorothio-benzaldehyde\]](https://www.benchchem.com/product/b2354849/docs#comprehensive-spectral-analysis-of-2-hydroxy-5-pentafluorothio-benzaldehyde)

Disclaimer & Data Validity:

The information provided in this document is for Research Use Only (RUO) and is strictly not intended for diagnostic or therapeutic procedures. While BenchChem strives to provide accurate protocols, we make no warranties, express or implied, regarding the fitness of this product for every specific experimental setup.

Technical Support: The protocols provided are for reference purposes. Unsure if this reagent suits your experiment?

Need Industrial/Bulk Grade? [Request Custom Synthesis Quote](#)

BenchChem

Our mission is to be the trusted global source of essential and advanced chemicals, empowering scientists and researchers to drive progress in science and industry.

Contact

Address: 3281 E Guasti Rd
Ontario, CA 91761, United States
Phone: (601) 213-4426
Email: info@benchchem.com

[Contact our Ph.D. Support Team for a compatibility check](#)

