

Technical Guide: ^{13}C -ALA vs. ^{14}C -ALA for Heme Synthesis Quantification

Author: BenchChem Technical Support Team. **Date:** March 2026

Compound of Interest

Compound Name: *5-amino-4-oxo(^{13}C)pentanoic acid;hydrochloride*

CAS No.: 129720-95-2

Cat. No.: B023908

[Get Quote](#)

Executive Summary

For decades, ^{14}C -ALA radiolabeling has been the "gold standard" for quantifying heme synthesis rates due to its extreme sensitivity and linear dynamic range. However, ^{13}C -ALA stable isotope labeling coupled with Mass Spectrometry (LC-MS/MS) has emerged as a superior alternative for mechanistic studies, offering structural resolution (isotopologue analysis) and eliminating radiation safety hazards.

- Choose ^{14}C -ALA if: You need to measure bulk synthesis rates in samples with extremely low heme turnover, or if you lack access to a high-sensitivity Triple Quadrupole Mass Spectrometer.
- Choose ^{13}C -ALA if: You require structural confirmation of the metabolite, need to distinguish de novo synthesis from salvage pathways, or operate in a radiation-free safety environment.

Scientific Foundation: The Heme Biosynthetic Pathway

To understand the labeling logic, we must visualize where 5-Aminolevulinic Acid (ALA) enters the pathway.^[1] ALA is the committed precursor; exogenous labeled ALA bypasses the rate-limiting enzyme ALA Synthase (ALAS), driving flux into the heme pool.

Pathway Diagram

The following diagram illustrates the incorporation of labeled ALA into the final Heme molecule.

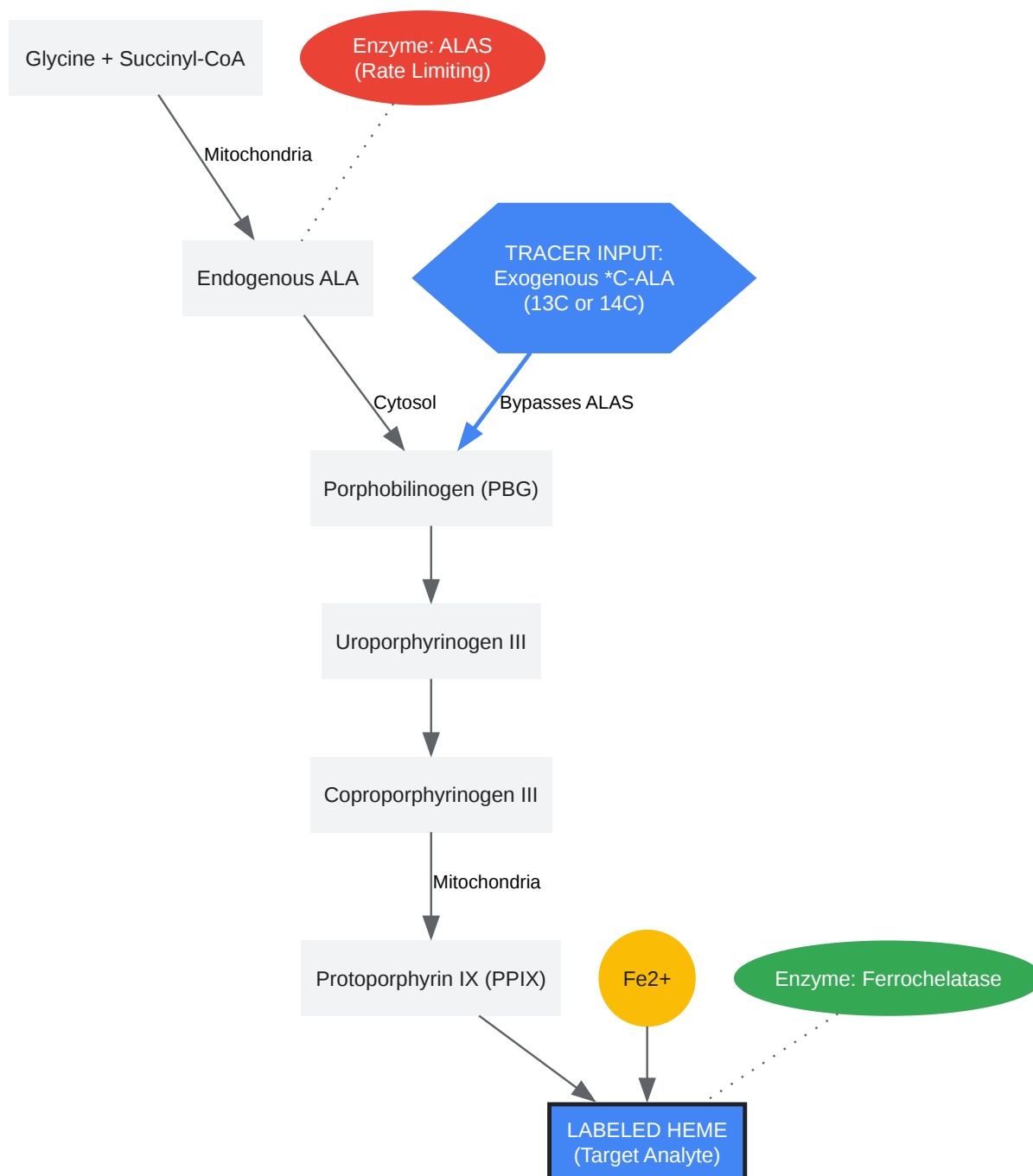

[Click to download full resolution via product page](#)

*Figure 1: Heme biosynthetic pathway showing the entry point of exogenous C-ALA tracers, bypassing the rate-limiting ALAS step.

Methodology 1: ¹⁴C-ALA Radiolabeling (The Historic Standard)

This method relies on the radioactive decay of Carbon-14. It measures the total accumulation of radioactivity in the heme fraction.^{[2][3]}

Protocol Overview

- Pre-incubation: Starve cells of glycine (optional) to sensitize the pathway.
- Labeling: Incubate cells with [4-¹⁴C]-5-ALA (typically 0.1–0.5 μCi/mL) for 4–24 hours.
- Extraction (Critical Step):
 - Lyse cells in acid-acetone to precipitate proteins.
 - Perform liquid-liquid extraction using Diethyl Ether or Ethyl Acetate.
 - Wash organic phase with dilute HCl to remove coproporphyrins (which are hydrophilic in acid).
- Quantification: Evaporate solvent, resuspend in scintillation fluid, and count (CPM) on a Liquid Scintillation Counter (LSC).

Expert Insight: The "Purity" Trap

The validity of ¹⁴C quantification depends entirely on the purity of the extraction. Since LSC counts all ¹⁴C atoms in the vial, any contaminating labeled intermediates (like PPIX or Coproporphyrin) that are not fully removed during the wash steps will be counted as "Heme," leading to false positives.

Methodology 2: ¹³C-ALA Stable Isotope Labeling (The Modern Approach)

This method uses non-radioactive isotopes detected by Mass Spectrometry (LC-MS/MS). It measures the mass shift (M+X) of the heme molecule.

Protocol Overview

- Labeling: Incubate cells with [5-¹³C]-5-ALA (typically 100–200 μM).
 - Note: High concentrations are often needed to overcome endogenous dilution.
- Extraction:
 - Lyse cells in DMSO or acidified acetonitrile/methanol.
 - Optional: Add an internal standard (e.g., deuterated Heme-d6 or Mesoporphyrin).
- Analysis: Inject onto a C18 Reverse Phase column coupled to a Triple Quadrupole MS.
- Quantification: Monitor MRM transitions.
 - Unlabeled Heme: 616.2 → 557.2 m/z
 - ¹³C-Labeled Heme: 617.2 → 558.2 m/z (for single incorporation) or higher depending on labeling efficiency.

Expert Insight: Structural Validation

Unlike ¹⁴C, LC-MS/MS separates the analyte chromatographically before detection. Even if PPIX co-elutes, its mass (562.27 Da) is distinct from Heme (616.18 Da). This makes the ¹³C method inherently more specific; you cannot mistake an intermediate for the final product.

Deep Dive Comparison

Workflow Logic Visualization

The following diagram contrasts the linear, manual nature of the ¹⁴C workflow with the automated, data-rich ¹³C workflow.

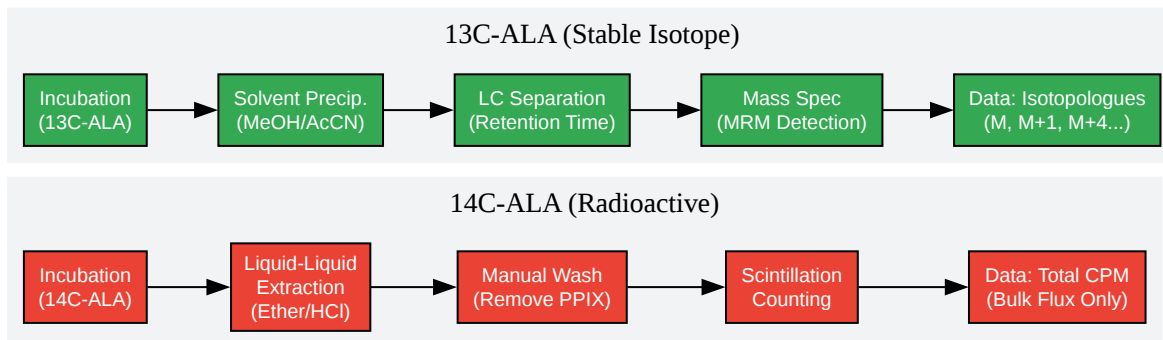

[Click to download full resolution via product page](#)

Figure 2: Comparative workflow logic. Note the manual wash steps required for 14C vs. the chromatographic separation in 13C.

Comparative Data Matrix

Feature	14C-ALA (Radioisotope)	13C-ALA (Stable Isotope)
Detection Principle	Beta-decay (Scintillation)	Mass-to-Charge Ratio (LC-MS/MS)
Sensitivity	Ultra-High (Femtomolar range)	High (Picomolar range) - Dependent on MS hardware
Specificity	Low (Relies on extraction purity)	Absolute (Retention time + Mass)
Safety	Hazardous (Radioactive waste disposal)	Safe (Benchtop handling)
Data Output	Rate (CPM/mg protein)	Rate + Isotopologue Distribution + Structural ID
Throughput	Low (Manual extractions)	High (96-well plate automated injection)
Cost	Low Equipment / High Disposal Cost	High Equipment / Low Reagent Cost

Critical Analysis & Recommendations

When to use ¹⁴C-ALA?

Despite being an older technology, ¹⁴C remains relevant in low-yield systems. If you are studying a cell line with barely detectable heme synthesis (e.g., certain non-erythroid cells under suppression), the background noise in Mass Spectrometry might mask the signal. Scintillation counting has a virtually zero background, allowing detection of minute synthesis events.

When to use ¹³C-ALA?

For drug development and mechanistic biology, ¹³C is the superior choice.

- **Multiplexing:** You can simultaneously track Heme synthesis (¹³C-ALA) and protein synthesis (¹⁵N-labeled amino acids) in the same sample.
- **Quality Control:** The MS spectrum allows you to see if the iron insertion step is blocked (accumulation of labeled PPIX vs. Heme). ¹⁴C counting cannot distinguish between a block at Ferrochelatase and a block upstream without complex differential extractions.
- **Regulatory:** No radioactive license is required, facilitating use in standard pharmaceutical CROs.

Validation Check

To ensure your ¹³C-ALA protocol is working, look for the M+4 isotopologue. Since 8 molecules of ALA condense to form one Heme, and typically 4 carbons from each ALA are retained in the porphyrin ring (depending on the specific label position, usually C4 or C5), you should see a specific mass shift pattern. If you only see M+0 (unlabeled), your tracer concentration is too low to compete with endogenous synthesis.

References

- Radiolabeling Heme and Porphyrin with ¹⁴C-Glycine or ¹⁴C δ -Aminolevulinic Acid. Source: Bio-protocol / PubMed [[Link](#)]

- Measurement of Heme Synthesis Levels in Mammalian Cells (14C Protocol). Source: Journal of Visualized Experiments (JoVE) [[Link](#)]
- LC-MS/MS detection of [13C]heme, -PPIX, and -CPP in P. falciparum. Source: Journal of Biological Chemistry [[Link](#)][4]
- Determination of heme in microorganisms using HPLC-MS/MS. Source: Analytical and Bioanalytical Chemistry [[Link](#)]

Need Custom Synthesis?

BenchChem offers custom synthesis for rare earth carbides and specific isotopic labeling.

Email: info@benchchem.com or [Request Quote Online](#).

Sources

- [1. researchgate.net \[researchgate.net\]](#)
- [2. researchgate.net \[researchgate.net\]](#)
- [3. Measurement of Heme Synthesis Levels in Mammalian Cells - PMC \[pmc.ncbi.nlm.nih.gov\]](#)
- [4. researchgate.net \[researchgate.net\]](#)
- To cite this document: BenchChem. [Technical Guide: 13C-ALA vs. 14C-ALA for Heme Synthesis Quantification]. BenchChem, [2026]. [Online PDF]. Available at: [<https://www.benchchem.com/product/b023908#13c-ala-vs-14c-ala-radiolabeling-for-heme-synthesis-quantification>]

Disclaimer & Data Validity:

The information provided in this document is for Research Use Only (RUO) and is strictly not intended for diagnostic or therapeutic procedures. While BenchChem strives to provide accurate protocols, we make no warranties, express or implied, regarding the fitness of this product for every specific experimental setup.

Technical Support: The protocols provided are for reference purposes. Unsure if this reagent suits your experiment? [[Contact our Ph.D. Support Team for a compatibility check](#)]

Need Industrial/Bulk Grade? [Request Custom Synthesis Quote](#)

BenchChem

Our mission is to be the trusted global source of essential and advanced chemicals, empowering scientists and researchers to drive progress in science and industry.

Contact

Address: 3281 E Guasti Rd
Ontario, CA 91761, United States
Phone: (601) 213-4426
Email: info@benchchem.com