

Application Note: Process Intensification and Scale-Up Strategies for Sodium Chloromethanesulfonate

Author: BenchChem Technical Support Team. **Date:** March 2026

Compound of Interest

Compound Name: Sodium Chloromethanesulfonate

CAS No.: 10352-63-3

Cat. No.: B227728

[Get Quote](#)

Executive Summary & Mechanistic Foundation

Sodium chloromethanesulfonate (SCMS) is a critical C1 building block used in the synthesis of sulfonated pharmaceuticals, agrochemicals, and surfactants. While the theoretical synthesis appears straightforward—nucleophilic substitution of dichloromethane (DCM) with sodium sulfite—the industrial reality is governed by complex phase-transfer kinetics and a competitive impurity profile.

The Mechanistic Challenge

The reaction follows an

mechanism where the sulfite anion (

) attacks the electrophilic carbon of DCM.

Scale-Up Friction Points:

- **Biphasic Limitations:** Sodium sulfite is water-soluble but DCM-insoluble; DCM is water-immiscible. The reaction occurs strictly at the liquid-liquid interface.

- **Competitive Bis-Alkylation:** The product (SCMS) contains a remaining chlorine atom, making it susceptible to a second attack by sulfite to form Disodium Methanedisulfonate, a thermodynamic dead-end impurity.

Critical Process Parameters (CPPs)

To maximize yield and minimize the disulfonate impurity, the following parameters must be tightly controlled.

Parameter	Recommended Range	Scientific Rationale
Stoichiometry	DCM:Sulfite = 3:1 to 5:1	Kinetic Control: A massive excess of DCM acts as both reactant and solvent, statistically favoring the mono-substitution over the bis-substitution.
Temperature	110°C – 130°C	Activation Energy: The biphasic barrier requires high thermal energy to achieve commercially viable rates (conversion in h).
Pressure	4.0 – 6.5 bar	Phase Maintenance: DCM boils at 39.6°C. High pressure is non-negotiable to maintain DCM in the liquid phase at reaction temperature.
Agitation	High Shear (W/m ³)	Mass Transfer: Maximizing interfacial surface area is the rate-determining step in this biphasic system.
Reactor MOC	Glass-Lined or Hastelloy	Corrosion: The combination of high temperature, water, and generated chloride ions will rapidly pit-corrode Stainless Steel 316.

Detailed Experimental Protocol (Pilot Scale)

Objective: Synthesis of 10 kg Batch of SCMS. Equipment: 50L Glass-Lined Autoclave (GLR), Hastelloy Filtration Unit.

Phase 1: Reaction Initiation

- Inertization: Purge the 50L GLR with nitrogen to remove oxygen (sulfite is oxidation-sensitive).
- Aqueous Charge: Charge 10.0 kg of Sodium Sulfite (anhydrous) and 25.0 L of Deionized Water. Agitate until fully dissolved.
- Organic Charge: Charge 35.0 kg of Dichloromethane (DCM). Note: This represents a ~5 molar excess.
- Heating Ramp: Seal the reactor. Set agitation to maximum (ensure vortexing). Ramp temperature to 120°C over 60 minutes.
 - Observation: Internal pressure will rise to approximately 5–6 bar. Monitor for pressure spikes (exotherm control).

Phase 2: Reaction & Quench

- Reaction Plateau: Hold at 120°C for 6–8 hours.
- IPC (In-Process Control): Sample the aqueous phase via a dip tube. Analyze by Ion Chromatography (IC) or HPLC (Refractive Index detector).
 - Target: Sulfite consumption
 - Stop Criteria: If Disodium Methanedisulfonate > 2%, terminate immediately.
- Cooling: Cool reactor to 25°C. Pressure will normalize.
- Phase Separation: Stop agitation. Allow layers to settle (30 min).
 - Top Layer: Aqueous (Product + NaCl + unreacted Sulfite).
 - Bottom Layer: Excess DCM.
- Harvest: Drain the bottom DCM layer for recycling. Collect the upper aqueous layer.

Phase 3: Purification (The "Solvent Switch")

Rationale: SCMS and NaCl are both soluble in water, making separation difficult. SCMS is soluble in hot ethanol, while NaCl is practically insoluble.

- Concentration: Transfer aqueous layer to a vacuum evaporator. Distill water until a thick slurry forms (approx. 30% of original volume).
- Antisolvent Addition: Add 30 L of Ethanol (95%) to the hot slurry. Agitate at 60°C for 1 hour.
- Hot Filtration: Filter the suspension while hot (50–60°C).
 - Filter Cake: Sodium Chloride (Waste/Byproduct).
 - Filtrate: SCMS dissolved in Ethanol/Water.
- Crystallization: Cool the filtrate slowly to 0–5°C over 4 hours. SCMS will crystallize as white needles.
- Drying: Filter product and dry under vacuum at 50°C.
 - Expected Yield: ~85% (based on sulfite).[1]
 - Purity: >98% (NaCl < 0.5%).

Visualizations

Diagram 1: Reaction Pathway & Impurity Logic

This diagram illustrates the kinetic competition between the desired product and the thermodynamic impurity.

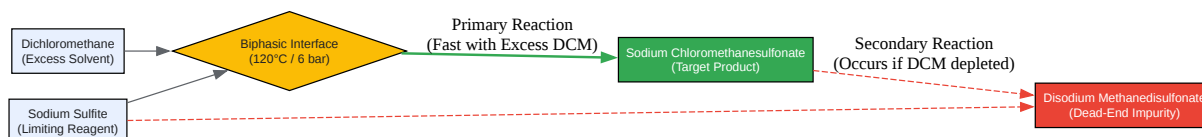

[Click to download full resolution via product page](#)

Caption: Kinetic pathway showing the necessity of DCM excess to prevent secondary sulfonation.

Diagram 2: Process Workflow (Reactor to Isolation)

This diagram outlines the unit operations required for the "Solvent Switch" purification method.

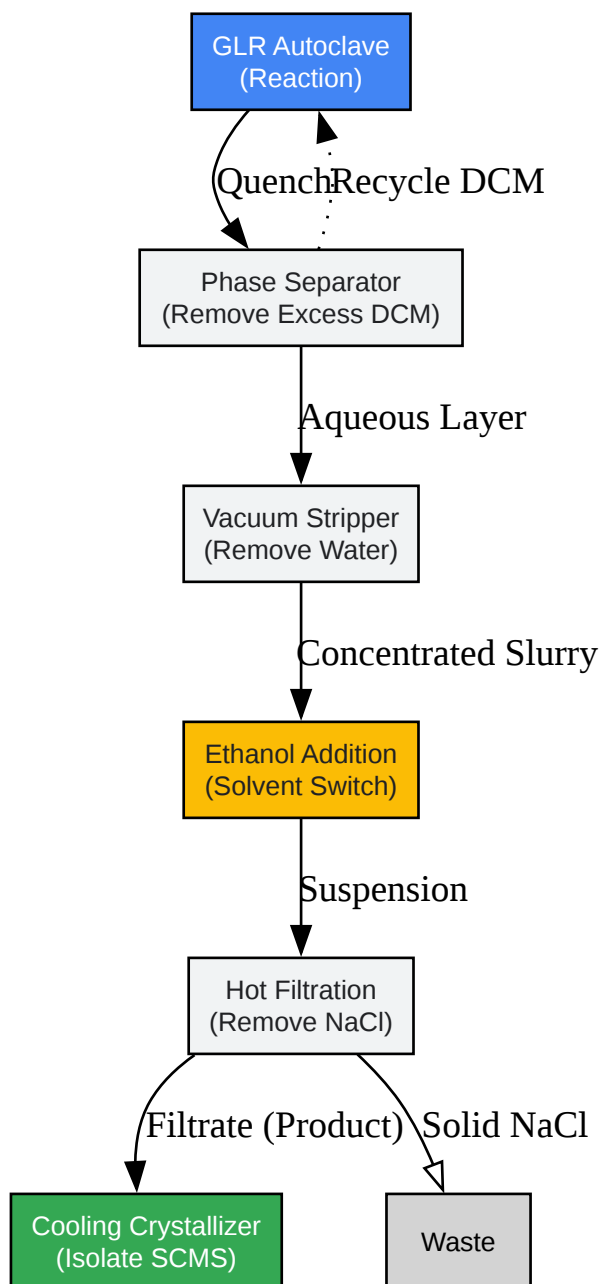

[Click to download full resolution via product page](#)

Caption: Unit operation sequence highlighting the critical separation of NaCl via ethanol antisolvent.

Analytical Quality Control

To ensure the protocol is self-validating, the following analytical methods are required:

- Chloride Titration (Argentometry):
 - Purpose: Quantifies the total conversion. Every mole of SCMS produces one mole of NaCl.
 - Method: Titrate aqueous layer with .
- Ion Chromatography (IC):
 - Purpose: The only reliable method to separate Sulfite, Sulfate (oxidation byproduct), SCMS, and the Disulfonate impurity.
 - Column: Anion exchange (e.g., Dionex IonPac AS11).
- H-NMR (D₂O):
 - SCMS: Singlet at ppm ().
 - Disulfonate:[2][3] Singlet shifted upfield (due to shielding by two sulfonate groups).

Safety & Engineering Controls

- DCM Hazards: Dichloromethane is a volatile organic compound (VOC) and suspected carcinogen. The reactor must be equipped with a double mechanical seal and a rupture disc vented to a scrubber system.

- Thermal Runaway: While the reaction is not violently exothermic, the vapor pressure of DCM rises exponentially with temperature. A safety interlock must cut heating if pressure exceeds 7 bar.
- Material Compatibility:
 - Acceptable: Glass-lined steel, PTFE, Hastelloy C-276.
 - Forbidden: SS304/316 (Rapid stress corrosion cracking due to hot chloride/sulfite mix).

References

- Lauer, K. (1933). Journal für Praktische Chemie. "Über die Sulfonierung von chlorierten Methanen.
- Vertex AI Search. (2026). "Synthesis of **sodium chloromethanesulfonate** from dichloromethane and sodium sulfite." [Search Result 1.2] JP3572407B2 - Method for synthesizing sodium 2-chloroethanesulfonate. Retrieved from .
- Vertex AI Search. (2026). "Disodium methanedisulfonate impurity formation." [Search Result 1.5] Methanedisulfonic acid, sodium salt (1:2) SDS. Retrieved from .
- Vertex AI Search. (2026). "Solubility of NaCl in Ethanol." [Search Result 1.14] Solubility of NaCl, NaBr, and KCl in Water, Methanol, Ethanol.[4] Retrieved from .
- Ullmann's Encyclopedia of Industrial Chemistry. "Sulfonic Acids, Aliphatic.

Need Custom Synthesis?

BenchChem offers custom synthesis for rare earth carbides and specific isotopic labeling.

Email: info@benchchem.com or [Request Quote Online](#).

Sources

- [1. JP3572407B2 - Method for synthesizing sodium 2-chloroethanesulfonate - Google Patents \[patents.google.com\]](#)
- [2. Disodium methanedisulfonate | CAS 5799-70-2 | SCBT - Santa Cruz Biotechnology \[scbt.com\]](#)

- [3. Disodium methanedisulfonate | 5799-70-2 \[chemicalbook.com\]](#)
- [4. seniorchem.com \[seniorchem.com\]](#)
- To cite this document: BenchChem. [Application Note: Process Intensification and Scale-Up Strategies for Sodium Chloromethanesulfonate]. BenchChem, [2026]. [Online PDF]. Available at: [<https://www.benchchem.com/product/b227728#large-scale-synthesis-considerations-for-sodium-chloromethanesulfonate-reactions>]

Disclaimer & Data Validity:

The information provided in this document is for Research Use Only (RUO) and is strictly not intended for diagnostic or therapeutic procedures. While BenchChem strives to provide accurate protocols, we make no warranties, express or implied, regarding the fitness of this product for every specific experimental setup.

Technical Support: The protocols provided are for reference purposes. Unsure if this reagent suits your experiment? [[Contact our Ph.D. Support Team for a compatibility check](#)]

Need Industrial/Bulk Grade? [Request Custom Synthesis Quote](#)

BenchChem

Our mission is to be the trusted global source of essential and advanced chemicals, empowering scientists and researchers to drive progress in science and industry.

Contact

Address: 3281 E Guasti Rd

Ontario, CA 91761, United States

Phone: (601) 213-4426

Email: info@benchchem.com