

Technical Support Center: Mastering Temperature Control in Exothermic Alkyne Functionalization

Author: BenchChem Technical Support Team. **Date:** April 2026

Compound of Interest

Compound Name: 2-(But-3-yn-1-yloxy)pyrimidine

CAS No.: 111097-47-3

Cat. No.: B022262

[Get Quote](#)

Welcome to the Technical Support Center for exothermic alkyne functionalization. This resource is designed for researchers, scientists, and drug development professionals who are navigating the challenges of managing heat release in these powerful and versatile reactions. This guide moves beyond simple step-by-step instructions to provide a deeper understanding of the "why" behind temperature control, empowering you to troubleshoot effectively and ensure the safety, selectivity, and scalability of your reactions.

Part 1: Frequently Asked Questions (FAQs)

This section addresses common questions about temperature control in exothermic alkyne functionalization.

Q1: Why is temperature control so critical in alkyne functionalization reactions?

A1: Many common and synthetically valuable alkyne functionalizations, such as the Copper(I)-catalyzed Azide-Alkyne Cycloaddition (CuAAC) or "click chemistry," are highly exothermic.^{[1][2]} An exothermic reaction releases heat, which can increase the reaction rate. This, in turn,

generates more heat, creating a positive feedback loop that can lead to a dangerous situation known as a thermal runaway if not properly managed.[3][4][5]

Inadequate temperature control can lead to:

- Safety Hazards: Uncontrolled exotherms can cause rapid pressure buildup, solvent boiling, and even explosions.[4][6][7]
- Reduced Selectivity: Many reactions can proceed through different pathways depending on the temperature.[8][9] Elevated temperatures can favor the formation of undesired side products, such as homocoupled (Glaser) products, complicating purification and reducing the yield of the desired product.[10]
- Catalyst Decomposition: Catalysts can be sensitive to high temperatures, leading to deactivation and a stalled reaction.[10]
- Product Degradation: The desired product itself may not be stable at elevated temperatures. [10]

Q2: Which alkyne functionalization reactions are known to be significantly exothermic?

A2: Several widely used alkyne functionalization reactions are known for their exothermic nature:

- Copper(I)-catalyzed Azide-Alkyne Cycloaddition (CuAAC): This reaction is highly exothermic, with a reaction enthalpy (ΔH) reported to be between -50 and -65 kcal/mol.[1] While it has a high activation barrier in the absence of a catalyst, the copper catalyst dramatically lowers this barrier, allowing the reaction to proceed rapidly at room temperature with significant heat evolution.[1][2]
- Sonogashira Coupling: This palladium and copper co-catalyzed cross-coupling of terminal alkynes with aryl or vinyl halides is also known to be exothermic.[11][12][13][14] The overall thermodynamic profile favors product formation, and careful heat management is necessary, especially during scale-up.[10][11]
- C-H Functionalization of Alkynes: Certain C-H activation/functionalization reactions involving alkynes can also be exothermic, depending on the specific reagents and conditions

employed.^[15]

Q3: What are the initial signs of a loss of temperature control?

A3: Vigilant monitoring is key to early detection. Look for:

- A rapid, unexpected rise in the internal reaction temperature that outpaces the cooling system's ability to compensate.^[4]
- A sudden increase in pressure within the reaction vessel.
- A noticeable change in the reaction mixture's color or viscosity.
- An increase in the rate of gas evolution.^[3]
- Solvent refluxing at the condenser, even if the external bath temperature is well below the solvent's boiling point.

Q4: How does reaction scale-up affect temperature control?

A4: Scaling up a reaction presents significant challenges for temperature control. The volume of the reaction mixture increases by the cube of the vessel's radius, while the heat transfer area (the surface of the reactor in contact with the cooling medium) only increases by the square of the radius.^{[16][17]} This means that the ability to remove heat does not keep pace with the rate of heat generation, making thermal runaway a much greater risk at larger scales.^{[16][18]} What may be a manageable temperature increase on a millimole scale can become a serious safety hazard at the kilogram scale.^{[10][16]}

Part 2: Troubleshooting Guide

This section provides a more in-depth look at specific problems, their root causes, and actionable solutions.

Issue 1: The reaction temperature is consistently overshooting the setpoint.

- Possible Cause 1: Inadequate Cooling Capacity. The cooling system may not be sufficient for the scale and exothermicity of the reaction.

- Solution:
 - Lower the Coolant Temperature: Use a colder cooling bath.[\[19\]](#) See the table below for common laboratory cooling baths.
 - Increase Coolant Flow Rate: Ensure the coolant is circulating efficiently through the reactor jacket or cooling coils.
 - Improve Heat Transfer: Ensure good thermal contact between the reaction flask and the cooling bath. For larger vessels, consider using a jacketed reactor or internal cooling coils.[\[20\]](#)

Cooling Bath Composition	Approximate Temperature (°C)
Ice/Water	0
Ice/Saturated NaCl	-20
Dry Ice/Acetone or Isopropanol	-78
Liquid Nitrogen	-196

- Possible Cause 2: Reagent Addition Rate is Too Fast. Adding a reactive component too quickly can generate heat faster than the cooling system can remove it.[\[3\]](#)
 - Solution:
 - Slow, Controlled Addition: Use an addition funnel or a syringe pump to add the limiting reagent slowly and dropwise.[\[3\]](#)
 - Monitor Temperature During Addition: Continuously monitor the internal reaction temperature and pause the addition if it rises too quickly.[\[3\]](#)
- Possible Cause 3: Poor Mixing. Inadequate stirring can lead to localized "hot spots" where the reaction is proceeding much faster than in the bulk solution.[\[21\]](#)
 - Solution:

- Increase Stirring Rate: Ensure vigorous and efficient stirring to maintain a homogenous temperature throughout the reaction mixture.
- Optimize Stirrer Design: For larger or more viscous reactions, consider using an overhead stirrer with a properly designed impeller to ensure good mixing.[10][21]

Issue 2: The reaction is sluggish or stalls after an initial exotherm.

- Possible Cause 1: Catalyst Deactivation. The initial exotherm may have been too high, leading to the decomposition of the temperature-sensitive catalyst.[10]
 - Solution:
 - Pre-cool the Reaction Mixture: Before adding the catalyst or initiating reagent, cool the reaction mixture to a temperature below the target setpoint.
 - Portion-wise Catalyst Addition: In some cases, adding the catalyst in several small portions can help to moderate the initial exotherm.
- Possible Cause 2: Accumulation of Unreacted Starting Material. If the initial temperature is too low, the reaction may not initiate efficiently, leading to a buildup of reactants. A subsequent small temperature increase could then trigger a rapid, uncontrolled reaction of the accumulated reagents.
 - Solution:
 - Ensure Reaction Initiation: Confirm that the reaction has started (e.g., by a slight temperature increase or by TLC/LC-MS analysis) before proceeding with the bulk of the reagent addition.
 - Reaction Calorimetry: For process development, use a reaction calorimeter to determine the heat of reaction and the rate of heat evolution under different conditions. [22][23] This data is invaluable for safe scale-up.[21]

Issue 3: Formation of undesired side products, such as homocoupled diynes (Glaser coupling).

- Possible Cause: Excessive Reaction Temperature. Higher temperatures can favor side reactions. For example, in CuAAC, high temperatures can promote the oxidative homocoupling of the terminal alkyne.[\[24\]](#)
 - Solution:
 - Maintain a Lower Reaction Temperature: Operate the reaction at the lowest temperature that still provides a reasonable reaction rate. Even for reactions that are reported to run at "room temperature," active cooling may be necessary to dissipate the heat generated and maintain a constant temperature.[\[22\]](#)
 - Use a Ligand: In CuAAC, the use of a ligand can both accelerate the desired reaction and stabilize the Cu(I) oxidation state, suppressing side reactions.[\[25\]](#)

Part 3: Advanced Temperature Control Strategies

For highly exothermic reactions or large-scale processes, more advanced temperature control strategies may be necessary.

Continuous Flow Reactors

Continuous flow reactors offer significant advantages for managing exothermic reactions.[\[26\]](#) Their high surface-area-to-volume ratio allows for extremely efficient heat transfer, enabling precise temperature control that is often not possible in batch reactors.[\[27\]](#)[\[28\]](#)[\[29\]](#) This enhanced control can lead to improved safety, higher yields, and better product quality.

Heat Transfer: Flow vs. Batch

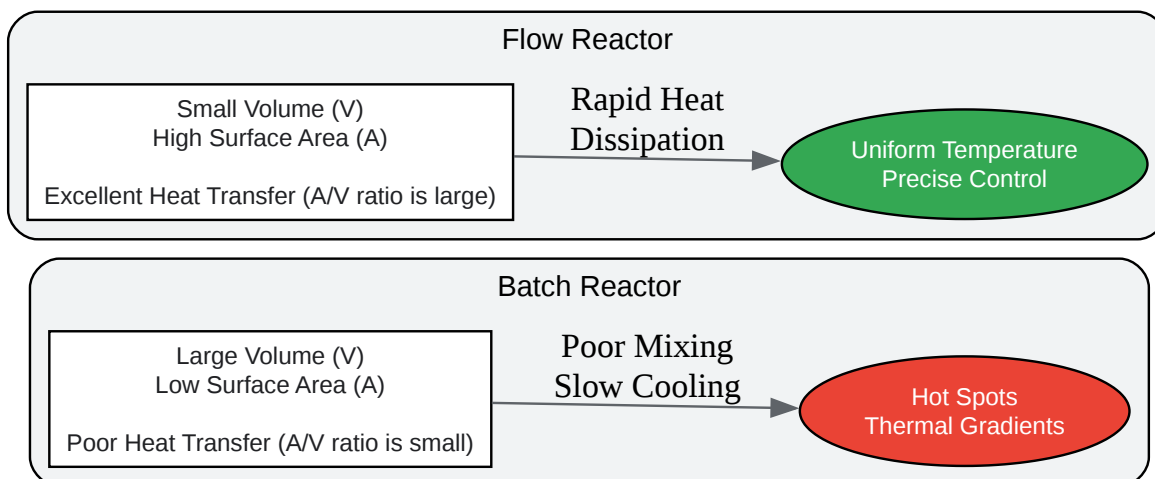

[Click to download full resolution via product page](#)

Caption: Comparison of heat transfer characteristics in batch vs. flow reactors.

Semi-Batch Operation

In a semi-batch process, one or more reactants are added continuously or in portions to the reactor over time.^[17] This allows for the rate of heat generation to be controlled by the rate of reagent addition, preventing the accumulation of large amounts of unreacted, high-energy material.^[17]

Semi-Batch Exothermic Reaction Workflow

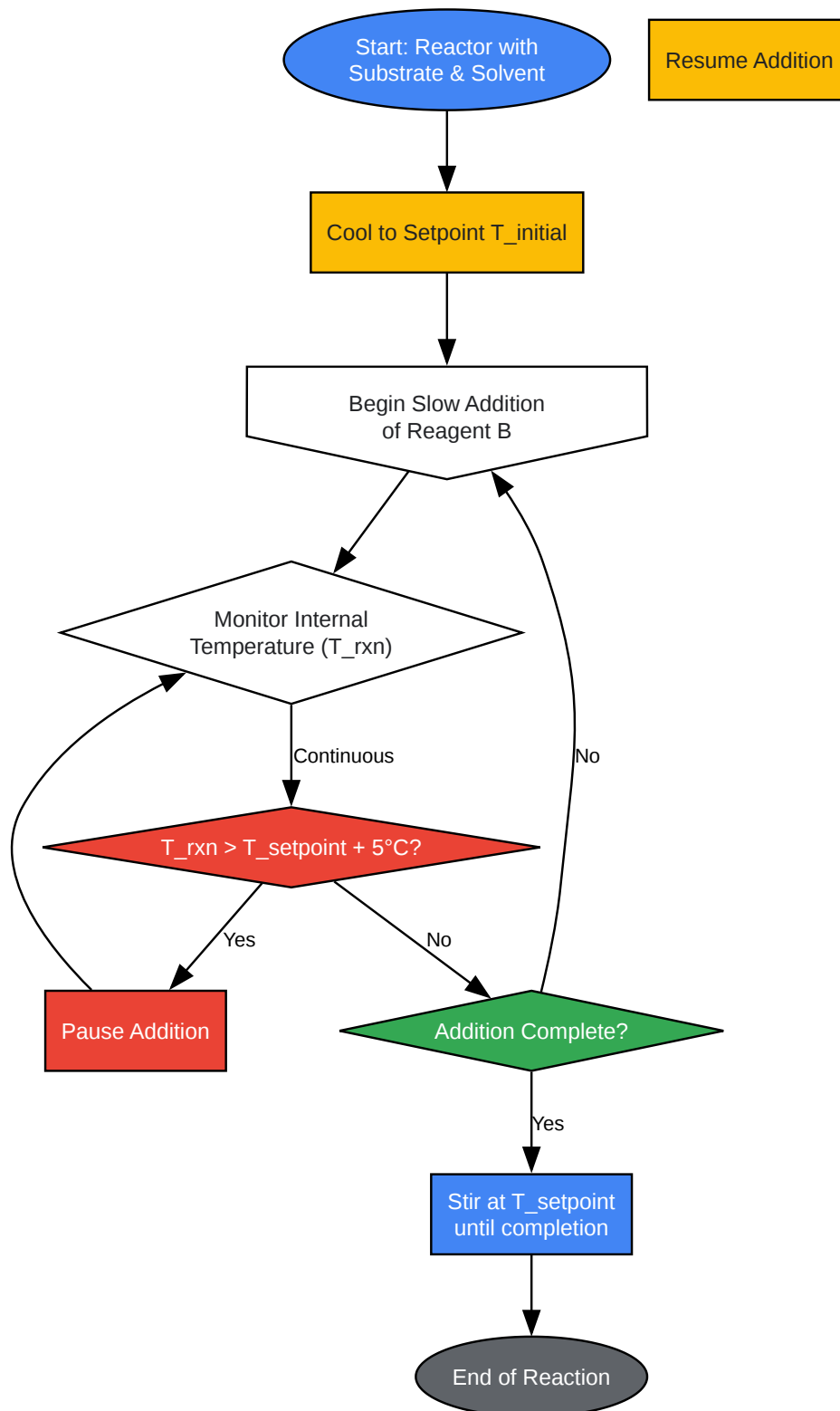

[Click to download full resolution via product page](#)

Need Custom Synthesis?

BenchChem offers custom synthesis for rare earth carbides and specific isotopic labeling.

Email: info@benchchem.com or [Request Quote Online](#).

Sources

- [1. Copper-catalyzed azide–alkyne cycloaddition \(CuAAC\) and beyond: new reactivity of copper\(i\) acetylides - PMC \[pmc.ncbi.nlm.nih.gov\]](#)
- [2. Click Chemistry \[organic-chemistry.org\]](#)
- [3. labproinc.com \[labproinc.com\]](#)
- [4. encyclopedia.che.engin.umich.edu \[encyclopedia.che.engin.umich.edu\]](#)
- [5. msclab.wordpress.com \[msclab.wordpress.com\]](#)
- [6. Exothermic Reaction Hazards - TSM TheSafetyMaster Private Limited \[thesafetymaster.com\]](#)
- [7. tuvsud.com \[tuvsud.com\]](#)
- [8. The stereo-divergent functionalization of alkynes: a comprehensive review - PMC \[pmc.ncbi.nlm.nih.gov\]](#)
- [9. The stereo-divergent functionalization of alkynes: a comprehensive review - RSC Advances \(RSC Publishing\) DOI:10.1039/D5RA01579K \[pubs.rsc.org\]](#)
- [10. pdf.benchchem.com \[pdf.benchchem.com\]](#)
- [11. Computational study of the Sonogashira cross-coupling reaction in the gas phase and in dichloromethane solution - PubMed \[pubmed.ncbi.nlm.nih.gov\]](#)
- [12. Sonogashira Coupling \[organic-chemistry.org\]](#)
- [13. Sonogashira coupling - Wikipedia \[en.wikipedia.org\]](#)
- [14. chem.libretexts.org \[chem.libretexts.org\]](#)
- [15. Room-Temperature Cu\(II\) Radical-Triggered Alkyne C–H Activation - PMC \[pmc.ncbi.nlm.nih.gov\]](#)
- [16. pubs.acs.org \[pubs.acs.org\]](#)
- [17. fauske.com \[fauske.com\]](#)

- [18. Rules of Thumb: Scale-up - Features - The Chemical Engineer \[thechemicalengineer.com\]](#)
- [19. moodle2.units.it \[moodle2.units.it\]](#)
- [20. asynt.com \[asynt.com\]](#)
- [21. amarequip.com \[amarequip.com\]](#)
- [22. benchchem.com \[benchchem.com\]](#)
- [23. chem.libretexts.org \[chem.libretexts.org\]](#)
- [24. Copper-Catalyzed Azide–Alkyne Click Chemistry for Bioconjugation - PMC \[pmc.ncbi.nlm.nih.gov\]](#)
- [25. jenabioscience.com \[jenabioscience.com\]](#)
- [26. amt.uk \[amt.uk\]](#)
- [27. Control Strategies For Managing Exothermic Reactions In Flow \[eureka.patsnap.com\]](#)
- [28. syrris.com \[syrris.com\]](#)
- [29. vapourtec.com \[vapourtec.com\]](#)
- [To cite this document: BenchChem. \[Technical Support Center: Mastering Temperature Control in Exothermic Alkyne Functionalization\]. BenchChem, \[2026\]. \[Online PDF\]. Available at: \[https://www.benchchem.com/product/b022262/docs#technical-support-center-mastering-temperature-control-in-exothermic-alkyne-functionalization\]](#)

Disclaimer & Data Validity:

The information provided in this document is for Research Use Only (RUO) and is strictly not intended for diagnostic or therapeutic procedures. While BenchChem strives to provide accurate protocols, we make no warranties, express or implied, regarding the fitness of this product for every specific experimental setup.

Technical Support: The protocols provided are for reference purposes. Unsure if this reagent suits your experiment?

Need Industrial/Bulk Grade? [Request Custom Synthesis Quote](#)

BenchChem

Our mission is to be the trusted global source of essential and advanced chemicals, empowering scientists and researchers to drive progress in science and industry.

Contact

Address: 3281 E Guasti Rd

Ontario, CA 91761, United States

Phone: (601) 213-4426

Email: info@benchchem.com

[Contact our Ph.D. Support Team for a compatibility check](#)