

# Technical Support Center: DiBAC4(3) Staining in Tissue Samples

**Author:** BenchChem Technical Support Team. **Date:** April 2026

## Compound of Interest

Compound Name:	DiBAC4(3)
CAS No.:	110425-49-5
Cat. No.:	B218353

[Get Quote](#)

This technical support center provides troubleshooting guidance and answers to frequently asked questions for researchers, scientists, and drug development professionals using the voltage-sensitive dye **DiBAC4(3)** in tissue samples. Our goal is to help you overcome challenges related to non-specific binding and achieve high-quality, reproducible results.

## Troubleshooting Guide: Non-Specific Binding and High Background

High background fluorescence can obscure the specific signal from **DiBAC4(3)**, making data interpretation difficult. Non-specific binding is a primary contributor to this issue. Below are common problems and solutions to mitigate them.

Problem	Potential Cause	Recommended Solution
High Background Fluorescence	Autofluorescence: Endogenous fluorophores within the tissue (e.g., collagen, elastin, lipofuscin) can emit fluorescence in the same spectral range as DiBAC4(3).	<ul style="list-style-type: none"> <li>- Pre-Staining Quenching: Treat tissue sections with a quenching agent like 0.1% Sudan Black B in 70% ethanol for 10-30 minutes, followed by thorough washing. -</li> <li>Photobleaching: Expose the unstained tissue section to the excitation wavelength for a period before staining to reduce autofluorescence.[1] -</li> <li>Spectral Unmixing: If your imaging system supports it, use spectral unmixing to separate the DiBAC4(3) signal from the autofluorescence spectrum.</li> </ul>
Non-Specific Binding of DiBAC4(3): As a lipophilic and anionic dye, DiBAC4(3) can non-specifically bind to intracellular proteins and membranes through hydrophobic and ionic interactions.[2][3][4][5][6]	<ul style="list-style-type: none"> <li>- Blocking: Before applying DiBAC4(3), incubate the tissue section with a blocking buffer containing proteins like Bovine Serum Albumin (BSA) or normal serum to saturate non-specific binding sites.[7] -</li> <li>Detergents: Include a low concentration of a non-ionic detergent (e.g., 0.05-0.1% Tween-20 or Triton X-100) in your washing buffers to help reduce hydrophobic interactions.</li> </ul>	
Excessive Dye Concentration: Using too high a concentration of DiBAC4(3) can lead to	- Titration: Perform a concentration titration to determine the optimal DiBAC4(3) concentration for	

increased non-specific binding and potential dye aggregation.

your specific tissue type and experimental conditions. Start with a lower concentration and incrementally increase it.

"Sparkles" or Precipitates in the Image

Dye Aggregation: DiBAC4(3) can form aggregates in aqueous solutions, which appear as bright, punctate "sparkles" in the image.[\[8\]](#)

- Fresh Working Solution: Always prepare fresh DiBAC4(3) working solutions from a DMSO stock immediately before use. - Centrifugation: Centrifuge the diluted DiBAC4(3) working solution at high speed (e.g., >10,000 x g) for 5-10 minutes to pellet any aggregates and use the supernatant for staining.[\[8\]](#) - Solubilizing Agents: Consider including a low concentration of a non-ionic surfactant like Pluronic F-127 (0.02-0.04%) in the staining buffer to improve dye solubility.[\[9\]](#)

Weak or No Signal

Low Signal-to-Noise Ratio: The specific signal from DiBAC4(3) may be weak compared to the background noise.[\[8\]](#)

- Optimize Incubation Time: Ensure sufficient incubation time for the dye to penetrate the tissue and reach equilibrium. This may need to be optimized for different tissue thicknesses. - Image Acquisition Settings: Adjust the gain and exposure settings on your microscope to enhance the signal. However, be cautious not to saturate the detector.

---

Photobleaching: The fluorescent signal of DiBAC4(3) can diminish upon prolonged exposure to excitation light.[8]

- Minimize Light Exposure: Keep the stained samples protected from light as much as possible. - Antifade Mounting Media: Use an antifade mounting medium to preserve the fluorescence signal. - Efficient Imaging: Locate the region of interest using lower light intensity or a different channel before capturing the final image with the appropriate settings.[8]

---

## Frequently Asked Questions (FAQs)

Q1: What is the mechanism of **DiBAC4(3)** and how does it lead to non-specific binding?

A1: **DiBAC4(3)** is an anionic, lipophilic fluorescent dye that is sensitive to changes in membrane potential. In depolarized cells, the relatively positive intracellular environment facilitates the entry of the negatively charged **DiBAC4(3)**. Once inside, it binds to intracellular proteins and membranes, which enhances its fluorescence.[2][3][5][6] This binding to intracellular components is the primary source of non-specific signal, as the dye is not exclusively localized to the plasma membrane.

Q2: Can I use **DiBAC4(3)** on fixed tissue samples?

A2: Yes, **DiBAC4(3)** can be used on fixed tissue samples. However, fixation can alter cell membranes and intracellular structures, potentially increasing non-specific binding.[4] It is crucial to optimize the fixation protocol and include appropriate blocking steps to minimize background fluorescence.

Q3: What is a good starting concentration for **DiBAC4(3)** in tissue staining?

A3: For whole organisms, a concentration of 0.95  $\mu\text{M}$  has been suggested.[8][10] For tissue sections, it is recommended to start with a concentration in the range of 1-5  $\mu\text{M}$  and then

perform a titration to find the optimal concentration for your specific application.[9]

Q4: How long should I incubate my tissue with **DiBAC4(3)**?

A4: Incubation times can vary depending on the tissue type, thickness, and fixation method. A typical starting point is 15-30 minutes at room temperature or 37°C.[9] It is important to optimize the incubation time to allow for adequate tissue penetration without excessive non-specific binding.

Q5: What blocking agents are recommended for reducing non-specific **DiBAC4(3)** binding?

A5: While protocols specifically for **DiBAC4(3)** in tissues are not abundant, principles from immunofluorescence suggest that blocking with protein-based solutions can be effective. Using a buffer containing 1-5% BSA or 5-10% normal serum from a species different from your primary antibody (if used in co-staining) can help block non-specific hydrophobic and ionic interactions.[7]

## Quantitative Data Summary

The following table summarizes key quantitative parameters for the use of **DiBAC4(3)**.

Parameter	Value	Reference
Excitation Wavelength (max)	~493 nm	[11]
Emission Wavelength (max)	~516 nm	[11]
Stock Solution Concentration (in DMSO)	1.9 mM (1 mg/mL)	[8][10]
Working Concentration (Cell Culture)	47.5 µM	[8][10]
Working Concentration (Whole Organisms)	0.95 µM	[8][10]
Recommended Starting Concentration (Tissues)	1 - 5 µM	[9]
Typical Incubation Time	15 - 60 minutes	[8][9]

## Experimental Protocols

### Protocol 1: DiBAC4(3) Staining of Frozen Tissue Sections

- Tissue Preparation:
  - Cut frozen tissue sections at 5-15  $\mu\text{m}$  thickness using a cryostat and mount them on charged slides.
  - Allow the sections to air dry for 30-60 minutes at room temperature.
- Fixation (Optional but Recommended):
  - Fix the sections with 4% paraformaldehyde (PFA) in PBS for 15 minutes at room temperature.
  - Wash three times with PBS for 5 minutes each.
- Blocking:
  - Incubate sections with a blocking buffer (e.g., PBS with 5% BSA and 0.1% Triton X-100) for 1 hour at room temperature in a humidified chamber.
- **DiBAC4(3)** Staining:
  - Prepare a fresh working solution of **DiBAC4(3)** in a suitable buffer (e.g., PBS or HBSS) to the desired concentration (start with 2  $\mu\text{M}$ ).
  - Centrifuge the working solution at  $>10,000 \times g$  for 5 minutes to remove aggregates.
  - Apply the supernatant to the tissue sections and incubate for 15-30 minutes at room temperature, protected from light.
- Washing:
  - Wash the sections three times with PBS containing 0.1% Triton X-100 for 5 minutes each to remove unbound dye.

- Mounting and Imaging:
  - Mount the coverslip using an antifade mounting medium.
  - Image the sections using a fluorescence microscope with appropriate filters for **DiBAC4(3)** (Excitation/Emission: ~493/516 nm).

## Protocol 2: DiBAC4(3) Staining of Paraffin-Embedded Tissue Sections

- Deparaffinization and Rehydration:
  - Immerse slides in xylene (or a xylene substitute) two times for 5 minutes each.
  - Rehydrate through a graded series of ethanol (100%, 95%, 70%, 50%) for 3 minutes each.
  - Rinse with distilled water.
- Antigen Retrieval (Optional, for co-staining):
  - If co-staining with antibodies, perform antigen retrieval as required for the specific antibody.
- Blocking:
  - Follow the blocking procedure as described in Protocol 1, step 3.
- **DiBAC4(3)** Staining:
  - Follow the staining procedure as described in Protocol 1, step 4.
- Washing:
  - Follow the washing procedure as described in Protocol 1, step 5.
- Mounting and Imaging:

- Follow the mounting and imaging procedure as described in Protocol 1, step 6.

## Visualizations

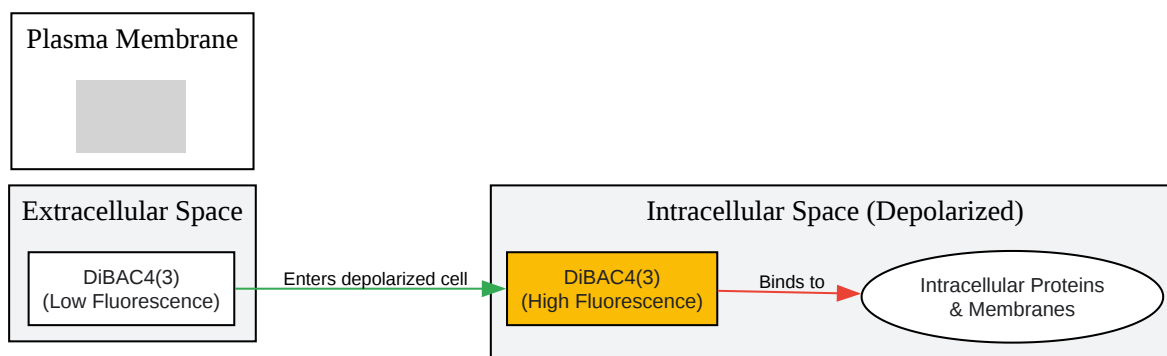

[Click to download full resolution via product page](#)

Caption: Mechanism of **DiBAC4(3)** fluorescence upon cell depolarization.

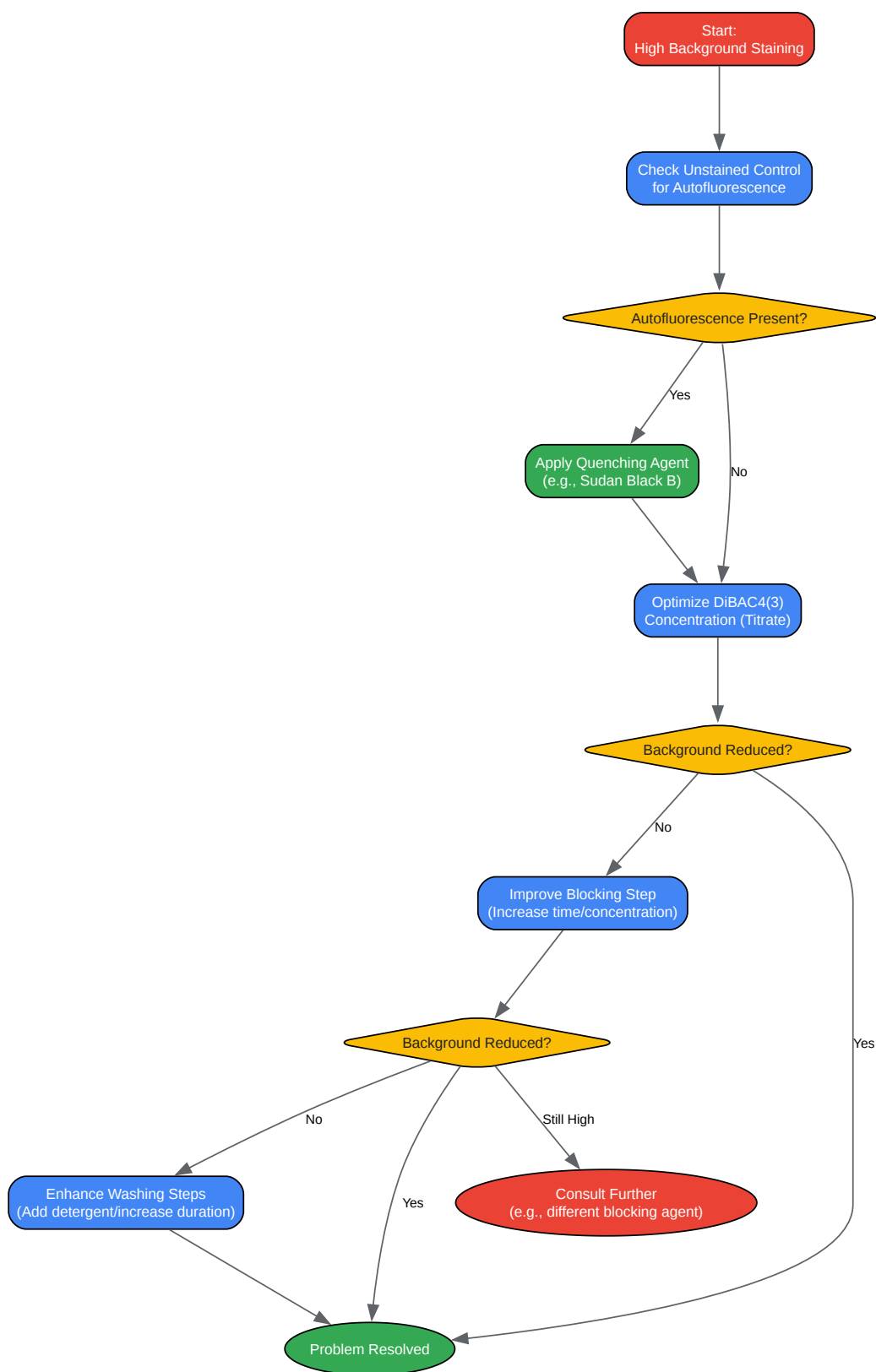

[Click to download full resolution via product page](#)

Caption: Logical workflow for troubleshooting high background staining with **DiBAC4(3)**.

### Need Custom Synthesis?

BenchChem offers custom synthesis for rare earth carbides and specific isotopic labeling.

Email: [info@benchchem.com](mailto:info@benchchem.com) or [Request Quote Online](#).

## References

- 1. Simple Elimination of Background Fluorescence in Formalin-Fixed Human Brain Tissue for Immunofluorescence Microscopy - PMC [[pmc.ncbi.nlm.nih.gov](https://pubmed.ncbi.nlm.nih.gov)]
- 2. [interchim.fr](https://interchim.fr) [[interchim.fr](https://interchim.fr)]
- 3. Slow-Response Probes—Section 22.3 | Thermo Fisher Scientific - SG [[thermofisher.com](https://thermofisher.com)]
- 4. Methodological aspects of measuring absolute values of membrane potential in human cells by flow cytometry - PubMed [[pubmed.ncbi.nlm.nih.gov](https://pubmed.ncbi.nlm.nih.gov)]
- 5. DiBAC4(3) (Bis-(1,3-Dibutylbarbituric Acid)Trimethine Oxonol) 25 mg | Contact Us | Invitrogen™ [[thermofisher.com](https://thermofisher.com)]
- 6. [researchgate.net](https://researchgate.net) [[researchgate.net](https://researchgate.net)]
- 7. [biotium.com](https://biotium.com) [[biotium.com](https://biotium.com)]
- 8. Measuring Resting Membrane Potential Using the Fluorescent Voltage Reporters DiBAC4(3) and CC2-DMPE - PMC [[pmc.ncbi.nlm.nih.gov](https://pubmed.ncbi.nlm.nih.gov)]
- 9. [file.medchemexpress.com](https://file.medchemexpress.com) [[file.medchemexpress.com](https://file.medchemexpress.com)]
- 10. [scispace.com](https://scispace.com) [[scispace.com](https://scispace.com)]
- 11. [biotium.com](https://biotium.com) [[biotium.com](https://biotium.com)]
- To cite this document: BenchChem. [Technical Support Center: DiBAC4(3) Staining in Tissue Samples]. BenchChem, [2026]. [Online PDF]. Available at: [<https://www.benchchem.com/product/b218353/docs#technical-support-center-dibac4-3-staining-in-tissue-samples>]

---

### Disclaimer & Data Validity:

The information provided in this document is for Research Use Only (RUO) and is strictly not intended for diagnostic or therapeutic procedures. While BenchChem strives to provide accurate protocols, we make no warranties, express or implied, regarding the fitness of this product for every specific experimental setup.

**Technical Support:** The protocols provided are for reference purposes. Unsure if this reagent suits your experiment?

**Need Industrial/Bulk Grade?** [Request Custom Synthesis Quote](#)

## BenchChem

Our mission is to be the trusted global source of essential and advanced chemicals, empowering scientists and researchers to drive progress in science and industry.

### Contact

Address: 3281 E Guasti Rd  
Ontario, CA 91761, United States  
Phone: (601) 213-4426  
Email: [info@benchchem.com](mailto:info@benchchem.com)

[Contact our Ph.D. Support Team for a compatibility check](#)