

Application Notes and Protocols for the Quantification of 22-Hydroxyvitamin D3

Author: BenchChem Technical Support Team. **Date:** April 2026

Compound of Interest

Compound Name: 22-Hydroxyvitamin D3

CAS No.: 110927-46-3

Cat. No.: B217047

[Get Quote](#)

Introduction

22-Hydroxyvitamin D3 (22(OH)D3) is a metabolite of Vitamin D3, produced through the action of the cytochrome P450 enzyme CYP11A1 (also known as P450scc). While not as extensively studied as other Vitamin D metabolites like 25-hydroxyvitamin D3 or 1,25-dihydroxyvitamin D3, 22(OH)D3 has demonstrated biological activity. It has been shown to interact with the Vitamin D Receptor (VDR), suggesting a role in the regulation of gene expression.[1] The quantification of 22(OH)D3 in biological matrices is crucial for understanding its metabolic pathway, physiological relevance, and potential as a biomarker or therapeutic agent.

This document provides a detailed protocol for the quantification of **22-Hydroxyvitamin D3** using Liquid Chromatography-Tandem Mass Spectrometry (LC-MS/MS), a highly sensitive and specific method for this application.[2][3]

Physicochemical Properties of 22-Hydroxyvitamin D3

A summary of the key physicochemical properties of **22-Hydroxyvitamin D3** is presented in the table below. These properties are essential for developing appropriate extraction and chromatographic methods.

Property	Value	Notes
Molecular Formula	C ₂₇ H ₄₄ O ₂	
Molecular Weight	400.64 g/mol	
LogP (Predicted)	5.0 - 6.0	Indicates high lipophilicity, similar to other vitamin D metabolites.
Aqueous Solubility (Predicted)	Low	Expected to be poorly soluble in water, necessitating organic solvents for extraction.[4]
UV max (in Ethanol)	~264 nm	Characteristic of the cis-triene system in vitamin D compounds.

Analytical Standard

As of late 2025, a certified reference material for **22-Hydroxyvitamin D3** is not widely commercially available. Therefore, researchers may need to synthesize or custom-order this standard. The synthesis can be achieved through various organic chemistry routes, often starting from a suitable steroidal precursor.

Characterization of the Analytical Standard

Upon synthesis, the identity and purity of the **22-Hydroxyvitamin D3** standard must be rigorously confirmed.

Characterization Method	Purpose	Expected Outcome
^1H and ^{13}C NMR	Structural confirmation	Spectra should be consistent with the proposed structure of 22-Hydroxyvitamin D3.
High-Resolution Mass Spectrometry (HRMS)	Determination of elemental composition	The measured mass should be within 5 ppm of the theoretical mass.
HPLC-UV	Purity assessment	Purity should be >98%.
Extinction Coefficient	Concentration determination	An extinction coefficient, such as $18,000 \text{ M}^{-1} \text{ cm}^{-1}$ at 263 nm, can be used for accurate concentration measurement.

Experimental Protocols

The following protocols are based on established methods for the quantification of other dihydroxy-vitamin D metabolites and are adapted for **22-Hydroxyvitamin D3**.

Internal Standard

For accurate quantification by LC-MS/MS, a stable isotope-labeled internal standard, such as deuterated **22-Hydroxyvitamin D3** (e.g., **22-Hydroxyvitamin D3-d3** or -d6), is essential to correct for matrix effects and variations in sample processing.[5][6] The synthesis of such a standard would involve introducing deuterium atoms at a non-exchangeable position on the molecule.

Sample Preparation: Liquid-Liquid Extraction (LLE) from Human Serum

- Aliquoting: To a 1.5 mL microcentrifuge tube, add 200 μL of human serum.
- Internal Standard Spiking: Add 20 μL of the working internal standard solution (e.g., 50 ng/mL of deuterated **22-Hydroxyvitamin D3** in methanol).

- Protein Precipitation: Add 400 μ L of acetonitrile. Vortex vigorously for 30 seconds to precipitate proteins.
- Centrifugation: Centrifuge at 10,000 x g for 10 minutes at 4°C.
- Supernatant Transfer: Carefully transfer the supernatant to a clean tube.
- Liquid-Liquid Extraction: Add 1 mL of a hexane:ethyl acetate (9:1, v/v) mixture. Vortex for 1 minute.
- Phase Separation: Centrifuge at 3,000 x g for 5 minutes.
- Drying: Transfer the upper organic layer to a new tube and evaporate to dryness under a gentle stream of nitrogen at 40°C.
- Reconstitution: Reconstitute the dried extract in 100 μ L of the initial mobile phase (e.g., 50:50 methanol:water with 0.1% formic acid).

LC-MS/MS Method

The following table outlines the proposed parameters for the LC-MS/MS analysis.

Parameter	Recommended Setting
LC System	UPLC or HPLC system
Column	C18 reversed-phase column (e.g., 2.1 x 100 mm, 1.8 μ m)
Mobile Phase A	Water with 0.1% formic acid
Mobile Phase B	Methanol with 0.1% formic acid
Gradient	50% B to 95% B over 5 minutes, hold at 95% B for 2 minutes, return to 50% B and equilibrate for 3 minutes.
Flow Rate	0.3 mL/min
Column Temperature	40°C
Injection Volume	10 μ L
MS System	Triple quadrupole mass spectrometer
Ionization Mode	Electrospray Ionization (ESI) Positive or Atmospheric Pressure Chemical Ionization (APCI) Positive
Ion Source Temp.	150°C
Desolvation Temp.	500°C

Hypothetical MRM Transitions

The following are predicted Multiple Reaction Monitoring (MRM) transitions for **22-Hydroxyvitamin D3** and a hypothetical deuterated internal standard. These would need to be optimized empirically.

Compound	Precursor Ion (m/z)	Product Ion (m/z)	Collision Energy (eV)
22-Hydroxyvitamin D3	401.3 (M+H-H ₂ O) ⁺	383.3 (M+H-2H ₂ O) ⁺	15
401.3 (M+H-H ₂ O) ⁺	251.2 (Side chain cleavage)	25	
22-Hydroxyvitamin D3-d3 (IS)	404.3 (M+H-H ₂ O) ⁺	386.3 (M+H-2H ₂ O) ⁺	15
404.3 (M+H-H ₂ O) ⁺	251.2 (Side chain cleavage)	25	

Method Validation (Representative Data)

A full method validation should be performed according to regulatory guidelines. The following table presents hypothetical but expected performance data for the described method.

Validation Parameter	Result	Acceptance Criteria
Linearity Range	0.1 - 50 ng/mL	$r^2 > 0.99$
Lower Limit of Quantification (LLOQ)	0.1 ng/mL	S/N > 10, Accuracy within $\pm 20\%$, Precision < 20%
Accuracy (% Bias)	-5.8% to +7.2%	Within $\pm 15\%$ ($\pm 20\%$ at LLOQ)
Precision (%CV)	Intra-day: < 8%, Inter-day: < 11%	< 15% (< 20% at LLOQ)
Recovery	85 - 95%	Consistent and reproducible
Matrix Effect	92 - 103%	Within acceptable range

Visualizations

Vitamin D3 Metabolism to 22-Hydroxyvitamin D3

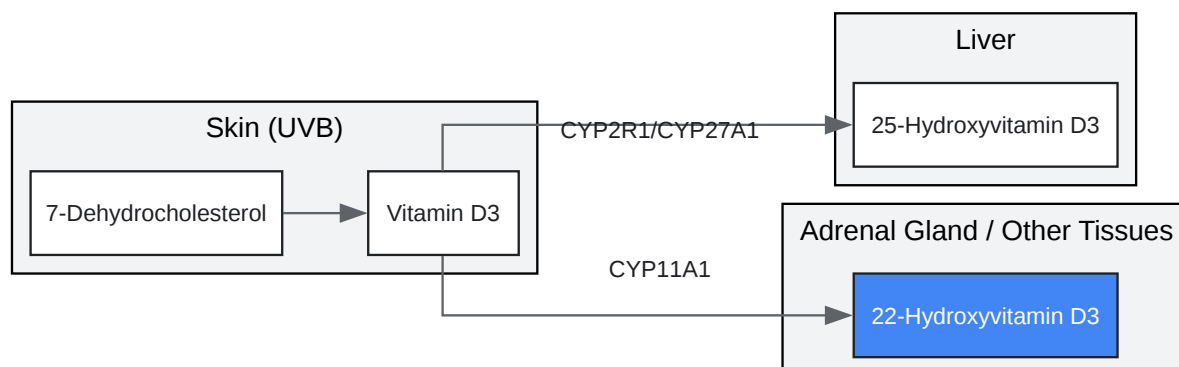

[Click to download full resolution via product page](#)

Caption: Metabolic pathway of Vitamin D3 to **22-Hydroxyvitamin D3**.

LC-MS/MS Workflow for 22(OH)D3 Quantification

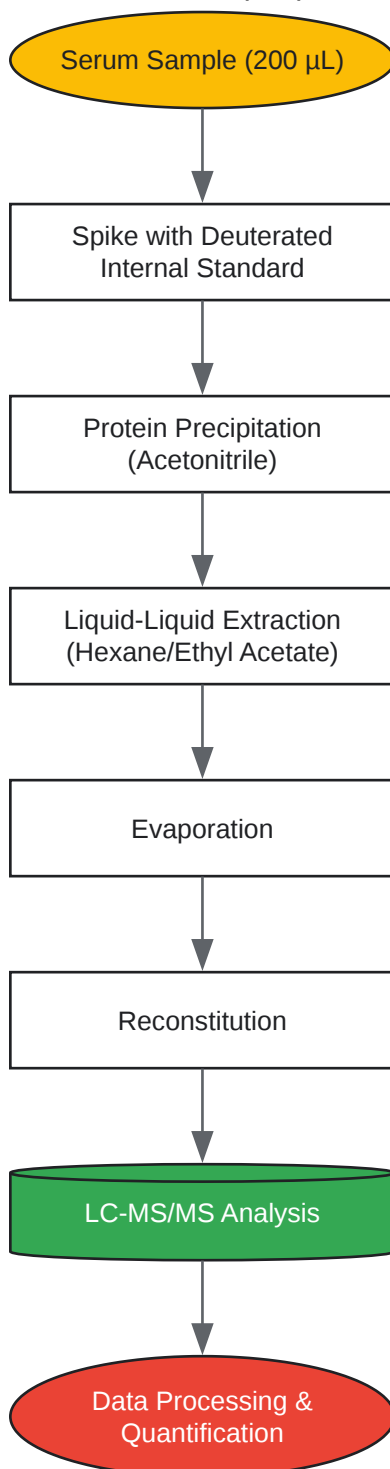

22(OH)D3 Signaling via Vitamin D Receptor (VDR)

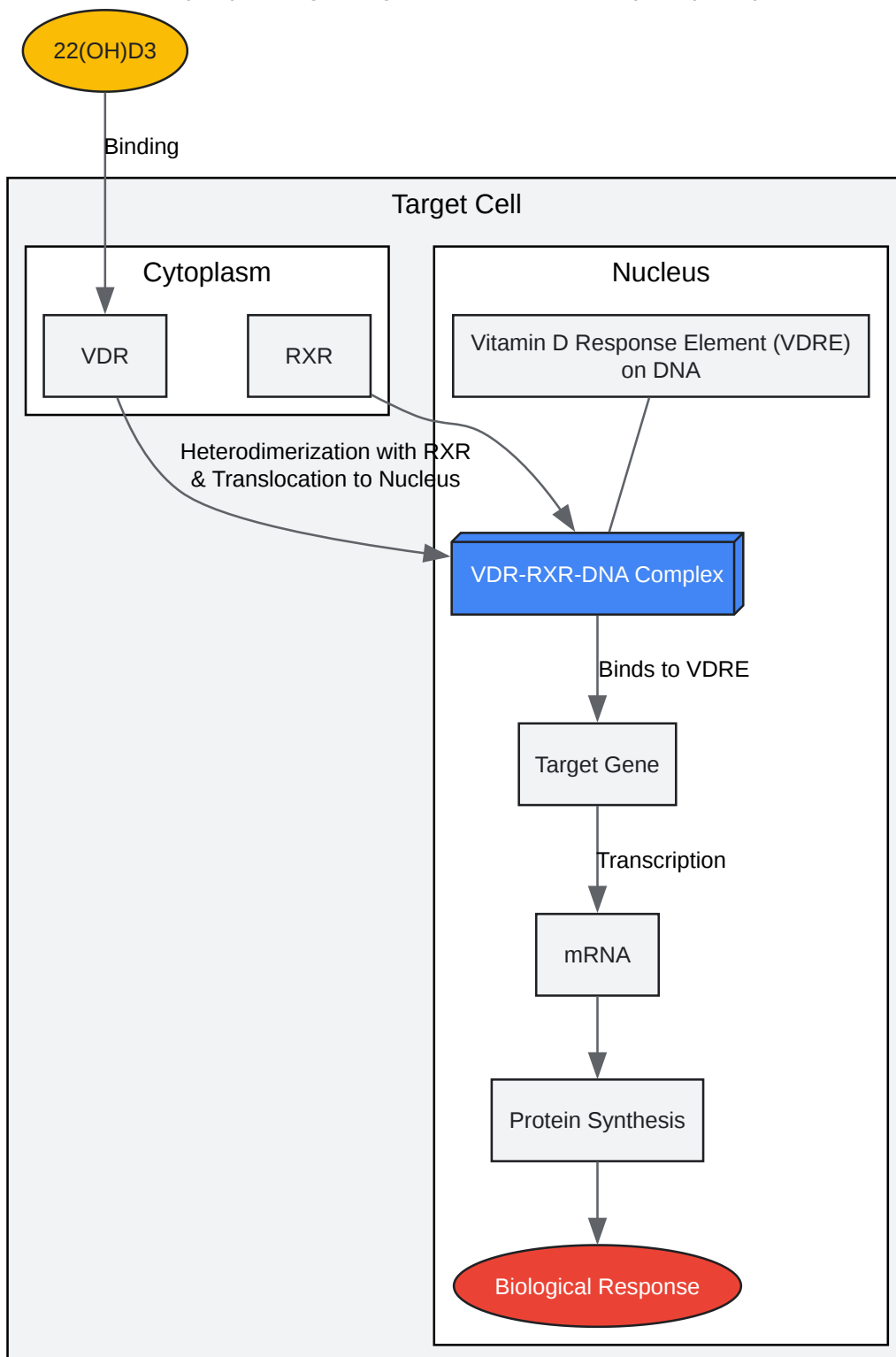

[Click to download full resolution via product page](#)

Need Custom Synthesis?

BenchChem offers custom synthesis for rare earth carbides and specific isotopic labeling.

Email: info@benchchem.com or [Request Quote Online](#).

References

- 1. Production of 22-hydroxy metabolites of vitamin d3 by cytochrome p450scc (CYP11A1) and analysis of their biological activities on skin cells - PubMed [pubmed.ncbi.nlm.nih.gov]
- 2. High throughput LC-MS/MS method for the simultaneous analysis of multiple vitamin D analytes in serum - PMC [[pmc.ncbi.nlm.nih.gov](https://pubmed.ncbi.nlm.nih.gov)]
- 3. Measurement of vitamin D metabolites by mass spectrometry, an analytical challenge - Zelzer - Journal of Laboratory and Precision Medicine [jlp.amegroups.org]
- 4. Simulation of Physicochemical and Pharmacokinetic Properties of Vitamin D3 and Its Natural Derivatives - PMC [[pmc.ncbi.nlm.nih.gov](https://pubmed.ncbi.nlm.nih.gov)]
- 5. Synthesis of Deuterium-Labeled Vitamin D Metabolites as Internal Standards for LC-MS Analysis - PMC [[pmc.ncbi.nlm.nih.gov](https://pubmed.ncbi.nlm.nih.gov)]
- 6. Synthesis of Deuterium-Labeled Vitamin D Metabolites as Internal Standards for LC-MS Analysis - PubMed [pubmed.ncbi.nlm.nih.gov]
- To cite this document: BenchChem. [Application Notes and Protocols for the Quantification of 22-Hydroxyvitamin D3]. BenchChem, [2026]. [Online PDF]. Available at: [<https://www.benchchem.com/product/b217047/docs#application-notes-and-protocols-for-the-quantification-of-22-hydroxyvitamin-d3>]

Disclaimer & Data Validity:

The information provided in this document is for Research Use Only (RUO) and is strictly not intended for diagnostic or therapeutic procedures. While BenchChem strives to provide accurate protocols, we make no warranties, express or implied, regarding the fitness of this product for every specific experimental setup.

Technical Support: The protocols provided are for reference purposes. Unsure if this reagent suits your experiment?

Need Industrial/Bulk Grade? [Request Custom Synthesis Quote](#)

BenchChem

Our mission is to be the trusted global source of essential and advanced chemicals, empowering scientists and researchers to drive progress in science and industry.

Contact

Address: 3281 E Guasti Rd
Ontario, CA 91761, United States
Phone: (601) 213-4426
Email: info@benchchem.com

[Contact our Ph.D. Support Team for a compatibility check](#)