

Technical Support Center: Minimizing Polydispersity in Polymers with **tert-Dodecylmercaptan**

Author: BenchChem Technical Support Team. **Date:** December 2025

Compound of Interest

Compound Name: *tert-Dodecylmercaptan*

Cat. No.: *B213132*

[Get Quote](#)

Welcome to the technical support center for controlling polymer polydispersity using **tert-dodecylmercaptan** (TDM). This resource is designed for researchers, scientists, and drug development professionals to provide clear, actionable guidance for your polymerization experiments.

Troubleshooting Guide

This guide addresses common issues encountered when using **tert-dodecylmercaptan** as a chain transfer agent (CTA).

Problem	Possible Causes	Suggested Solutions
High Polydispersity Index (PDI)	<ul style="list-style-type: none"> - Insufficient TDM Concentration: The amount of TDM may not be adequate to effectively control the chain growth. - Inappropriate Initiator Concentration: A high rate of initiation compared to chain transfer can lead to uncontrolled polymerization. - High Polymerization Temperature: Elevated temperatures can increase the rate of termination reactions, broadening the PDI. 	<ul style="list-style-type: none"> - Increase TDM Concentration: Systematically increase the concentration of TDM in your reaction. Refer to the data in Table 1 for guidance on the expected effect on molecular weight. - Optimize Initiator Concentration: Decrease the initiator-to-TDM ratio. A common starting point is a [CTA]/[Initiator] ratio of 5:1 to 10:1.^[1] - Lower Reaction Temperature: Consider reducing the polymerization temperature to favor chain transfer over termination.
Bimodal Molecular Weight Distribution	<ul style="list-style-type: none"> - Inefficient Mixing: Poor agitation can lead to localized areas of high monomer and low CTA concentration, resulting in a population of high molecular weight polymers. - Choice of Chain Transfer Agent: While TDM typically yields a monomodal distribution, other mercaptans like n-dodecyl mercaptan (DDM) have been observed to produce bimodal distributions in certain systems.^[2] 	<ul style="list-style-type: none"> - Improve Agitation: Ensure your reaction setup provides vigorous and consistent mixing to maintain a homogeneous distribution of all components. - Confirm CTA Identity: Verify that you are using tert-dodecylmercaptan and not another isomer.
Agglomeration or Coagulum Formation	<ul style="list-style-type: none"> - Inadequate Stabilization: Insufficient surfactant concentration can lead to poor stabilization of polymer particles.^[3] - High Monomer 	<ul style="list-style-type: none"> - Increase Surfactant Concentration: Incrementally increase the surfactant concentration to ensure adequate particle stabilization.

Concentration: Excessive monomer can cause swelling of polymer particles, reducing the effectiveness of the surfactant.[3]

[3] - Monomer-Starved Conditions: Employ a semi-batch process with slow, continuous addition of the monomer to maintain a low monomer concentration throughout the reaction.

Reduced Polymerization Rate

- High TDM Concentration: At very high concentrations, the chain transfer process can become so frequent that it slows the overall rate of polymer chain growth.

- Optimize TDM Concentration: While a higher TDM concentration reduces polydispersity, there is a trade-off with the reaction rate. Determine the optimal concentration that provides the desired PDI without significantly inhibiting the polymerization rate.

Frequently Asked Questions (FAQs)

Q1: How does **tert-dodecylmercaptan** (TDM) reduce the polydispersity of a polymer?

A1: **Tert-dodecylmercaptan** acts as a chain transfer agent. During polymerization, a growing polymer radical can abstract the hydrogen atom from the thiol group (-SH) of TDM. This terminates the growth of that polymer chain and creates a new thiyl radical (RS•). This new radical can then initiate the growth of a new polymer chain. This process of terminating existing chains and initiating new ones leads to a more uniform distribution of polymer chain lengths, thus reducing the polydispersity index (PDI).

Q2: What is the typical concentration range for **tert-dodecylmercaptan** in a polymerization reaction?

A2: The optimal concentration of TDM will vary depending on the specific monomer, initiator, and desired molecular weight of the polymer. However, a common range to start with is 0.1 to 2.0 parts per hundred monomer (phm). As the concentration of TDM increases, the molecular weight of the resulting polymer decreases.

Q3: Can I add all the **tert-dodecylmercaptan** at the beginning of the polymerization?

A3: Yes, in many batch polymerization processes, the TDM is added at the beginning of the reaction along with the monomer and initiator. For semi-batch processes, it can be added initially or co-fed with the monomer.

Q4: Will **tert-dodecylmercaptan** affect the chemical properties of my polymer?

A4: The primary role of TDM is to control the molecular weight and polydispersity. The TDM molecule is incorporated as an end-group on the polymer chains. For most applications, this has a negligible effect on the bulk chemical properties of the polymer.

Q5: Are there any safety precautions I should take when working with **tert-dodecylmercaptan**?

A5: Yes, **tert-dodecylmercaptan** has a strong, unpleasant odor and should be handled in a well-ventilated fume hood. Always consult the Safety Data Sheet (SDS) for detailed information on handling, storage, and personal protective equipment.

Data Presentation

The following table summarizes the effect of **tert-dodecylmercaptan** (TDM) concentration on the gel content of a pressure-sensitive adhesive. A lower gel content corresponds to a lower average molecular weight.

Table 1: Effect of TDM Concentration on Polymer Gel Content^[4]

TDM Concentration (phm)	Gel Content (%)
0.0	55
0.15	0

Note: This data is for a specific acrylic pressure-sensitive adhesive and should be used as a general guide. The effect of TDM on your specific polymer system may vary.

Experimental Protocols

Emulsion Polymerization of Styrene with **tert-Dodecylmercaptan**

This protocol describes a general procedure for the emulsion polymerization of styrene to produce polystyrene with a controlled molecular weight and low polydispersity.

Materials:

- Styrene (inhibitor removed)
- **tert-Dodecylmercaptan** (TDM)
- Potassium persulfate (KPS) (initiator)
- Sodium dodecyl sulfate (SDS) (surfactant)
- Sodium bicarbonate (buffer)
- Deionized water

Procedure:

- **Reactor Setup:** Assemble a jacketed glass reactor equipped with a mechanical stirrer, condenser, nitrogen inlet, and a port for additions.
- **Aqueous Phase Preparation:** In the reactor, combine deionized water, sodium dodecyl sulfate, and sodium bicarbonate.
- **Deoxygenation:** Purge the reactor with nitrogen for at least 30 minutes to remove dissolved oxygen.
- **Monomer and CTA Preparation:** In a separate vessel, mix the styrene monomer and the desired amount of **tert-dodecylmercaptan**.
- **Initiation:** Heat the reactor to the desired polymerization temperature (e.g., 70-80 °C).
- **Monomer Addition:** Add the styrene/TDM mixture to the reactor.

- **Initiator Addition:** Dissolve the potassium persulfate in a small amount of deionized water and add it to the reactor to initiate polymerization.
- **Polymerization:** Maintain the reaction at the set temperature with constant stirring for the desired reaction time (typically 2-6 hours).
- **Cooling:** Once the polymerization is complete, cool the reactor to room temperature.
- **Characterization:** Analyze the resulting polystyrene latex for molecular weight and polydispersity index (PDI) using Gel Permeation Chromatography (GPC).

Suspension Polymerization of Methyl Methacrylate (MMA) / Styrene Copolymer with **tert-Dodecylmercaptan**[5]

This protocol is adapted from a patented procedure for preparing a copolymer with controlled molecular weight.

Materials:

- Methyl methacrylate (MMA)
- Styrene
- Lauroyl peroxide (initiator)
- **tert-Dodecylmercaptan** (TDM)
- Poly(vinyl alcohol) (suspending agent)
- Disodium hydrogen phosphate (buffer)
- Deionized water

Procedure:

- **Aqueous Phase Preparation:** In a reactor, dissolve the poly(vinyl alcohol) and disodium hydrogen phosphate in deionized water.

- Organic Phase Preparation: In a separate vessel, dissolve the lauroyl peroxide and **tert-dodecylmercaptan** in the mixture of methyl methacrylate and styrene monomers.
- Dispersion: Add the organic phase to the aqueous phase in the reactor under stirring (e.g., 400 rpm) to form a suspension.
- First Polymerization: Heat the reactor to 80 °C to initiate polymerization.
- Second Polymerization: After the initial polymerization peak (approximately 1 hour and 40 minutes), raise the temperature to 115 °C and continue the reaction for another 25 minutes.
- Cooling and Isolation: Cool the reactor to 30 °C. The resulting polymer beads can be collected by filtration, washed with distilled water, and dried.
- Characterization: Analyze the molecular weight and PDI of the copolymer using GPC. The reported average molecular weight for this procedure is 133,000 with a PDI of 1.8.[5]

Visualizations

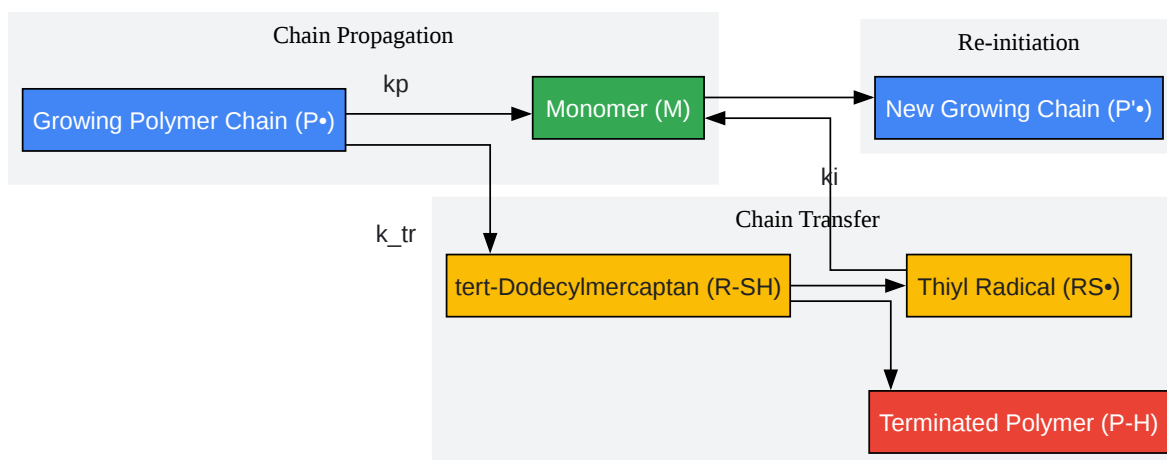

[Click to download full resolution via product page](#)

Caption: Mechanism of chain transfer with **tert-dodecylmercaptan**.

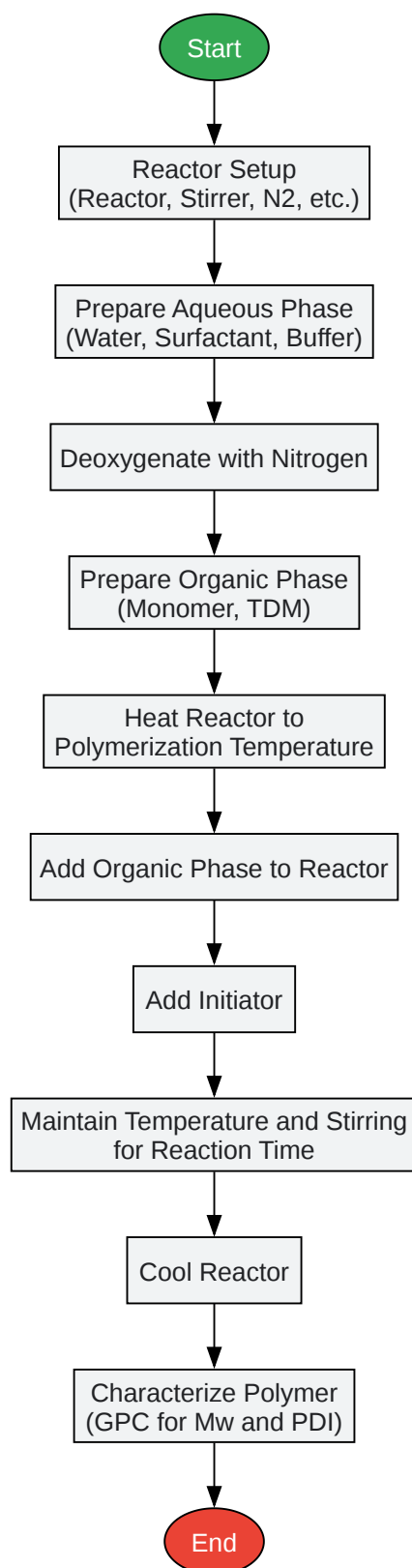

[Click to download full resolution via product page](#)

Caption: General experimental workflow for emulsion polymerization.

Need Custom Synthesis?

BenchChem offers custom synthesis for rare earth carbides and specific isotopic labeling.

Email: info@benchchem.com or [Request Quote Online](#).

References

- 1. benchchem.com [benchchem.com]
- 2. matchemmech.com [matchemmech.com]
- 3. benchchem.com [benchchem.com]
- 4. mdpi.com [mdpi.com]
- 5. KR100550444B1 - Method for preparing suspension polymerization of methyl methacrylate / styrene copolymer - Google Patents [patents.google.com]
- To cite this document: BenchChem. [Technical Support Center: Minimizing Polydispersity in Polymers with tert-Dodecylmercaptan]. BenchChem, [2025]. [Online PDF]. Available at: [https://www.benchchem.com/product/b213132#how-to-minimize-polydispersity-in-polymers-using-tert-dodecylmercaptan]

Disclaimer & Data Validity:

The information provided in this document is for Research Use Only (RUO) and is strictly not intended for diagnostic or therapeutic procedures. While BenchChem strives to provide accurate protocols, we make no warranties, express or implied, regarding the fitness of this product for every specific experimental setup.

Technical Support: The protocols provided are for reference purposes. Unsure if this reagent suits your experiment? [[Contact our Ph.D. Support Team for a compatibility check](#)]

Need Industrial/Bulk Grade? [Request Custom Synthesis Quote](#)

BenchChem

Our mission is to be the trusted global source of essential and advanced chemicals, empowering scientists and researchers to drive progress in science and industry.

Contact

Address: 3281 E Guasti Rd

Ontario, CA 91761, United States

Phone: (601) 213-4426

Email: info@benchchem.com