

computational modeling of benzimidazole-based compounds

Author: BenchChem Technical Support Team. **Date:** May 2026

Compound of Interest

Compound Name: *1,3-Dihydro-5,6-dinitro-2H-benzimidazol-2-one*

CAS No.: 3705-86-0

Cat. No.: B021077

[Get Quote](#)

Application Note: High-Performance Computational Profiling of Benzimidazole Scaffolds

Executive Summary

The benzimidazole scaffold is a "privileged structure" in medicinal chemistry, serving as the core pharmacophore for anthelmintic (albendazole), antiviral (maribavir), and anticancer agents. However, the scaffold's high nitrogen content and planarity can lead to solubility issues and off-target toxicity. This guide details a self-validating computational workflow to screen, optimize, and validate benzimidazole derivatives before synthesis. We utilize a multi-scalar approach: electronic profiling (DFT), static interaction modeling (Docking), and dynamic stability analysis (MD Simulations).

Module A: Electronic Structure Profiling (DFT)

Objective: To predict chemical reactivity and stability by calculating Frontier Molecular Orbitals (FMOs).

Rationale: Benzimidazoles act as electron donors/acceptors depending on the C2/N1 substitution. The HOMO-LUMO gap (

) is the primary descriptor for kinetic stability and intracellular reactivity.

Protocol 1: DFT Calculation Setup

- Software: Gaussian 16 / ORCA 5.0
- Functional/Basis Set: B3LYP/6-311++G(d,p).[\[1\]](#)[\[2\]](#)[\[3\]](#)
 - Why? The B3LYP hybrid functional balances computational cost with accuracy for organic electronic states. The diffuse functions (++) are critical for capturing the lone pair electrons on the benzimidazole nitrogens.
- Solvent Model: IEFPCM (Water) to mimic physiological conditions.

Step-by-Step Workflow:

- Geometry Optimization: Minimize the structure to a local energy minimum (Force threshold: Hartree/Bohr).
- Frequency Calculation: Ensure no imaginary frequencies exist (confirms a true minimum).
- Descriptor Extraction:
 - Chemical Hardness ():
 . High hardness implies high stability/low reactivity.
 - Electrophilicity Index (): Measures the propensity to accept electrons (crucial for Michael acceptor derivatives).

Visualization: DFT Workflow

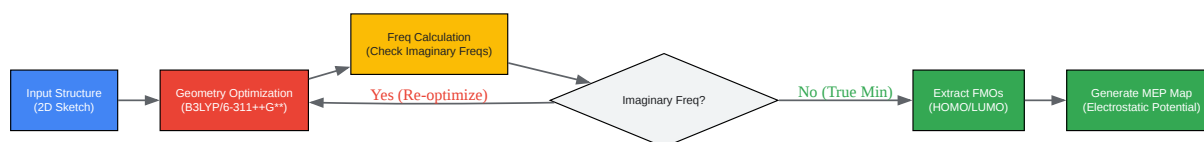

[Click to download full resolution via product page](#)

Figure 1: DFT workflow ensuring structural integrity before electronic property calculation.

Module B: Structure-Based Interaction Modeling (Docking)

Objective: To determine the binding mode of benzimidazole derivatives against Tubulin (specifically the colchicine binding site), a validated target for this scaffold.

Target Selection:

- Protein: Tubulin dimer.
- PDB ID:1SA0 (Complex with Colchicine).[4][5]
- Rationale: Benzimidazoles inhibit microtubule polymerization by occupying the colchicine pocket, preventing the "curved-to-straight" conformational change necessary for microtubule assembly.

Protocol 2: Molecular Docking (AutoDock Vina/Glide)

- Protein Preparation:
 - Remove crystallographic waters (except those bridging the ligand).
 - Add polar hydrogens (pH 7.4).

- Critical Step: Assign Gasteiger charges. Benzimidazole N3 is a hydrogen bond acceptor; NH1 is a donor.
- Grid Generation (The "Search Space"):
 - Center: X=119.6, Y=90.0, Z=5.7 (Coordinates of Colchicine in 1SA0).[4][5]
 - Size:
 - Å. Note: Do not make the box too large, or sampling efficiency drops.
- Validation (Self-Docking):
 - Remove the native Colchicine ligand and re-dock it.
 - Success Criteria: RMSD between the docked pose and crystal pose must be Å.

Data Output: Interaction Table

Typical interactions to look for in high-affinity benzimidazoles:

Residue (Tubulin)	Interaction Type	Benzimidazole Moiety
Cys241	H-Bond (Donor)	N3 (Imidazole ring)
Val238	Hydrophobic	Benzene ring
Alpha-Thr179	H-Bond	C2-Substituent

Visualization: Docking Logic

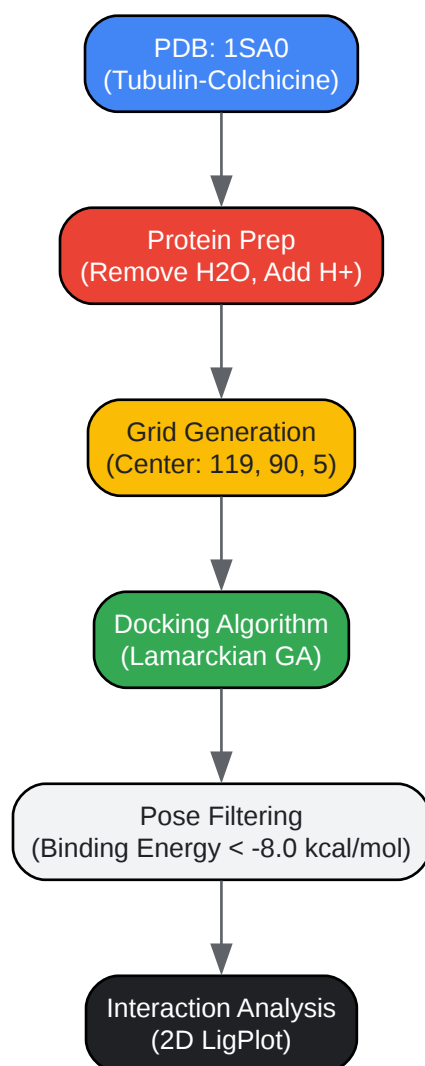

[Click to download full resolution via product page](#)

Figure 2: Structure-based docking pipeline targeting the colchicine binding site.

Module C: Dynamic Stability (MD Simulations)

Objective: To validate that the docked pose is stable over time and not a local energy artifact.

Docking is static; biology is dynamic.

Protocol 3: MD Simulation (GROMACS/Desmond)

- System Setup:
 - Force Field: CHARMM36 or OPLS_2005 (optimized for small heterocycles).

- Solvation: TIP3P water model (cubic box, 10 Å buffer).
- Neutralization: Add Na⁺/Cl⁻ ions to 0.15 M (physiological ionic strength).
- Equilibration:
 - NVT: 100 ps at 300 K (thermostat).
 - NPT: 100 ps at 1 bar (barostat).
- Production Run:
 - Duration: Minimum 50 ns (100 ns recommended for benzimidazoles to observe ring-flip phenomena).
 - Time Step: 2 fs.

Key Analysis Metrics:

- RMSD (Root Mean Square Deviation): Should plateau (converge) within 10-20 ns. A continuous rise indicates the ligand is leaving the pocket.
- RMSF (Fluctuation): High peaks in the protein RMSF usually indicate loop regions; the binding pocket residues (e.g., Cys241) should show reduced flexibility upon ligand binding.

Visualization: MD Simulation Pipeline

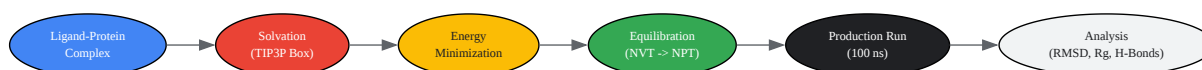

[Click to download full resolution via product page](#)

Figure 3: Molecular Dynamics simulation stages for stability verification.

Module D: ADMET & Drug-Likeness

Objective: To filter out toxic or bio-unavailable compounds early. Tool: SwissADME / pkCSM.[6]

Benzimidazole Specifics:

- Lipophilicity (LogP): Benzimidazoles can be highly lipophilic. Target a Consensus LogP < 5.
- BBB Permeation: If targeting CNS tumors (glioblastoma), the compound must cross the Blood-Brain Barrier (Yellow zone in SwissADME "Boiled-Egg" plot).
- CYP Inhibition: Check for CYP3A4 inhibition, common with imidazole-containing rings, which can cause drug-drug interactions.

References

- Bioinformation (2021): "Molecular docking and dynamic simulations of benzimidazoles with beta-tubulins." Detailed protocol for tubulin targeting.
- Journal of Medicinal Chemistry (2021): "Discovery of Novel Benzimidazole and Indazole Analogues as Tubulin Polymerization Inhibitors." Validation of the colchicine binding site.[5][7]
- Scientific Reports (2022): "Metal complexes of benzimidazole-derived as potential anti-cancer agents: combined experimental and computational studies." DFT and electronic parameter protocols.[1][2][8][9]
- SwissADME: "A free web tool to evaluate pharmacokinetics, drug-likeness and medicinal chemistry friendliness of small molecules."

Need Custom Synthesis?

BenchChem offers custom synthesis for rare earth carbides and specific isotopic labeling.

Email: info@benchchem.com or [Request Quote Online](#).

Sources

- [1. Repurposing benzimidazole and benzothiazole derivatives as potential inhibitors of SARS-CoV-2: DFT, QSAR, molecular docking, molecular dynamics simulation, and in-silico pharmacokinetic and toxicity studies - PMC \[pmc.ncbi.nlm.nih.gov\]](#)

- [2. irjweb.com \[irjweb.com\]](#)
- [3. Design, Synthesis, Docking, DFT, MD Simulation Studies of a New Nicotinamide-Based Derivative: In Vitro Anticancer and VEGFR-2 Inhibitory Effects \[mdpi.com\]](#)
- [4. pdfs.semanticscholar.org \[pdfs.semanticscholar.org\]](#)
- [5. Molecular docking and dynamic simulations of benzimidazoles with beta-tubulins - PMC \[pmc.ncbi.nlm.nih.gov\]](#)
- [6. isca.me \[isca.me\]](#)
- [7. researchgate.net \[researchgate.net\]](#)
- [8. researchgate.net \[researchgate.net\]](#)
- [9. Benzimidazole derivatives as a new scaffold of anticancer agents: Synthesis, optical properties, crystal structure and DFT calculations - PMC \[pmc.ncbi.nlm.nih.gov\]](#)
- To cite this document: BenchChem. [computational modeling of benzimidazole-based compounds]. BenchChem, [2026]. [Online PDF]. Available at: [\[https://www.benchchem.com/product/b021077/docs#computational-modeling-of-benzimidazole-based-compounds\]](https://www.benchchem.com/product/b021077/docs#computational-modeling-of-benzimidazole-based-compounds)

Disclaimer & Data Validity:

The information provided in this document is for Research Use Only (RUO) and is strictly not intended for diagnostic or therapeutic procedures. While BenchChem strives to provide accurate protocols, we make no warranties, express or implied, regarding the fitness of this product for every specific experimental setup.

Technical Support: The protocols provided are for reference purposes. Unsure if this reagent suits your experiment?

Need Industrial/Bulk Grade? [Request Custom Synthesis Quote](#)

BenchChem

Our mission is to be the trusted global source of essential and advanced chemicals, empowering scientists and researchers to drive progress in science and industry.

Contact

Address: 3281 E Guasti Rd

Ontario, CA 91761, United States

Phone: (601) 213-4426

Email: info@benchchem.com

[Contact our Ph.D. Support Team for a compatibility check](#)