

Low signal intensity issues for Didesmethyl sumatriptan detection

Author: BenchChem Technical Support Team. **Date:** May 2026

Compound of Interest

Compound Name: *Didesmethyl sumatriptan*

CAS No.: 88919-22-6

Cat. No.: B021133

[Get Quote](#)

Technical Support Center: Didesmethyl Sumatriptan Analysis

Welcome to the technical support guide for the bioanalysis of **Didesmethyl sumatriptan**. This document is designed for researchers, scientists, and drug development professionals who are encountering challenges, specifically low signal intensity, during the detection of this key sumatriptan metabolite. We will move beyond simple procedural lists to explore the underlying scientific principles, enabling you to diagnose issues and rationally design robust analytical methods.

Part 1: Understanding the Challenge: The Nature of Didesmethyl Sumatriptan

Low signal intensity is a frequent and frustrating issue in the quantification of **Didesmethyl sumatriptan**. The root of this problem lies in its fundamental physicochemical properties. As a secondary metabolite of sumatriptan, it undergoes significant structural changes that directly impact its analytical behavior.

Sumatriptan is metabolized by Cytochrome P450 enzymes, specifically CYP1A2 and CYP2D6, which sequentially remove the two methyl groups from the terminal amine.[1][2][3][4] This process transforms the tertiary amine of the parent drug into a primary amine in **Didesmethyl sumatriptan**.

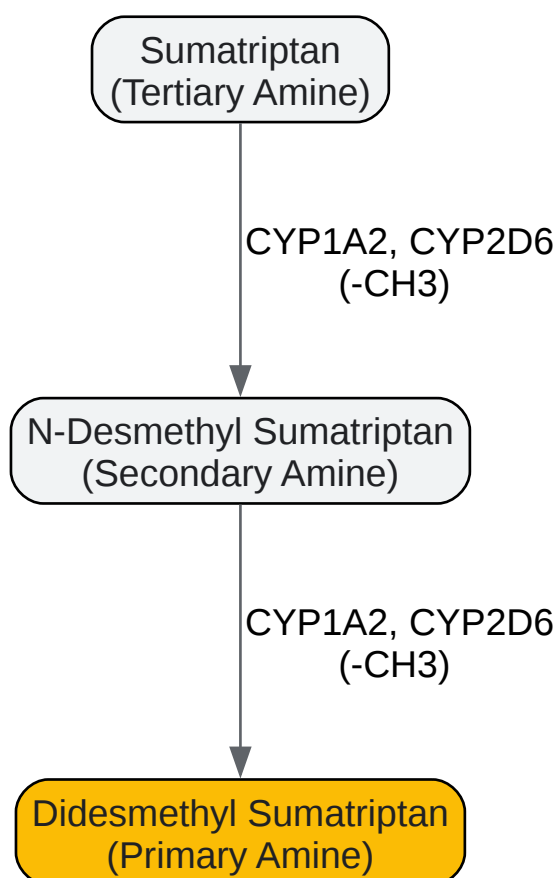

[Click to download full resolution via product page](#)

Caption: Metabolic pathway of Sumatriptan to **Didesmethyl sumatriptan**.

This demethylation has a critical consequence: a significant increase in polarity. The resulting primary amine group enhances the molecule's ability to form hydrogen bonds, making it more hydrophilic and less retained on traditional reversed-phase chromatography columns.

Compound	Molecular Formula	Molecular Weight (Da)	Calculated LogP	Key Structural Feature
Sumatriptan	C ₁₄ H ₂₁ N ₃ O ₂ S	295.40	0.93[5]	Tertiary Amine
Didesmethyl Sumatriptan	C ₁₂ H ₁₇ N ₃ O ₂ S	267.35	< 0.93 (More Polar)	Primary Amine

Table 1.
Physicochemical
property
comparison of
Sumatriptan and
its Didesmethyl
metabolite.

This inherent polarity is the central challenge that dictates our entire analytical strategy, from sample preparation to final detection.

Part 2: Frequently Asked Questions (FAQs)

Q1: Why is my **Didesmethyl sumatriptan** signal consistently low or non-existent?

A: This is typically due to a combination of four factors:

- **Poor Chromatographic Retention:** The high polarity of the analyte causes it to elute at or near the void volume in standard reversed-phase (RP-LC) methods, leading to poor peak shape and significant ion suppression.[6][7]
- **Inefficient Sample Preparation:** Standard liquid-liquid extraction (LLE) protocols designed for the less polar parent drug may have very low recovery for this hydrophilic metabolite.[8]
- **Matrix Effects:** Co-elution with endogenous biological components (salts, phospholipids) from the sample matrix can suppress the ionization of the analyte in the mass spectrometer source, drastically reducing signal.[9][10]
- **Suboptimal MS Parameters:** The ionization and fragmentation behavior of the primary amine in **Didesmethyl sumatriptan** differs from the tertiary amine in sumatriptan, requiring re-

optimization of all mass spectrometry settings.

Q2: What is the recommended LC method for such a polar compound?

A: While RP-LC can sometimes be adapted, Hydrophilic Interaction Liquid Chromatography (HILIC) is strongly recommended. HILIC utilizes a polar stationary phase and a high-organic mobile phase, which is ideal for retaining and separating highly polar compounds like **Didesmethyl sumatriptan**.^{[7][11][12]} This approach not only improves retention but also enhances MS sensitivity due to the high acetonitrile content of the mobile phase promoting more efficient desolvation and ionization.^[7]

Q3: Which ionization mode, positive or negative, should I use?

A: Positive Electrospray Ionization (ESI+) is the definitive choice. The primary amine group on **Didesmethyl sumatriptan** is basic and readily accepts a proton in the acidic mobile phases typically used for LC-MS, forming a stable $[M+H]^+$ ion.

Part 3: In-Depth Troubleshooting Guide

This guide provides a systematic approach to identifying and resolving low-signal issues, broken down by experimental stage.

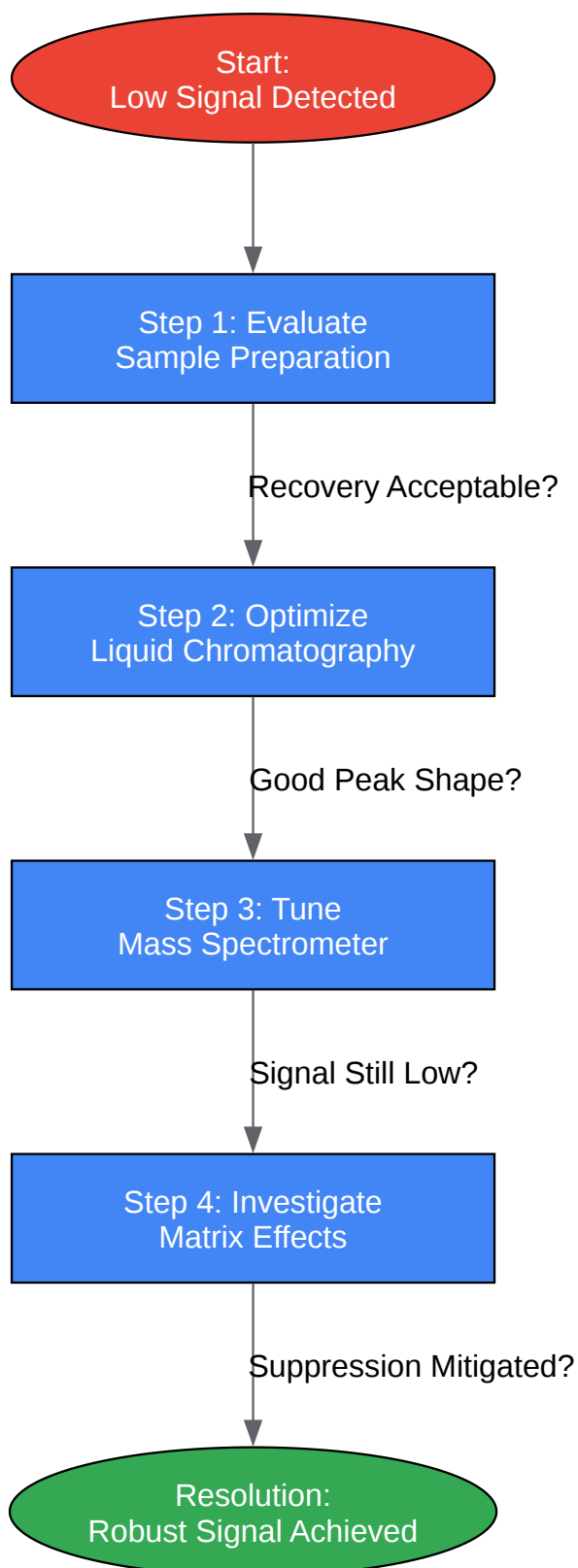

[Click to download full resolution via product page](#)

Caption: High-level troubleshooting workflow for low signal intensity.

Section 1: Sample Preparation Optimization

The goal of sample preparation is to efficiently extract the analyte from a complex biological matrix (e.g., plasma, urine) while removing interferences. For **Didesmethyl sumatriptan**, the choice of technique is critical to avoid significant analyte loss.

Problem: Very low or no analyte recovery post-extraction.

Causality: The chosen extraction method is not suitable for a highly polar metabolite. A method optimized for sumatriptan will likely fail for its more polar derivatives.

Technique	Principle	Pros for Didesmethyl Sumatriptan	Cons for Didesmethyl Sumatriptan
Protein Precipitation (PPT)	Protein denaturation with organic solvent (e.g., Acetonitrile, Methanol).	Simple, fast, non-selective (good for initial screening).	"Dirty" extract, high risk of severe matrix effects and ion suppression.[8][9]
Liquid-Liquid Extraction (LLE)	Partitioning between two immiscible liquid phases.	Can provide cleaner extracts than PPT if solvent is chosen carefully.	Traditional non-polar solvents (e.g., Hexane, MTBE) will result in very poor recovery. More polar solvents (e.g., Ethyl Acetate) are better but may still be inefficient. [13]
Solid-Phase Extraction (SPE)	Analyte is retained on a solid sorbent, interferences washed away.	Highest potential for good recovery and clean extracts. Allows for tailored chemistry (e.g., Mixed-Mode Cation Exchange).	Requires more extensive method development.

Recommended Solution & Protocol:

For robust quantification, a Mixed-Mode Cation Exchange SPE protocol is the most authoritative approach. This technique leverages both the polar nature and the positive charge of the primary amine for highly selective extraction.

Protocol: Mixed-Mode Cation Exchange SPE

- **Conditioning:** Pass 1 mL of Methanol through the SPE cartridge, followed by 1 mL of ultrapure water.
- **Equilibration:** Pass 1 mL of SPE Equilibration Buffer (e.g., 2% Formic Acid in water) through the cartridge.
- **Loading:** Dilute the plasma sample 1:1 with the Equilibration Buffer and load the diluted sample onto the cartridge.
- **Washing (Polar):** Wash the cartridge with 1 mL of an acidic aqueous solution (e.g., 2% Formic Acid in 5% Acetonitrile/Water) to remove salts and very polar interferences.
- **Washing (Non-Polar):** Wash the cartridge with 1 mL of a non-polar solvent (e.g., 100% Acetonitrile or Methanol) to remove lipids and other non-polar interferences.
- **Elution:** Elute the analyte using 1 mL of a basic organic solution (e.g., 5% Ammonium Hydroxide in Methanol). The base neutralizes the charge interaction, and the organic solvent disrupts the hydrophilic interaction, releasing the analyte.
- **Evaporation & Reconstitution:** Evaporate the eluate to dryness under a gentle stream of nitrogen and reconstitute in the initial mobile phase for HILIC analysis (e.g., 90:10 Acetonitrile:Water with buffer).

Section 2: Liquid Chromatography (LC) Strategy

As established, HILIC is the preferred separation mode. Poor chromatography is a primary source of signal loss due to co-elution with matrix components.

Problem: Poor peak shape (fronting, tailing, or split peaks) and unstable retention times.

Causality: Improper column choice, mobile phase composition, or injection solvent mismatch. In HILIC, the injection solvent must be weaker (higher in organic content) than the mobile

phase to ensure good peak shape.

Recommended Solution & Workflow:

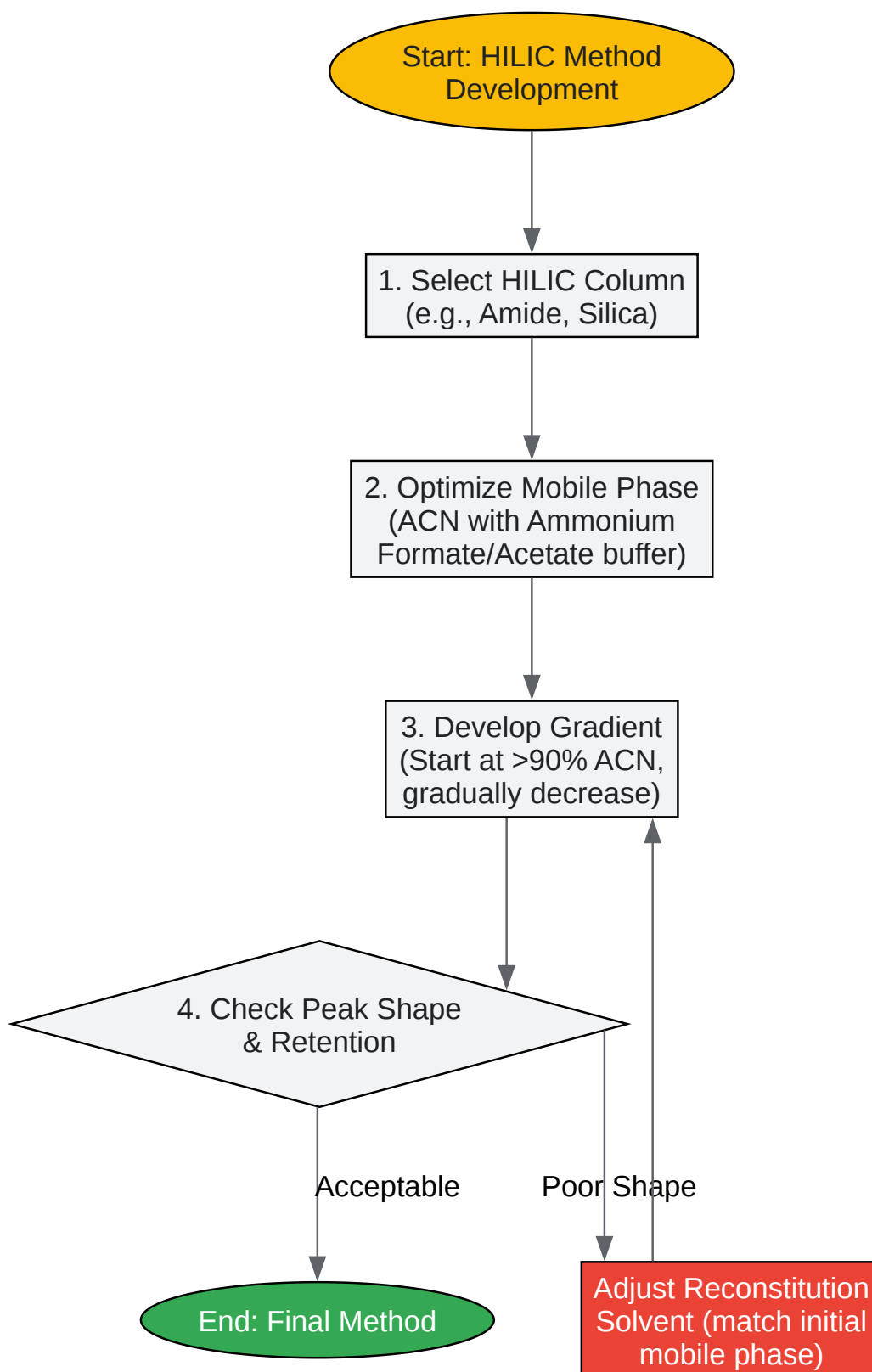

[Click to download full resolution via product page](#)

Caption: Workflow for developing a robust HILIC method.

HILIC Starting Parameters:

Parameter	Recommended Starting Condition	Rationale
Column	Amide- or Silica-based HILIC column (e.g., 100 x 2.1 mm, <3 µm)	Provides robust retention for polar, basic analytes.
Mobile Phase A	10 mM Ammonium Formate + 0.1% Formic Acid in Water	Buffered aqueous phase to control analyte charge state and improve peak shape.
Mobile Phase B	10 mM Ammonium Formate + 0.1% Formic Acid in 95:5 Acetonitrile:Water	High organic content for analyte retention.
Gradient	Start at 95% B, hold for 1 min, decrease to 50% B over 5 min, then recycle.	Ensures analyte is retained at injection and eluted as a sharp peak.
Flow Rate	0.3 - 0.5 mL/min	Typical for 2.1 mm ID columns.
Column Temp	40 °C	Improves efficiency and reduces mobile phase viscosity.
Injection Vol.	2 - 5 µL	
Reconstitution Solvent	90% Acetonitrile / 10% Water with buffer	Crucial: Must be similar to or weaker than the initial mobile phase to prevent peak distortion.

Section 3: Mass Spectrometry (MS) Tuning

Even with perfect sample prep and chromatography, a poorly tuned mass spectrometer will yield low signal.

Problem: Low precursor ion intensity or weak, inconsistent fragment ions.

Causality: Ion source parameters are not optimized for the analyte's desolvation, or the collision energy is incorrect for its fragmentation pattern.

Recommended Solution & Parameters:

Use a pure standard of **Didesmethyl sumatriptan** to perform tuning via direct infusion or flow injection analysis.

MS Starting Parameters (ESI+):

Parameter	Suggested Value	Rationale & Optimization Goal
Precursor Ion [M+H] ⁺	m/z 268.1	Calculated for C ₁₂ H ₁₇ N ₃ O ₂ S. Confirm with a full scan.
Product Ions (MRM)	Hypothesis 1: m/z 251.1 Hypothesis 2: m/z 44.1	1: Loss of NH ₃ (ammonia) from the side chain. 2: The ethylamine side chain fragment itself (CH ₂ -CH ₂ -NH ₂ ⁺). Optimize Collision Energy (CE) for each transition to find the most intense and stable fragment.
Capillary Voltage	3.5 - 4.5 kV	Optimize for stable spray and maximum precursor intensity.
Source Temperature	120 - 150 °C	Lower temperatures can sometimes be better for polar analytes to prevent thermal degradation.
Desolvation Temp.	400 - 550 °C	Increase to improve desolvation of the HILIC mobile phase.
Desolvation Gas Flow	800 - 1000 L/hr	Higher flow helps evaporate the high-organic mobile phase.
Collision Energy (CE)	15 - 35 eV	Must be empirically optimized for each product ion to achieve maximum intensity.

Section 4: Diagnosing and Mitigating Matrix Effects

If signal is still low after optimizing the above, matrix effects are the most likely culprit.^[14] This phenomenon occurs when co-eluting compounds from the biological sample interfere with the ionization process of the target analyte.^{[9][10]}

Diagnosis: Post-Column Infusion Experiment

This is the gold-standard method for visualizing regions of ion suppression in your chromatogram.

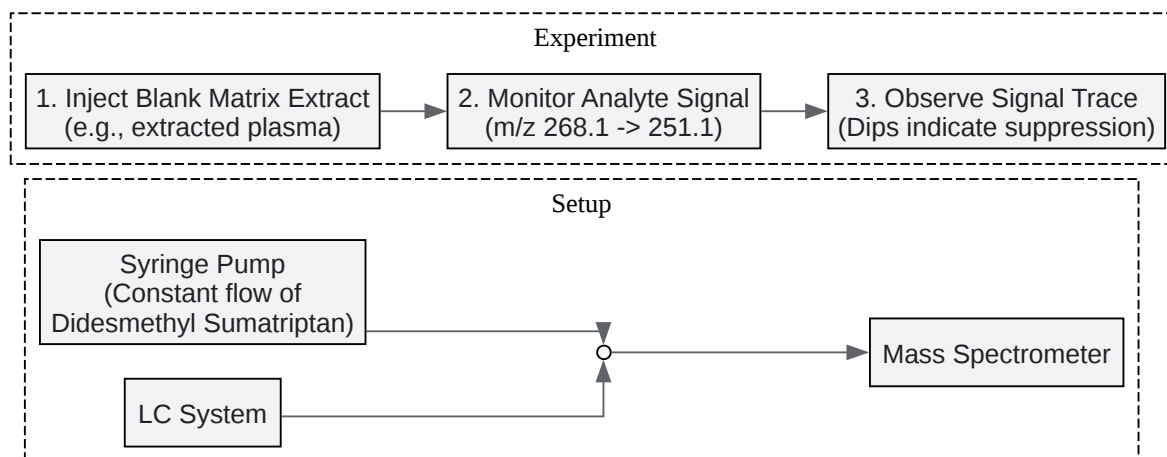

[Click to download full resolution via product page](#)

Caption: Experimental setup for a post-column infusion experiment.

Interpretation:

- You will see a stable, high baseline signal from the infused standard.
- When the blank matrix extract is injected, any "dips" or "valleys" in this baseline correspond to retention times where matrix components are eluting and causing ion suppression.
- If your analyte's retention time from the HILIC method falls within one of these valleys, your signal is being suppressed.

Mitigation Strategies:

- **Improve Chromatographic Separation:** Adjust the HILIC gradient to move the **Didesmethyl sumatriptan** peak away from the regions of ion suppression identified in the post-column infusion experiment.
- **Enhance Sample Cleanup:** If chromatographic adjustment is insufficient, the sample preparation method is not clean enough. Revert to Section 3.1 and implement a more rigorous SPE method to remove the interfering matrix components.
- **Use a Stable Isotope-Labeled Internal Standard (SIL-IS):** A SIL-IS (e.g., **Didesmethyl sumatriptan-d4**) is the ultimate tool to compensate for matrix effects. It is chemically identical and will co-elute, experiencing the exact same ion suppression or enhancement as the analyte. The ratio of analyte to IS will remain constant, ensuring accurate quantification even with signal variability.

By systematically addressing each of these areas—from understanding the analyte's properties to fine-tuning the instrumentation—you can overcome the challenges of low signal intensity and develop a sensitive, robust, and reliable method for the quantification of **Didesmethyl sumatriptan**.

References

- Dai, Y., & Hsiao, J. J. (n.d.). Discovery Metabolomics LC/MS Methods Optimized for Polar Metabolites. Agilent Technologies, Inc.
- Kaczmarek, M., et al. (2023). Optimization Strategies for Mass Spectrometry-Based Untargeted Metabolomics Analysis of Small Polar Molecules in Human Plasma. *Metabolites*, 13(8), 923. Available at: [\[Link\]](#)
- Pöstges, F., & Lehr, M. (2023). Metabolism of sumatriptan revisited. *Pharmacology Research & Perspectives*, 11(1), e01051. Available at: [\[Link\]](#)
- Rhoades, S., & Weljie, A. (2017). Comprehensive Optimization of LC-MS Metabolomics Methods Using Design of Experiments (COLMeD). *Metabolomics*, 13(1), 1. Available at: [\[Link\]](#)
- Kim, Y., et al. (2017). Determination of sumatriptan in human plasma using liquid chromatography-mass spectrometry for pharmacokinetic study in healthy Korean volunteers. *Translational and Clinical Pharmacology*, 25(2), 90-96. Available at: [\[Link\]](#)

- Pöstges, F., & Lehr, M. (2023). Metabolism of sumatriptan revisited. *Pharmacology Research & Perspectives*, 11(1), e01051. Available at: [\[Link\]](#)
- ResearchGate. (n.d.). Metabolism of sumatriptan published in literature. Available at: [\[Link\]](#)
- ResearchGate. (n.d.). (PDF) Metabolism of sumatriptan revisited. Available at: [\[Link\]](#)
- Löfgren, L. (2017). Development of UPLC-MS/MS method for the determination of polar metabolites. *Diva-portal.org*. Available at: [\[Link\]](#)
- Rhoades, S., & Weljie, A. (2016). Comprehensive Optimization of LC-MS Metabolomics Methods Using Design of Experiments (COLMeD). *Metabolomics*, 13(1), 1. Available at: [\[Link\]](#)
- Krol, G. J., et al. (1995). Screening and identification of sumatriptan and its main metabolite by means of thin-layer chromatography, ultraviolet spectroscopy and gas chromatography/mass spectrometry. *Arzneimittelforschung*, 45(9), 941-946. Available at: [\[Link\]](#)
- ResearchGate. (n.d.). Matrix effect of sumatriptan in nine lots of human plasma (n = 3). Available at: [\[Link\]](#)
- MDPI. (2024). Optimizing MS-Based Multi-Omics: Comparative Analysis of Protein, Metabolite, and Lipid Extraction Techniques. Available at: [\[Link\]](#)
- ResearchGate. (n.d.). HPLC method for the determination of sumatriptan in plasma and brain tissue. Available at: [\[Link\]](#)
- Kaczmarek, M., et al. (2023). Optimization Strategies for Mass Spectrometry-Based Untargeted Metabolomics Analysis of Small Polar Molecules in Human Plasma. *Metabolites*, 13(8), 923. Available at: [\[Link\]](#)
- Singh, S., et al. (2001). Determination of degradation products of sumatriptan succinate using LC-MS and LC-MS-MS. *Journal of Pharmaceutical and Biomedical Analysis*, 26(3), 367-377. Available at: [\[Link\]](#)

- ResearchGate. (2015). (PDF) Validated high performance liquid chromatography (HPLC) method for the determination of sumatriptan in rabbit plasma: Application to pharmacokinetic study. Available at: [\[Link\]](#)
- International Journal of Pharmaceutical and Phytopharmacological Research. (n.d.). Matrix effect in bioanalysis: An overview. Available at: [\[Link\]](#)
- ResearchGate. (n.d.). (PDF) Recent progress in polar metabolite quantification in plants using liquid chromatography – mass spectrometry (LC-MS). Available at: [\[Link\]](#)
- Kielbasa, A., et al. (2020). Development of an LC-MS Targeted Metabolomics Methodology to Study Proline Metabolism in Mammalian Cell Cultures. *Metabolites*, 10(10), 405. Available at: [\[Link\]](#)
- Rojo, D., et al. (2012). LC-MS metabolomics of polar compounds. *Bioanalysis*, 4(10), 1235-1243. Available at: [\[Link\]](#)
- ResearchGate. (2017). (PDF) Determination of sumatriptan in human plasma using liquid chromatography-mass spectrometry for pharmacokinetic study in healthy Korean volunteers. Available at: [\[Link\]](#)
- National Center for Biotechnology Information. (n.d.). Sumatriptan. PubChem Compound Database. Available at: [\[Link\]](#)
- Der Pharma Chemica. (2017). Identification of Unknown Impurity by Advanced Spectroscopy Techniques in the Sumatriptan Base Which Degraded into Sumatriptan I. Available at: [\[Link\]](#)
- National Center for Biotechnology Information. (n.d.). **Didesmethyl sumatriptan**. PubChem Compound Database. Available at: [\[Link\]](#)
- International Journal of MediPharm Research. (2015). Review Article on Matrix Effect in Bioanalytical Method Development. Available at: [\[Link\]](#)
- Wichitnithad, W., et al. (2020). Development and Validation of Liquid Chromatography-Tandem Mass Spectrometry Method for Simple Analysis of Sumatriptan and its Application in Bioequivalence Study. *Molecules*, 25(3), 488. Available at: [\[Link\]](#)

- EMA. (2016). Sumatriptan. Available at: [\[Link\]](#)
- ClinPGx. (n.d.). sumatriptan. Available at: [\[Link\]](#)
- Wichitnithad, W., et al. (2020). Development and Validation of Liquid Chromatography-Tandem Mass Spectrometry Method for Simple Analysis of Sumatriptan and its Application in Bioequivalence Study. *Molecules*, 25(3), 488. Available at: [\[Link\]](#)
- ClinPGx. (n.d.). Metabolism of sumatriptan revisited. Available at: [\[Link\]](#)
- Wang, S., et al. (2008). Matrix effect in bio-analysis of illicit drugs with LC-MS/MS: influence of ionization type, sample preparation, and biofluid. *Journal of the American Society for Mass Spectrometry*, 19(5), 643-652. Available at: [\[Link\]](#)
- Kiontke, A., et al. (2016). Electrospray Ionization Efficiency Is Dependent on Different Molecular Descriptors with Respect to Solvent pH and Instrumental Configuration. *PLOS ONE*, 11(9), e0162228. Available at: [\[Link\]](#)
- Stewart, J. T., et al. (2001). Determination of antimigraine compounds rizatriptan, zolmitriptan, naratriptan and sumatriptan in human serum by liquid chromatography/electrospray tandem mass spectrometry. *Rapid Communications in Mass Spectrometry*, 15(24), 2551-2557. Available at: [\[Link\]](#)
- Yan, Z., et al. (2016). Signal interference between drugs and metabolites in LC-ESI-MS quantitative analysis and its evaluation strategy. *Scientific Reports*, 6, 26088. Available at: [\[Link\]](#)
- MDPI. (2024). Moderate Signal Enhancement in Electrospray Ionization Mass Spectrometry by Focusing Electrospray Plume with a Dielectric Layer around the Mass Spectrometer's Orifice. Available at: [\[Link\]](#)

Need Custom Synthesis?

BenchChem offers custom synthesis for rare earth carbides and specific isotopic labeling.

Email: info@benchchem.com or [Request Quote Online](#).

Sources

- [1. Metabolism of sumatriptan revisited - PubMed \[pubmed.ncbi.nlm.nih.gov\]](#)
- [2. Metabolism of sumatriptan revisited - PMC \[pmc.ncbi.nlm.nih.gov\]](#)
- [3. researchgate.net \[researchgate.net\]](#)
- [4. ClinPGx \[clinpgx.org\]](#)
- [5. Sumatriptan | C14H21N3O2S | CID 5358 - PubChem \[pubchem.ncbi.nlm.nih.gov\]](#)
- [6. diva-portal.org \[diva-portal.org\]](#)
- [7. Development of an LC-MS Targeted Metabolomics Methodology to Study Proline Metabolism in Mammalian Cell Cultures - PMC \[pmc.ncbi.nlm.nih.gov\]](#)
- [8. researchgate.net \[researchgate.net\]](#)
- [9. eijppr.com \[eijppr.com\]](#)
- [10. medipharmsai.com \[medipharmsai.com\]](#)
- [11. hpst.cz \[hpst.cz\]](#)
- [12. \[PDF\] LC-MS metabolomics of polar compounds. | Semantic Scholar \[semanticscholar.org\]](#)
- [13. Determination of sumatriptan in human plasma using liquid chromatography-mass spectrometry for pharmacokinetic study in healthy Korean volunteers - PMC \[pmc.ncbi.nlm.nih.gov\]](#)
- [14. Matrix effect in bio-analysis of illicit drugs with LC-MS/MS: influence of ionization type, sample preparation, and biofluid - PubMed \[pubmed.ncbi.nlm.nih.gov\]](#)
- To cite this document: BenchChem. [Low signal intensity issues for Didesmethyl sumatriptan detection]. BenchChem, [2026]. [Online PDF]. Available at: [\[https://www.benchchem.com/product/b021133/docs#low-signal-intensity-issues-for-didesmethyl-sumatriptan-detection\]](https://www.benchchem.com/product/b021133/docs#low-signal-intensity-issues-for-didesmethyl-sumatriptan-detection)

Disclaimer & Data Validity:

The information provided in this document is for Research Use Only (RUO) and is strictly not intended for diagnostic or therapeutic procedures. While BenchChem strives to provide accurate protocols, we make no warranties, express or implied, regarding the fitness of this product for every specific experimental setup.

Technical Support: The protocols provided are for reference purposes. Unsure if this reagent suits your experiment?

Need Industrial/Bulk Grade? [Request Custom Synthesis Quote](#)

BenchChem

Our mission is to be the trusted global source of essential and advanced chemicals, empowering scientists and researchers to drive progress in science and industry.

Contact

Address: 3281 E Guasti Rd
Ontario, CA 91761, United States
Phone: (601) 213-4426
Email: info@benchchem.com

[Contact our Ph.D. Support Team for a compatibility check](#)