

A Comprehensive Guide to Personal Protective Equipment for Handling Nonadecanophenone

Author: BenchChem Technical Support Team. **Date:** May 2026

Compound of Interest

Compound Name: Nonadecanophenone

CAS No.: 103044-68-4

Cat. No.: B020716

[Get Quote](#)

Prepared by a Senior Application Scientist

This document provides essential safety protocols and logistical guidance for the handling and disposal of **Nonadecanophenone**. As a compound with limited publicly available, substance-specific safety data, we will proceed under the precautionary principle. This guide is structured to empower researchers, scientists, and drug development professionals with a robust framework for safe laboratory operations, grounded in established chemical safety standards.

Hazard Analysis: Operating with the Precautionary Principle

A thorough review of established safety databases reveals a lack of a comprehensive Safety Data Sheet (SDS) specifically for **Nonadecanophenone** (CAS No: 103044-68-4). In such situations, best laboratory practice dictates treating the substance as potentially hazardous until empirical data proves otherwise. The physical properties available indicate it is a white solid with a melting point of 65°C^[1].

While direct hazard information is unavailable, analysis of structurally related compounds can suggest potential, though unconfirmed, risks. For instance, some long-chain aliphatic hydrocarbons carry an aspiration toxicity warning[2], and certain long-chain carboxylic acids are known to be irritants[3]. Therefore, our operational plan is built on a conservative assessment that mitigates risks such as skin or eye irritation, inhalation of airborne particulates, and accidental ingestion.

Table 1: Known Physical Properties of **Nonadecanophenone**

Property	Value	Source
CAS Number	103044-68-4	Lab Pro Inc.[1]
Molecular Formula	C ₂₅ H ₄₂ O	Lab Pro Inc.[1]
Molecular Weight	358.61 g/mol	Lab Pro Inc.[1]
Physical State	Solid	Lab Pro Inc.[1]
Color	White	Lab Pro Inc.[1]

| Melting Point | 65°C | Lab Pro Inc.[1] |

Engineering Controls: The First Line of Defense

Personal protective equipment (PPE) is the final barrier between a researcher and a potential hazard. Before any handling, engineering controls must be prioritized to minimize exposure.

- **Ventilation:** All procedures involving **Nonadecanophenone**, especially the handling of its solid form, should be conducted within a certified chemical fume hood or a powder containment hood.[4] This prevents the inhalation of any fine particulates that may become airborne.
- **Designated Area:** Establish a designated area for handling **Nonadecanophenone** to prevent cross-contamination of other laboratory surfaces.

Personal Protective Equipment (PPE) Protocol

The selection of appropriate PPE is contingent on the specific procedure being performed. The following protocol provides a step-by-step guide to ensure comprehensive protection. All PPE should be used in accordance with the OSHA PPE standard (29 CFR 1910.132)[5].

Table 2: Recommended PPE for Handling **Nonadecanophenone**

Task	Eye/Face Protection	Hand Protection	Body Protection	Respiratory Protection
Storage & Transport (Closed Container)	Safety glasses	Not required	Lab coat	Not required
Weighing/Transferring Solid	Chemical safety goggles	Nitrile gloves	Lab coat	NIOSH-approved N95 respirator[6]
Preparing Solutions	Chemical safety goggles and face shield	Nitrile gloves	Lab coat	Recommended if not in a fume hood

| Spill Cleanup | Chemical safety goggles and face shield | Heavy-duty nitrile or butyl rubber gloves | Chemical-resistant apron or gown | NIOSH-approved respirator (N95 minimum)[6] |

Eye and Face Protection

Direct contact with chemical solids or solutions can cause serious eye irritation or damage.

- Minimum Requirement: At a minimum, ANSI Z87.1-compliant chemical safety goggles must be worn during any operation where **Nonadecanophenone** is handled.[6][7]
- Splash Hazard: When preparing solutions or performing any task with a risk of splashing, a full-face shield must be worn in addition to safety goggles.[6][8]

Skin and Body Protection

To prevent skin contact, which could lead to unknown irritation or absorption, appropriate protective garments are essential.

- **Gloves:** Nitrile examination gloves are the recommended minimum for handling **Nonadecanophenone**.^[8] Always inspect gloves for tears or punctures before use and practice proper removal techniques to avoid contaminating your skin.^[4] For spill cleanup or extended contact, more robust, chemical-resistant gloves may be necessary.
- **Lab Coat:** A clean, buttoned lab coat must be worn at all times to protect street clothes and skin from contamination.

Respiratory Protection

As a solid, the primary inhalation risk from **Nonadecanophenone** comes from fine powders or aerosols.

- **Handling Powders:** When weighing or transferring the solid material, a NIOSH-approved N95 filtering facepiece respirator is mandatory to prevent the inhalation of airborne particulates.^[6] All respirator use must be part of a comprehensive respiratory protection program that adheres to OSHA standard 29 CFR 1910.134, including medical clearance, training, and fit-testing.^[5]
- **General Use:** For other procedures within a fume hood, additional respiratory protection may not be necessary if the engineering controls are functioning correctly.

Diagram 1: PPE Selection Workflow This diagram outlines the decision-making process for selecting the appropriate level of PPE when handling **Nonadecanophenone**.

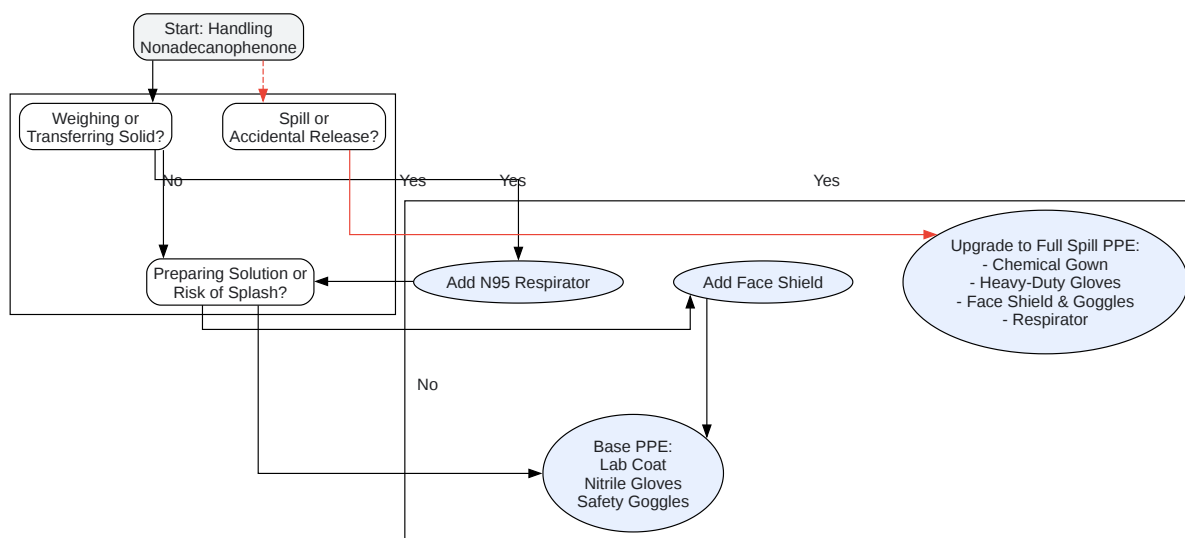

[Click to download full resolution via product page](#)

Need Custom Synthesis?

BenchChem offers custom synthesis for rare earth carbides and specific isotopic labeling.

Email: info@benchchem.com or [Request Quote Online](#).

Sources

- [1. labproinc.com \[labproinc.com\]](http://labproinc.com)
- [2. fishersci.com \[fishersci.com\]](http://fishersci.com)
- [3. cdn.caymanchem.com \[cdn.caymanchem.com\]](http://cdn.caymanchem.com)
- [4. cdhfinechemical.com \[cdhfinechemical.com\]](http://cdhfinechemical.com)
- [5. Potential Exposures and PPE Recommendations | Substance Use | CDC \[cdc.gov\]](#)
- [6. s16377.pcdn.co \[s16377.pcdn.co\]](http://s16377.pcdn.co)
- [7. fishersci.com \[fishersci.com\]](http://fishersci.com)
- [8. uml.edu \[uml.edu\]](http://uml.edu)
- To cite this document: BenchChem. [A Comprehensive Guide to Personal Protective Equipment for Handling Nonadecanophenone]. BenchChem, [2026]. [Online PDF]. Available at: [<https://www.benchchem.com/product/b020716/docs#a-comprehensive-guide-to-personal-protective-equipment-for-handling-nonadecanophenone>]

Disclaimer & Data Validity:

The information provided in this document is for Research Use Only (RUO) and is strictly not intended for diagnostic or therapeutic procedures. While BenchChem strives to provide accurate protocols, we make no warranties, express or implied, regarding the fitness of this product for every specific experimental setup.

Technical Support: The protocols provided are for reference purposes. Unsure if this reagent suits your experiment?

Need Industrial/Bulk Grade? [Request Custom Synthesis Quote](#)

BenchChem

Our mission is to be the trusted global source of essential and advanced chemicals, empowering scientists and researchers to drive progress in science and industry.

Contact

Address: 3281 E Guasti Rd

Ontario, CA 91761, United States

Phone: (601) 213-4426

Email: info@benchchem.com

Contact our Ph.D. Support Team for a compatibility check