

A Comparative Analysis of Biphenylamines in the Synthesis of Novel Fungicides

Author: BenchChem Technical Support Team. **Date:** December 2025

Compound of Interest

Compound Name: *4'-Chloro-[1,1'-biphenyl]-2-amine*

Cat. No.: *B196108*

[Get Quote](#)

For Researchers, Scientists, and Drug Development Professionals

The quest for novel, potent, and environmentally benign fungicides is a continuous endeavor in agrochemical research. Biphenylamine derivatives have emerged as a promising scaffold in the design of new fungicidal agents due to their structural versatility and diverse biological activities. This guide provides a comparative study of different biphenylamines in fungicide synthesis, offering insights into their structure-activity relationships, synthetic methodologies, and mechanisms of action. The information presented herein is supported by experimental data from various studies to aid researchers in the development of next-generation fungicides.

Comparative Efficacy of Biphenylamine-Based Fungicides

The fungicidal efficacy of biphenylamine derivatives is significantly influenced by the nature and position of substituents on the biphenyl rings. The following tables summarize the in vitro and in vivo activities of representative compounds against various phytopathogenic fungi.

In Vitro Fungicidal Activity of Biphenylamine Carboxamide Derivatives against Various Fungi

Compound ID	Target Fungi	EC50 (mg/L)	Reference
Boscalid	Botrytis cinerea	2.1	[Commercial Standard]
Sclerotinia sclerotiorum	0.8	[Commercial Standard]	
Rhizoctonia solani	0.5	[Commercial Standard]	
Bixafen	Botrytis cinerea	1.5	[Commercial Standard]
Sclerotinia sclerotiorum	0.6	[Commercial Standard]	
Rhizoctonia solani	0.3	[Commercial Standard]	
Compound 4f	Pseudoperonospora cubensis	1.96	[1]
Compound 4a	Pseudoperonospora cubensis	4.69	[1]
Diflumetorim	Pseudoperonospora cubensis	21.44	[1]
Flumorph	Pseudoperonospora cubensis	7.55	[1]

In Vivo Fungicidal Activity of Diphenylamine Derivatives

Compound ID	Target Disease	Concentration (mg/L)	Control Efficacy (%)	Reference
P30	Cucumber downy mildew	12.5	80	[2]
Rice blast	0.3	100	[2]	
Cucumber gray mold	0.9	100	[2]	
P33	Cucumber downy mildew	12.5	85	[2]
Rice blast	0.3	100	[2]	
Cucumber gray mold	0.9	100	[2]	
SYAUP-CN-26	Tomato gray mold (protective)	200	83.11	[3]
Tomato gray mold (curative)	200	47.52	[3]	

Experimental Protocols

Detailed and reproducible experimental protocols are crucial for the synthesis and evaluation of novel fungicidal compounds. Below are representative synthetic procedures for biphenylamine-based fungicides.

General Synthesis of Biphenylamine Intermediates via Suzuki-Miyaura Coupling

A common and efficient method for constructing the biphenylamine scaffold is the Suzuki-Miyaura cross-coupling reaction.[4] This reaction typically involves the coupling of an aryl halide with an arylboronic acid in the presence of a palladium catalyst and a base.

Materials:

- Ortho-substituted aniline (e.g., 2-chloroaniline)
- Substituted phenylboronic acid
- Palladium(II) acetate (Pd(OAc)₂)
- Phosphine ligand (e.g., SPhos, XPhos)
- Base (e.g., K₂CO₃, Cs₂CO₃)
- Solvent (e.g., Toluene, Dioxane, DMF)

Procedure:

- To a reaction vessel purged with an inert gas (e.g., nitrogen or argon), add the ortho-substituted aniline (1.0 eq), substituted phenylboronic acid (1.2 eq), palladium(II) acetate (0.02 eq), phosphine ligand (0.04 eq), and base (2.0 eq).
- Add the anhydrous solvent and stir the mixture at the desired temperature (typically 80-120 °C) for the specified reaction time (usually 4-24 hours), monitoring the reaction progress by TLC or GC-MS.
- Upon completion, cool the reaction mixture to room temperature and dilute with an organic solvent (e.g., ethyl acetate).
- Wash the organic layer with water and brine, then dry over anhydrous sodium sulfate.
- Concentrate the solvent under reduced pressure and purify the crude product by column chromatography on silica gel to obtain the desired biphenylamine intermediate.

Synthesis of N-(alkoxy)-Diphenyl Ether Carboxamide Derivatives[5]

Step 1: Synthesis of Diphenyl Ether Intermediate

- Dissolve hydroquinone (1.5 eq) and potassium carbonate (2.0 eq) in DMF.
- Heat the mixture to approximately 110°C for 30 minutes with stirring.

- Add 4-fluorobenzonitrile (1.0 eq) and continue the reaction for 4 hours, monitoring by TLC.
- After completion, add water and extract the product with ethyl acetate.
- Wash the combined organic layers with saturated brine, dry over anhydrous sodium sulfate, and concentrate to obtain the solid intermediate.

Step 2: Synthesis of the Final Carboxamide

- Dissolve the diphenyl ether intermediate (1.0 eq) and the appropriate N-alkoxy amine (2.0 eq) in DCM.
- Add HATU (1.1 eq) and triethylamine (2.0 eq) to the solution.
- Stir the mixture at room temperature for 3 hours, monitoring by TLC.
- Upon completion, add saturated NaHCO₃ solution and extract with DCM.
- Dry the organic layer with anhydrous sodium sulfate and concentrate under reduced pressure.
- Purify the crude product by silica gel column chromatography to yield the final N-(alkoxy)-diphenyl ether carboxamide.

Mechanisms of Action and Signaling Pathways

Many biphenylamine-based fungicides exert their effects by targeting specific enzymes essential for fungal survival. Two prominent targets are Succinate Dehydrogenase (SDH) and Lanosterol 14 α -demethylase (CYP51).

Succinate Dehydrogenase Inhibition

Succinate Dehydrogenase Inhibitors (SDHIs) are a major class of fungicides that includes several biphenylamine carboxamides like boscalid and bixafen.^[5] SDH is a key enzyme complex (Complex II) in the mitochondrial electron transport chain and the tricarboxylic acid (TCA) cycle. By binding to the ubiquinone-binding site of the SDH complex, these fungicides block the oxidation of succinate to fumarate, thereby inhibiting cellular respiration and leading to fungal cell death.^[6]

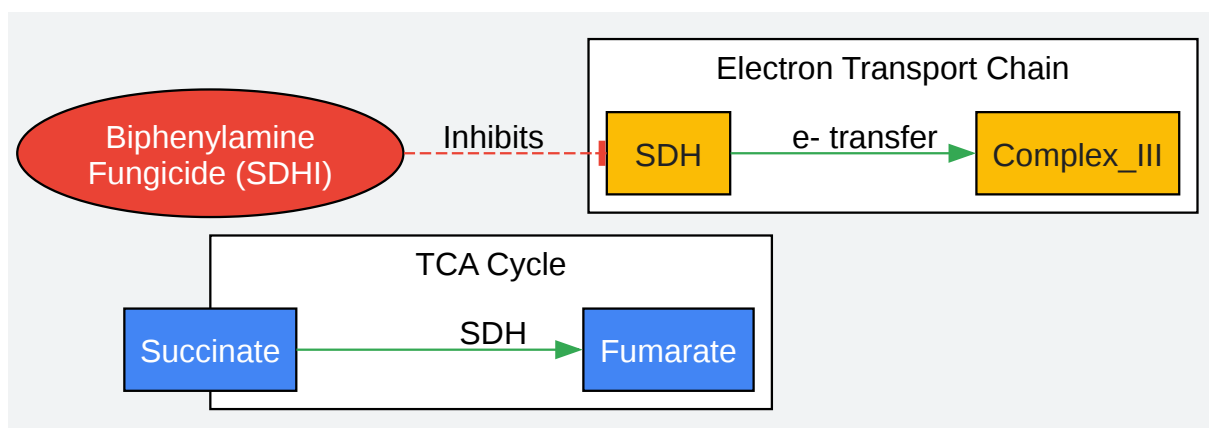

[Click to download full resolution via product page](#)

Caption: Inhibition of the mitochondrial electron transport chain by biphenylamine-based SDHI fungicides.

CYP51 Inhibition

Another important mechanism of action for some fungicidal compounds containing biphenyl moieties is the inhibition of Lanosterol 14 α -demethylase (CYP51).[7] This enzyme is crucial for the biosynthesis of ergosterol, a vital component of fungal cell membranes. Inhibition of CYP51 leads to the depletion of ergosterol and the accumulation of toxic sterol intermediates, which disrupts membrane integrity and function, ultimately inhibiting fungal growth.[8][9]

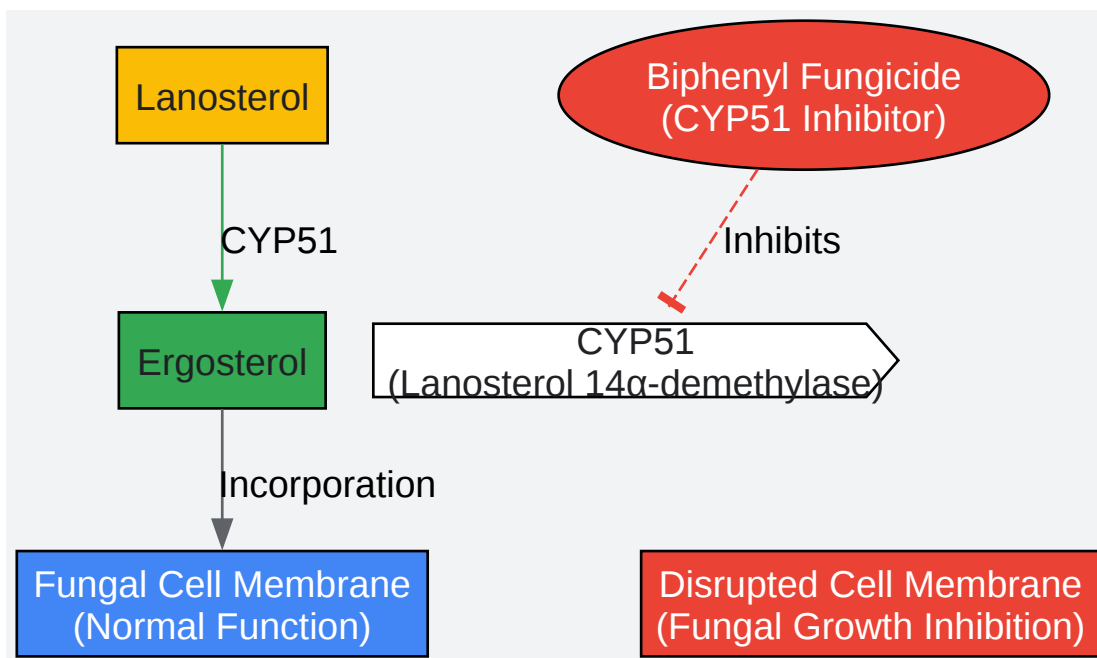

[Click to download full resolution via product page](#)

Caption: Mechanism of action of biphenyl-containing fungicides that inhibit the CYP51 enzyme.

Synthetic Strategies and Logical Relationships

The synthesis of diverse biphenylamine fungicides relies on key chemical transformations. The choice of synthetic route often depends on the desired substitution patterns and the availability of starting materials.

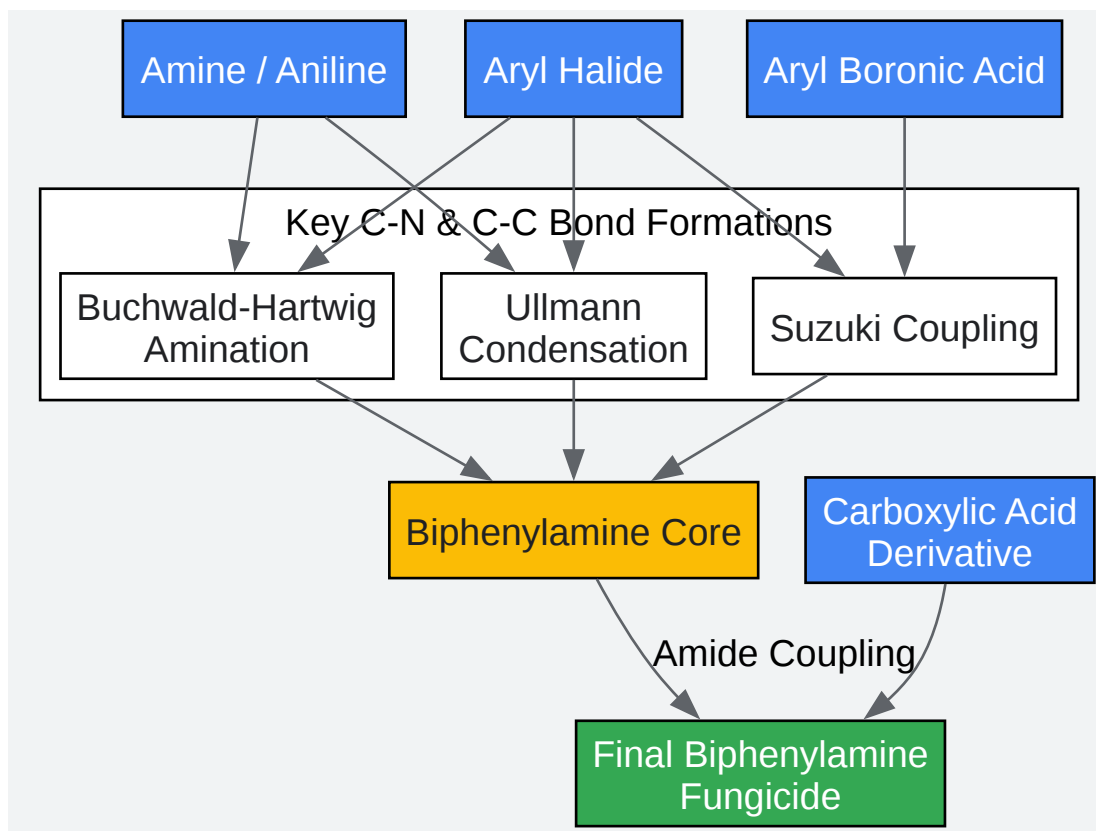

[Click to download full resolution via product page](#)

Caption: Common synthetic pathways for the construction of biphenylamine-based fungicides.

The structure-activity relationship (SAR) studies reveal that the fungicidal activity is highly dependent on the electronic and steric properties of the substituents. For instance, in many SDHI fungicides, the biphenylamine moiety serves as a crucial anchor to the enzyme's active site, while modifications on the carboxamide portion can fine-tune the activity spectrum and potency. The presence of electron-withdrawing groups, such as halogens or trifluoromethyl groups, on the biphenyl rings often enhances fungicidal activity.

This guide provides a foundational overview for the comparative analysis of biphenylamines in fungicide synthesis. Further in-depth research into specific derivatives and their biological activities will undoubtedly pave the way for the discovery of more effective and sustainable solutions for crop protection.

Need Custom Synthesis?

BenchChem offers custom synthesis for rare earth carbides and specific isotopic labeling.

Email: info@benchchem.com or [Request Quote Online](#).

References

- 1. Design, Synthesis and Fungicidal Activity of N-(thiophen-2-yl) Nicotinamide Derivatives - PMC [[pmc.ncbi.nlm.nih.gov](https://pubmed.ncbi.nlm.nih.gov)]
- 2. pubs.acs.org [pubs.acs.org]
- 3. Antifungal activity of compound 1<i>S</i>,2<i>R</i>-((3-bromophenethyl)amino)-<i>N</i>- (4-chloro-2-trifluoromethylphenyl) cyclohexane-1-sulfonamide against <i>Botrytis cinerea</i> and its mode of action [nyxxb.cn]
- 4. WO2021014437A1 - Process for the preparation of biphenylamines - Google Patents [patents.google.com]
- 5. nzpps.org [nzpps.org]
- 6. mdpi.com [mdpi.com]
- 7. Targeted Genome Mining Reveals the Biosynthetic Gene Clusters of Natural Product CYP51 Inhibitors - PMC [[pmc.ncbi.nlm.nih.gov](https://pubmed.ncbi.nlm.nih.gov)]
- 8. Fungal-specific Cyp51 inhibitor VT-1598 demonstrates in vitro activity against Candida and Cryptococcus species, endemic fungi, including Coccidioides species, Aspergillus species and Rhizopus arrhizus - PubMed [pubmed.ncbi.nlm.nih.gov]
- 9. Discovery of biphenyl imidazole derivatives as potent antifungal agents: Design, synthesis, and structure-activity relationship studies - PubMed [pubmed.ncbi.nlm.nih.gov]
- To cite this document: BenchChem. [A Comparative Analysis of Biphenylamines in the Synthesis of Novel Fungicides]. BenchChem, [2025]. [Online PDF]. Available at: [<https://www.benchchem.com/product/b196108#comparative-study-of-different-biphenylamines-in-fungicide-synthesis>]

Disclaimer & Data Validity:

The information provided in this document is for Research Use Only (RUO) and is strictly not intended for diagnostic or therapeutic procedures. While BenchChem strives to provide

accurate protocols, we make no warranties, express or implied, regarding the fitness of this product for every specific experimental setup.

Technical Support: The protocols provided are for reference purposes. Unsure if this reagent suits your experiment? [[Contact our Ph.D. Support Team for a compatibility check](#)]

Need Industrial/Bulk Grade? [Request Custom Synthesis Quote](#)

BenchChem

Our mission is to be the trusted global source of essential and advanced chemicals, empowering scientists and researchers to drive progress in science and industry.

Contact

Address: 3281 E Guasti Rd

Ontario, CA 91761, United States

Phone: (601) 213-4426

Email: info@benchchem.com