

Application of Calcitriol Impurity D in ANDA Filing: Detailed Application Notes and Protocols

Author: BenchChem Technical Support Team. **Date:** April 2026

Compound of Interest

Compound Name: Calcitriol Impurities D

CAS No.: 103656-40-2

Cat. No.: B195312

[Get Quote](#)

For Researchers, Scientists, and Drug Development Professionals

Introduction

Calcitriol, the biologically active form of vitamin D3, is a critical therapeutic agent for managing conditions related to calcium deficiency and metabolic bone disease. For generic drug manufacturers seeking Abbreviated New Drug Application (ANDA) approval for Calcitriol formulations, demonstrating control over impurities is a paramount regulatory requirement. This document provides detailed application notes and protocols focusing on Calcitriol Impurity D, a known related substance, to support ANDA filings.

Calcitriol Impurity D has been identified as 24-Homo-1,25-dihydroxyvitamin D3. Its presence in the final drug product must be monitored and controlled within acceptable limits to ensure the safety and efficacy of the generic product. These notes are intended to guide researchers and drug development professionals through the necessary analytical procedures and regulatory considerations.

Regulatory Framework for Impurity Control in ANDAs

The U.S. Food and Drug Administration (FDA) provides clear guidance on the control of impurities in generic drug products.^{[1][2][3]} Key principles for ANDA submissions include:

- **Impurity Profiling:** A comprehensive impurity profile of the generic drug product must be established and compared with that of the Reference Listed Drug (RLD).
- **Identification and Qualification:** Impurities present at levels above the identification threshold must be identified. Qualification is the process of gathering and evaluating data to establish the biological safety of an individual impurity at the observed level.^{[2][3]}
- **Acceptance Criteria:** Acceptance criteria for impurities are established based on pharmacopeial standards, levels observed in the RLD, and qualification thresholds outlined in ICH guidelines.^{[1][2]}

The qualification threshold for an impurity is determined by the maximum daily dose (MDD) of the drug substance. For potent drugs like Calcitriol, with a low daily dose, the thresholds for identification and qualification of impurities are typically low.

Characterization of Calcitriol Impurity D

A summary of the key identification details for Calcitriol and its Impurity D is provided in the table below for easy reference.

Compound	Chemical Name	CAS Number	Molecular Formula	Molecular Weight (g/mol)
Calcitriol	(1R,3S,5Z)-4-Methylene-5-[(2E)-2-[(1R,3aS,7aR)-octahydro-7a-methyl-1-[(2R)-6-hydroxy-6-methylheptan-2-yl]-4H-inden-4-ylidene]ethylidene]-1,3-cyclohexanediol	32222-06-3	C ₂₇ H ₄₄ O ₃	416.64
Calcitriol Impurity D	24-Homo-1,25-dihydroxyvitamin D ₃	103656-40-2	C ₂₈ H ₄₆ O ₃	430.66

Analytical Protocol for Calcitriol Impurity D

The following High-Performance Liquid Chromatography (HPLC) method is designed for the separation and quantification of Calcitriol Impurity D from Calcitriol in drug substances and finished products. This method is based on established principles for the analysis of vitamin D analogs and should be validated according to ICH Q2(R1) guidelines before implementation.

Chromatographic Conditions

Parameter	Specification
Column	C18, 2.7 μ m, 4.6 x 150 mm (or equivalent)
Mobile Phase A	10% Acetonitrile in Water
Mobile Phase B	Acetonitrile
Gradient Program	Time (min)
0	
15	
20	
21	
25	
Flow Rate	1.2 mL/min
Column Temperature	35°C
Detection Wavelength	265 nm
Injection Volume	10 μ L

Preparation of Solutions

- Diluent: Methanol or a mixture of Acetonitrile and Water.
- Standard Preparation: Prepare a standard solution of Calcitriol and a separate standard solution of Calcitriol Impurity D in the diluent. A mixed standard solution can also be prepared to verify resolution.
- Sample Preparation: The preparation method will depend on the dosage form (e.g., soft gelatin capsules, oral solution, injection). For capsules, the contents should be extracted with a suitable solvent. For solutions, a direct dilution may be appropriate. All sample preparations should be protected from light.

Experimental Workflow for Impurity Analysis

The following diagram illustrates the general workflow for the analysis of Calcitriol Impurity D in an ANDA submission.

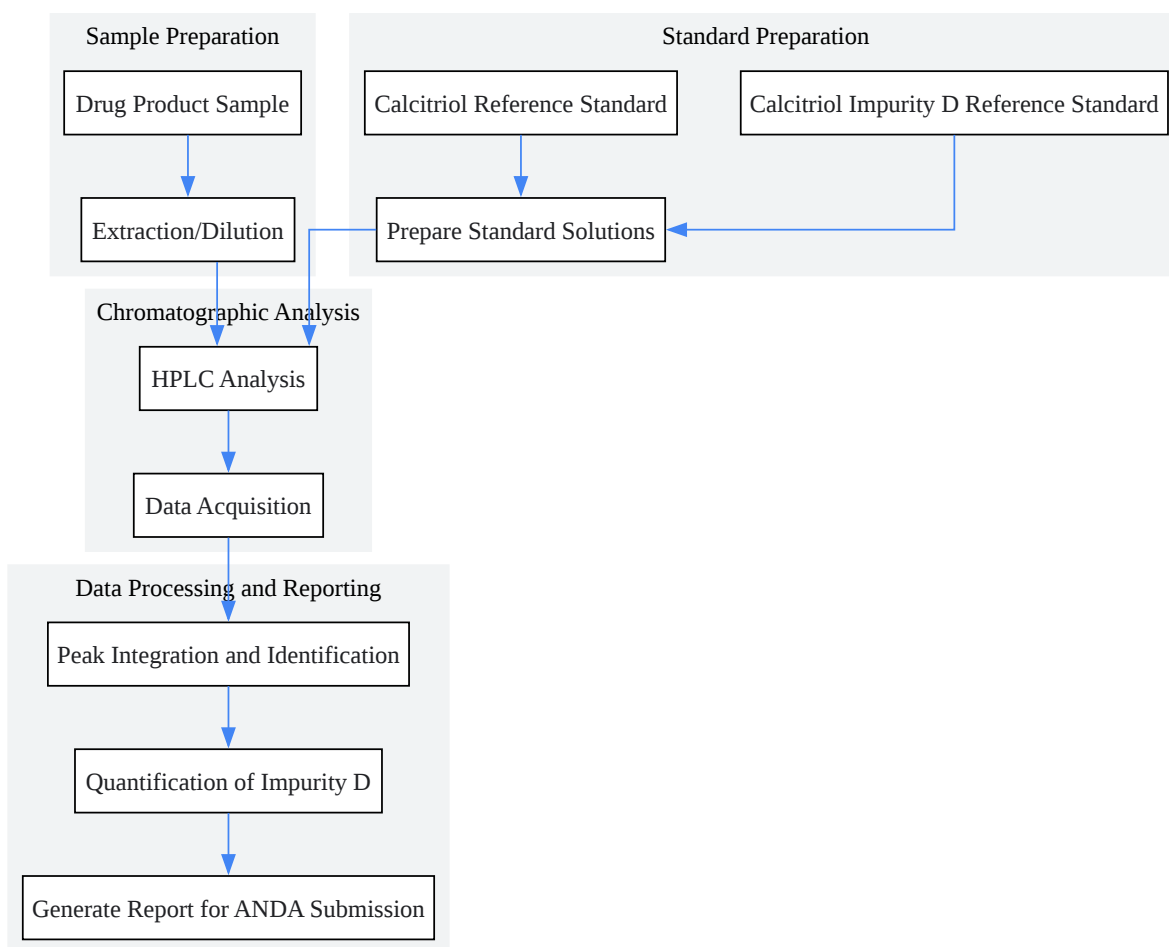

[Click to download full resolution via product page](#)

Workflow for Calcitriol Impurity D Analysis

Formation Pathway of Calcitriol Impurity D

Calcitriol Impurity D, 24-Homo-1,25-dihydroxyvitamin D₃, is a process-related impurity that can arise during the synthesis of Calcitriol. Its formation is typically associated with the starting materials or intermediates used in the synthetic route. The diagram below illustrates a plausible point of introduction for this impurity.

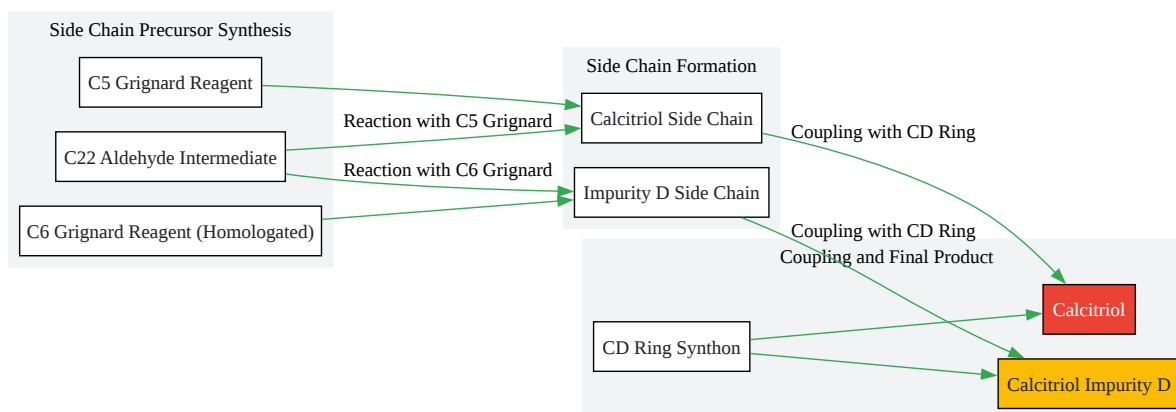

[Click to download full resolution via product page](#)

Potential Synthetic Origin of Calcitriol Impurity D

Data Presentation and Acceptance Criteria

All quantitative data regarding Calcitriol Impurity D should be summarized in a clear and concise tabular format within the ANDA submission. The acceptance criteria for this impurity should be established based on the principles outlined in FDA guidance.

Example Table for Reporting Impurity Levels

Batch Number	Calcitriol Assay (%)	Calcitriol Impurity D (%)	Total Impurities (%)
Generic Batch 1	99.5	0.12	0.45
Generic Batch 2	99.6	0.11	0.42
Generic Batch 3	99.4	0.13	0.48
RLD Batch 1	99.7	0.10	0.39
RLD Batch 2	99.6	0.12	0.41

Establishing Acceptance Criteria

The acceptance criterion for a specified, identified impurity like Calcitriol Impurity D in an ANDA should be set no higher than the level observed in the RLD. If the level in the generic product is higher, additional qualification data may be required. For a drug with a maximum daily dose of less than 2g, the qualification threshold is typically 0.15%. However, for potent drugs like Calcitriol, a lower, more stringent limit may be expected by regulatory agencies. A thorough justification for the proposed acceptance criterion, supported by batch analysis data from both the generic and RLD products, is essential.

Conclusion

The successful filing of an ANDA for a Calcitriol product hinges on the thorough characterization and control of impurities. This document provides a framework for addressing Calcitriol Impurity D, from its identification and analytical determination to the establishment of appropriate acceptance criteria. By following these guidelines and protocols, and by maintaining a strong scientific rationale for all analytical and control strategies, applicants can build a robust submission package that meets regulatory expectations.

Need Custom Synthesis?

BenchChem offers custom synthesis for rare earth carbides and specific isotopic labeling.

Email: info@benchchem.com or [Request Quote Online](#).

References

- [1. Validated stability-indicating HPLC method for paricalcitol in pharmaceutical dosage form according to ICH guidelines: application to stability studies - PubMed \[pubmed.ncbi.nlm.nih.gov\]](#)
- [2. fda.gov \[fda.gov\]](#)
- [3. fda.gov \[fda.gov\]](#)
- To cite this document: BenchChem. [Application of Calcitriol Impurity D in ANDA Filing: Detailed Application Notes and Protocols]. BenchChem, [2026]. [Online PDF]. Available at: [\[https://www.benchchem.com/product/b195312/docs#application-of-calcitriol-impurity-d-in-anda-filing-detailed-application-notes-and-protocols\]](https://www.benchchem.com/product/b195312/docs#application-of-calcitriol-impurity-d-in-anda-filing-detailed-application-notes-and-protocols)

Disclaimer & Data Validity:

The information provided in this document is for Research Use Only (RUO) and is strictly not intended for diagnostic or therapeutic procedures. While BenchChem strives to provide accurate protocols, we make no warranties, express or implied, regarding the fitness of this product for every specific experimental setup.

Technical Support: The protocols provided are for reference purposes. Unsure if this reagent suits your experiment?

Need Industrial/Bulk Grade? [Request Custom Synthesis Quote](#)

BenchChem

Our mission is to be the trusted global source of essential and advanced chemicals, empowering scientists and researchers to drive progress in science and industry.

Contact

Address: 3281 E Guasti Rd

Ontario, CA 91761, United States

Phone: (601) 213-4426

Email: info@benchchem.com

Contact our Ph.D. Support Team for a compatibility check