

Cefamandole MIC Reproducibility: A Technical Guide to Media Selection and Protocol Standardization

Author: BenchChem Technical Support Team. **Date:** May 2026

Compound of Interest

Compound Name: *C18H18N6NaO5S2*

CAS No.: 30034-03-8

Cat. No.: B193749

[Get Quote](#)

Executive Summary

Reproducibility in Minimum Inhibitory Concentration (MIC) testing for Cefamandole (a second-generation cephalosporin) is frequently compromised by three specific variables: protein binding affinity, chemical instability, and the inoculum effect. Unlike stable aminoglycosides or fluoroquinolones, Cefamandole's in vitro activity fluctuates significantly depending on the protein content and pH of the culture media.

This guide provides a comparative analysis of Cefamandole performance across standard and enriched media, offering a self-validating protocol to minimize inter-lab variability.

Mechanism & The Reproducibility Challenge

Cefamandole exerts bactericidal activity by binding to Penicillin-Binding Proteins (PBPs), inhibiting peptidoglycan synthesis. However, its physicochemical properties introduce unique challenges for reproducibility:

- High Protein Binding (~70–80%): In media supplemented with serum or blood (e.g., for fastidious organisms), free drug concentration drops, artificially elevating MIC values compared to cation-adjusted Mueller-Hinton Broth (CAMHB).
- Beta-Lactam Instability: Cefamandole nafate hydrolyzes rapidly. Stock solutions and media sitting for >4 hours at room temperature can suffer significant potency loss, leading to "false resistance."
- Inoculum Effect: Cefamandole is susceptible to enzymatic degradation by beta-lactamases. Higher bacterial loads (CFU/mL) produce enough basal enzyme to degrade the drug before inhibition occurs, shifting MICs by 4-8 fold.

Comparative Analysis: Media Impact on MIC

The following data summarizes the expected shifts in MIC values for *Staphylococcus aureus* (MSSA) and *Escherichia coli* when deviating from the standard Cation-Adjusted Mueller-Hinton Broth (CAMHB).

Table 1: Representative Cefamandole MIC Shifts by Media Type

Media Type	Composition Characteristics	Impact on Cefamandole MIC	Mechanism of Deviation
CAMHB (Standard)	Low protein, Ca ²⁺ /Mg ²⁺ adjusted	Baseline (Reference)	Optimized for free-drug availability.
MHB + 5% Human Serum	High albumin content	Increase (2x - 4x)	High protein binding (70-80%) sequesters active drug.
Brain Heart Infusion (BHI)	High nutrient, undefined peptides	Variable / Slight Increase	Enhanced growth rates can trigger the "inoculum effect" faster than MHB.
Acidic Media (pH < 6.8)	Low pH	Increase (Potency Loss)	Acid-catalyzed hydrolysis of the beta-lactam ring reduces active concentration.
Iso-Sensitest Broth	Defined semi-synthetic	Equivalent	Generally comparable to CAMHB; fewer undefined antagonists.



Technical Note: For S. aureus (MRSA), Cefamandole may show low in vitro MICs in CAMHB but fails in vivo. This discrepancy is exacerbated in high-salt media where heteroresistance is expressed more strongly.

Visualizing the Variables

The following diagram illustrates the causal relationships between media components and Cefamandole activity.

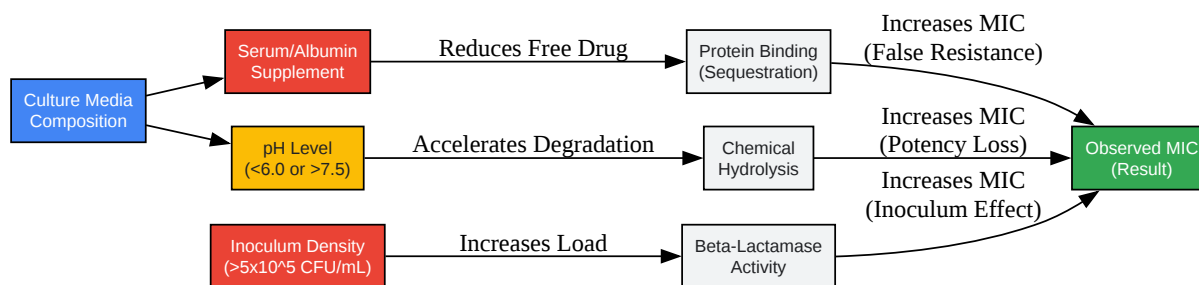

[Click to download full resolution via product page](#)

Figure 1: Causal factors influencing Cefamandole MIC values. Red nodes indicate high-risk variables.

Protocol: The Self-Validating System

To ensure reproducibility, this protocol integrates specific "Stop/Go" checkpoints.

Phase 1: Preparation (Critical Timing)

- Reagent: Cefamandole Nafate or Sodium salt (Potency corrected).
- Solvent: Phosphate Buffer pH 6.0 (Preferred over water for stability).
- Media: Cation-Adjusted Mueller-Hinton Broth (CAMHB).[1]

Step-by-Step Workflow:

- Stock Solution Prep (Time T=0):
 - Dissolve Cefamandole powder.
 - Checkpoint: Do NOT store stock solution. Use immediately or freeze at -70°C. Cefamandole loses >10% potency within 4 hours at room temperature.
- Media pH Validation:

- Measure CAMHB pH at room temperature.
- Requirement: Must be 7.2 – 7.4. If pH < 7.0, Cefamandole degradation accelerates.
- Inoculum Standardization:
 - Prepare 0.5 McFarland suspension directly from overnight culture.
 - Dilute 1:100 in CAMHB to achieve final well concentration of
CFU/mL.
 - Validation: Plate a sample of the inoculum to verify count. If count >
CFU/mL, repeat. (High inoculum artificially raises Cefamandole MIC).

Phase 2: Execution & Readout

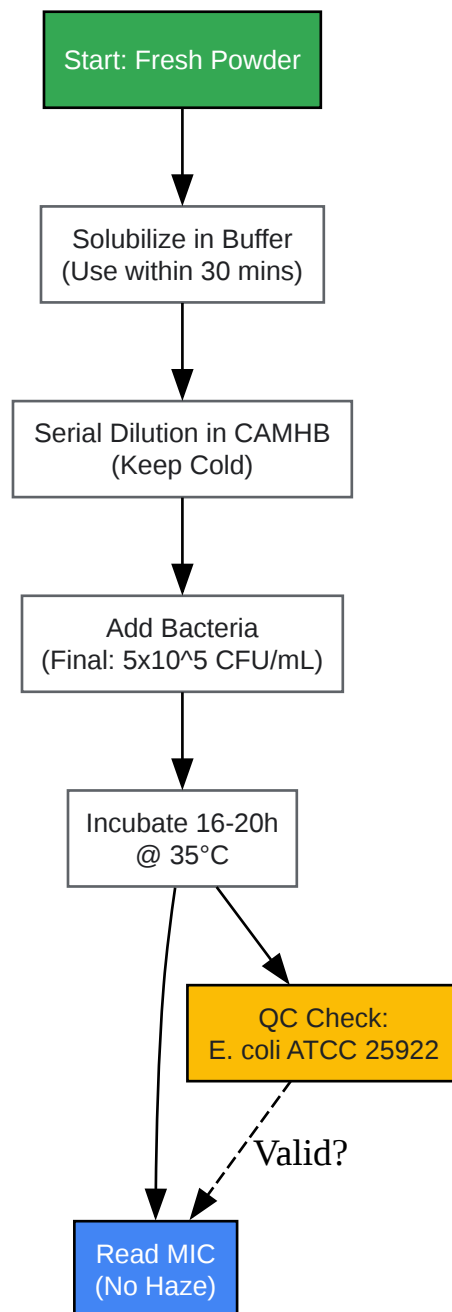

[Click to download full resolution via product page](#)

Figure 2: Optimized Cefamandole MIC workflow emphasizing time-sensitivity.

Troubleshooting & Validation

If your MIC values are inconsistent, check these parameters first:

- Issue: MIC values are consistently 2-fold higher than reference.

- Root Cause: Likely degradation of antibiotic stock. Did you use a stored frozen stock that was thawed and refrozen?
- Fix: Always prepare fresh or use single-use aliquots frozen at -70°C.
- Issue: "Trailing" growth (haze) in inhibition wells.
 - Root Cause: Inoculum too high (Inoculum effect).
 - Fix: Verify colony counts. Ensure final well concentration is strictly CFU/mL.
- Issue: Comparison with literature fails for blood-supplemented media.
 - Root Cause: Protein binding.[\[2\]](#)[\[3\]](#)[\[4\]](#)
 - Fix: You cannot directly compare MICs from CAMHB to Blood/Serum broth. Report the specific media composition explicitly.

References

- Clinical and Laboratory Standards Institute (CLSI). (2025).[\[1\]](#) M07: Methods for Dilution Antimicrobial Susceptibility Tests for Bacteria That Grow Aerobically. [\[Link\]](#)
- European Committee on Antimicrobial Susceptibility Testing (EUCAST). (2024). Media preparation for MIC testing. [\[Link\]](#)
- Neu, H. C. (1978).[\[2\]](#) Comparison of the pharmacokinetics of cefamandole and other cephalosporin compounds. Journal of Infectious Diseases. (Highlighting 70-80% protein binding). [\[Link\]](#)
- National Institutes of Health (NIH). (2025). Compatibility and stability of seven selected cephalosporin antibiotics. (Data on 4-hour stability window). [\[Link\]](#)
- Zeitlinger, M., et al. (2011). Effect of Protein Binding on the Pharmacological Activity of Highly Bound Antibiotics. Antimicrobial Agents and Chemotherapy.[\[4\]](#)[\[5\]](#)[\[6\]](#)[\[7\]](#)[\[8\]](#)[\[9\]](#) [\[Link\]](#)

Need Custom Synthesis?

BenchChem offers custom synthesis for rare earth carbides and specific isotopic labeling.

Email: info@benchchem.com or [Request Quote Online](#).

Sources

- 1. CLSI and EUCAST Release New Guidance on Modifications to Antimicrobial Susceptibility Testing [clsi.org]
- 2. Comparison of the pharmacokinetics of cefamandole and other cephalosporin compounds - PubMed [pubmed.ncbi.nlm.nih.gov]
- 3. Effect of protein binding in serum on therapeutic efficacy of cephem antibiotics - PMC [pmc.ncbi.nlm.nih.gov]
- 4. Effect of Protein Binding on the Pharmacological Activity of Highly Bound Antibiotics - PMC [pmc.ncbi.nlm.nih.gov]
- 5. Comparison of Clinical Laboratory Standards Institute and European Committee on Antimicrobial Susceptibility Testing guidelines for the interpretation of antibiotic susceptibility at a University teaching hospital in Nairobi, Kenya: a cross-sectional study - PMC [pmc.ncbi.nlm.nih.gov]
- 6. researchgate.net [researchgate.net]
- 7. Comparison of daptomycin Etest MICs on Mueller Hinton, IsoSensitest and brain heart infusion agars from Europe against 20 Staphylococcus aureus isolates - PubMed [pubmed.ncbi.nlm.nih.gov]
- 8. Cefamandole: antimicrobial activity in vitro of a new cephalosporin - PubMed [pubmed.ncbi.nlm.nih.gov]
- 9. Effect of protein binding on the pharmacological activity of highly bound antibiotics - PubMed [pubmed.ncbi.nlm.nih.gov]
- To cite this document: BenchChem. [Cefamandole MIC Reproducibility: A Technical Guide to Media Selection and Protocol Standardization]. BenchChem, [2026]. [Online PDF]. Available at: [<https://www.benchchem.com/product/b193749/docs#cefamandole-mic-reproducibility-a-technical-guide-to-media-selection-and-protocol-standardization>]

Disclaimer & Data Validity:

The information provided in this document is for Research Use Only (RUO) and is strictly not intended for diagnostic or therapeutic procedures. While BenchChem strives to provide accurate protocols, we make no warranties, express or implied, regarding the fitness of this product for every specific experimental setup.

Technical Support: The protocols provided are for reference purposes. Unsure if this reagent suits your experiment?

Need Industrial/Bulk Grade? [Request Custom Synthesis Quote](#)

BenchChem

Our mission is to be the trusted global source of essential and advanced chemicals, empowering scientists and researchers to drive progress in science and industry.

Contact

Address: 3281 E Guasti Rd
Ontario, CA 91761, United States
Phone: (601) 213-4426
Email: info@benchchem.com

[Contact our Ph.D. Support Team for a compatibility check](#)