

Technical Support Center: Fluorination of 3-Methoxy-5-Methylphenol

Author: BenchChem Technical Support Team. **Date:** May 2026

Compound of Interest

Compound Name: *1-Fluoro-3-methoxy-5-methylbenzene*

CAS No.: *160911-11-5*

Cat. No.: *B190226*

[Get Quote](#)

Welcome to the technical support center for the fluorination of 3-methoxy-5-methylphenol. This guide is designed for researchers, scientists, and drug development professionals to navigate the common challenges encountered during this specific electrophilic fluorination reaction.

Frequently Asked Questions (FAQs)

Q1: Why is the fluorination of 3-methoxy-5-methylphenol challenging?

A1: 3-methoxy-5-methylphenol is an electron-rich aromatic compound. The methoxy (-OCH₃) and methyl (-CH₃) groups are activating, making the ring highly susceptible to electrophilic attack. However, this high reactivity can also lead to several challenges:

- **Low Regioselectivity:** The activating groups direct fluorination to multiple positions (ortho and para to each group), potentially leading to a mixture of isomers (2-fluoro, 4-fluoro, and 6-fluoro derivatives).
- **Over-reaction:** The activated ring can undergo further reactions, such as di-fluorination or oxidation.

- Side Reactions: Electron-rich phenols are prone to oxidation, which can lead to the formation of quinone-like byproducts, especially with powerful oxidizing fluorinating agents like Selectfluor™.^{[1][2]}
- Dearomatization: In some cases, dearomatization of the phenol ring can occur, leading to fluorinated cyclohexadienones.

Q2: What are the most common fluorinating agents for this type of substrate?

A2: The most common electrophilic fluorinating agents for electron-rich phenols are N-fluoro reagents. These include:

- Selectfluor™ (F-TEDA-BF₄): A highly reactive and versatile reagent, but its high oxidizing potential can lead to side reactions with sensitive substrates.^{[1][2][3]}
- N-Fluorobenzenesulfonimide (NFSI): Generally considered a milder alternative to Selectfluor™, which can sometimes offer better selectivity and fewer oxidative side products.

Q3: Which positions on the 3-methoxy-5-methylphenol ring are most likely to be fluorinated?

A3: Based on the directing effects of the methoxy and methyl groups, the most likely positions for electrophilic fluorination are C2, C4, and C6. The hydroxyl group is a strong ortho, para-director, as is the methoxy group. The methyl group is a weaker ortho, para-director. Therefore, the positions ortho and para to the hydroxyl and methoxy groups are the most activated.

Q4: Can I use a base to improve the reaction?

A4: The use of a base in electrophilic fluorination of phenols is generally not recommended. The reaction typically proceeds under neutral or slightly acidic conditions. Adding a base can deprotonate the phenol to form a phenoxide, which is even more electron-rich and can lead to uncontrolled reactions, polymerization, or reaction with the fluorinating agent itself.

Troubleshooting Guides

Problem 1: Low Yield of the Desired Monofluorinated Product

Possible Causes:

- Incomplete reaction.
- Formation of multiple isomers that are difficult to separate.
- Degradation of the starting material or product.
- Formation of undetected, soluble byproducts.

Solutions:

- **Reaction Time and Temperature:** Monitor the reaction progress by TLC or LC-MS to determine the optimal reaction time. If the reaction is sluggish, a slight increase in temperature may be beneficial. However, be cautious as higher temperatures can also promote side reactions.
- **Solvent Choice:** The polarity of the solvent can significantly influence the reaction rate and selectivity. Acetonitrile (CH_3CN) is a common choice. Experimenting with other solvents like dichloromethane (CH_2Cl_2) or a less polar solvent like toluene may improve the outcome.
- **Fluorinating Agent:** If using Selectfluor™ results in low yields due to degradation, switching to a milder agent like NFSI may be advantageous.
- **Stoichiometry:** Ensure the correct stoichiometry of the fluorinating agent. An excess may lead to over-reaction, while an insufficient amount will result in incomplete conversion. Start with 1.0 to 1.2 equivalents of the fluorinating agent.

Problem 2: Poor Regioselectivity (Formation of Multiple Isomers)

Possible Causes:

- Similar activation of multiple ring positions (C2, C4, C6) by the -OH, -OCH₃, and -CH₃ groups.

Solutions:

- **Lower Reaction Temperature:** Running the reaction at a lower temperature (e.g., 0 °C or even -20 °C) can sometimes enhance the kinetic selectivity for one isomer over others.
- **Solvent Effects:** The solvent can influence the regioselectivity by solvating the transition states differently. A systematic screening of solvents is recommended.
- **Bulky Fluorinating Agents:** While less common, employing a bulkier fluorinating agent could potentially favor attack at the less sterically hindered positions.
- **Protecting Group Strategy:** Although more synthetically demanding, protecting the hydroxyl group as a bulkier ether could influence the regioselectivity of the fluorination on the aromatic ring. The protecting group would need to be removed in a subsequent step.

Problem 3: Formation of Dark-Colored Byproducts (Indicative of Oxidation)

Possible Causes:

- Oxidation of the electron-rich phenol by the fluorinating agent, particularly with potent oxidants like Selectfluor™.

Solutions:

- **Use a Milder Fluorinating Agent:** Switch from Selectfluor™ to NFSI, which has a lower oxidizing potential.
- **Control Reaction Temperature:** Keep the reaction temperature as low as possible to minimize oxidative side reactions.
- **Inert Atmosphere:** While not always necessary for N-F reagents, running the reaction under an inert atmosphere (e.g., nitrogen or argon) can help to prevent oxidation from atmospheric oxygen, which might be promoted by radical intermediates.
- **Scavengers:** In some cases, the addition of radical scavengers can suppress unwanted side reactions, although this may also inhibit the desired fluorination if it proceeds via a single-electron transfer (SET) mechanism.

Data Presentation

Table 1: Comparison of Reaction Conditions for the Fluorination of Substituted Phenols

| Substrate | Fluorinating Agent | Solvent | Temperature (°C) | Time (h) | Yield of Monofluorinated Product(s) (%) | Reference |
|--------------------|------------------------|--------------------------|------------------|----------|---|-----------|
| Phenol | F-TEDA-BF ₄ | H ₂ O | 20 | 2 | 41 (o:p ratio ~1:1) | [4] |
| 4-tert-Butylphenol | F-TEDA-BF ₄ | [bmim][BF ₄] | 70 | 4 | 37 (ortho) + 28 (ipso) | [1] |
| 1-Naphthol | F-TEDA-BF ₄ | EtOH | 40 | 24 | 52 (total) | [3] |
| Resorcinol | F-TEDA-BF ₄ | H ₂ O | 20 | 0.5 | 65 (4-fluoro) + 15 (4,6-difluoro) | [4] |

Note: Data for 3-methoxy-5-methylphenol is not explicitly available in the searched literature; this table provides data for structurally related phenols to guide experimental design.

Experimental Protocols

General Protocol for Electrophilic Fluorination of 3-Methoxy-5-Methylphenol with Selectfluor™

This protocol is a general starting point and may require optimization for the specific substrate.

Materials:

- 3-Methoxy-5-methylphenol
- Selectfluor™ (F-TEDA-BF₄)

- Anhydrous acetonitrile (CH₃CN)
- Round-bottom flask
- Magnetic stirrer
- Inert atmosphere setup (optional, but recommended)

Procedure:

- To a clean, dry round-bottom flask, add 3-methoxy-5-methylphenol (1.0 eq).
- Dissolve the starting material in anhydrous acetonitrile (concentration typically 0.1-0.5 M).
- Stir the solution at room temperature (or cool to a desired temperature, e.g., 0 °C).
- In a separate container, weigh out Selectfluor™ (1.1 eq).
- Add the Selectfluor™ portion-wise to the stirred solution of the phenol over 10-15 minutes. An exothermic reaction may be observed.
- Stir the reaction mixture at the chosen temperature and monitor its progress by TLC or LC-MS.
- Upon completion (or when no further conversion is observed), quench the reaction by adding water.
- Extract the aqueous mixture with an organic solvent (e.g., ethyl acetate or dichloromethane).
- Combine the organic layers, wash with brine, dry over anhydrous sodium sulfate or magnesium sulfate, and concentrate under reduced pressure.
- Purify the crude product by column chromatography on silica gel to separate the isomers and remove byproducts.

Mandatory Visualizations

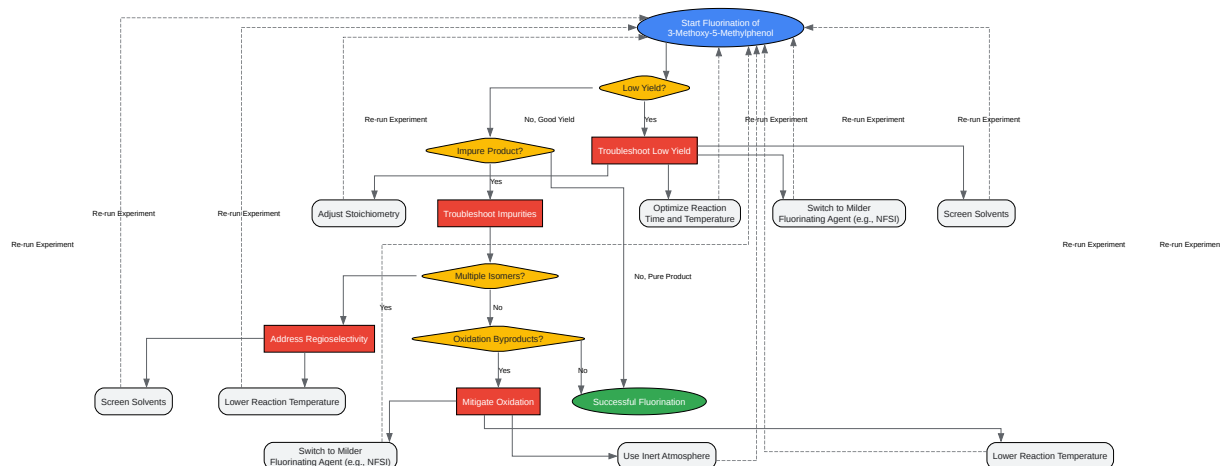

[Click to download full resolution via product page](#)

Caption: Troubleshooting workflow for the fluorination of 3-methoxy-5-methylphenol.

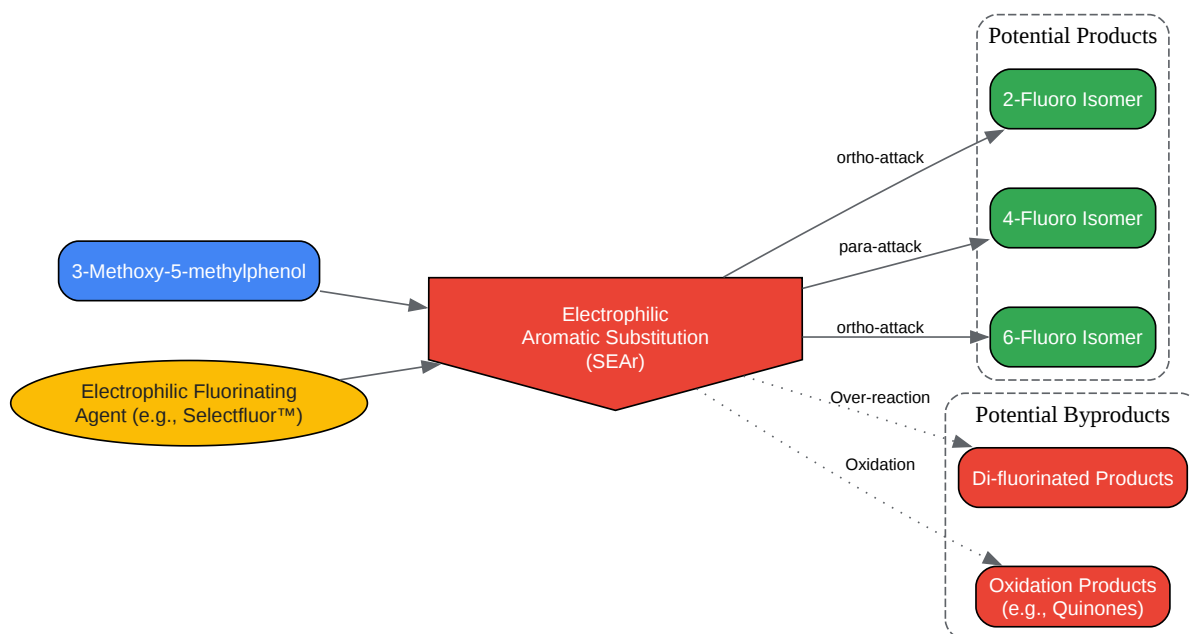

[Click to download full resolution via product page](#)

Caption: Reaction pathway for the electrophilic fluorination of 3-methoxy-5-methylphenol.

Need Custom Synthesis?

BenchChem offers custom synthesis for rare earth carbides and specific isotopic labeling.

Email: info@benchchem.com or [Request Quote Online](#).

References

- 1. Transformations of Organic Molecules with F-TEDA-BF₄ in Ionic Liquid Media - PMC [[pmc.ncbi.nlm.nih.gov](https://pubmed.ncbi.nlm.nih.gov)]

- [2. researchgate.net \[researchgate.net\]](#)
- [3. researchgate.net \[researchgate.net\]](#)
- [4. researchgate.net \[researchgate.net\]](#)
- To cite this document: BenchChem. [Technical Support Center: Fluorination of 3-Methoxy-5-Methylphenol]. BenchChem, [2026]. [Online PDF]. Available at: [\[https://www.benchchem.com/product/b190226/docs#technical-support-center-fluorination-of-3-methoxy-5-methylphenol\]](https://www.benchchem.com/product/b190226/docs#technical-support-center-fluorination-of-3-methoxy-5-methylphenol)

Disclaimer & Data Validity:

The information provided in this document is for Research Use Only (RUO) and is strictly not intended for diagnostic or therapeutic procedures. While BenchChem strives to provide accurate protocols, we make no warranties, express or implied, regarding the fitness of this product for every specific experimental setup.

Technical Support: The protocols provided are for reference purposes. Unsure if this reagent suits your experiment?

Need Industrial/Bulk Grade? [Request Custom Synthesis Quote](#)

BenchChem

Our mission is to be the trusted global source of essential and advanced chemicals, empowering scientists and researchers to drive progress in science and industry.

Contact

Address: 3281 E Guasti Rd
Ontario, CA 91761, United States
Phone: (601) 213-4426
Email: info@benchchem.com

[Contact our Ph.D. Support Team for a compatibility check](#)

