

Spectroscopic Characterization of 2-Fluoro-6-(methylthio)phenol: A Technical Guide

Author: BenchChem Technical Support Team. **Date:** May 2026

Compound of Interest

Compound Name: 2-Fluoro-6-(methylthio)phenol

CAS No.: 197149-26-1

Cat. No.: B190215

[Get Quote](#)

Introduction

2-Fluoro-6-(methylthio)phenol is a substituted aromatic compound with potential applications in medicinal chemistry and materials science. Its unique trifunctionalized structure, featuring a hydroxyl group, a fluorine atom, and a methylthio group on a benzene ring, presents a compelling case for detailed spectroscopic analysis. Understanding the spectral characteristics of this molecule is paramount for its unambiguous identification, purity assessment, and for predicting its chemical behavior in various applications.

This technical guide provides an in-depth analysis of the expected spectroscopic data for **2-Fluoro-6-(methylthio)phenol**, including Nuclear Magnetic Resonance (NMR) spectroscopy, Mass Spectrometry (MS), and Infrared (IR) Spectroscopy. While direct experimental spectra for this specific compound (CAS 197149-26-1) are not widely available in public repositories, this guide leverages established spectroscopic principles and data from closely related analogs to provide a robust, predictive framework for its characterization.^[1]

Molecular Structure and Expected Spectroscopic Features

A thorough understanding of the molecular structure is the foundation for interpreting spectroscopic data. The interplay of the electron-donating hydroxyl and methylthio groups, and the electron-withdrawing fluorine atom, will significantly influence the electronic environment of the aromatic ring and, consequently, the spectral readouts.

Nuclear Magnetic Resonance (NMR) Spectroscopy

NMR spectroscopy is arguably the most powerful tool for elucidating the structure of organic molecules in solution. For **2-Fluoro-6-(methylthio)phenol**, both ^1H and ^{13}C NMR will provide critical information about the connectivity and chemical environment of each atom.

Experimental Protocol (Predicted)

A standard approach for acquiring NMR spectra for a solid sample like **2-Fluoro-6-(methylthio)phenol** would involve:

- **Sample Preparation:** Dissolve approximately 5-10 mg of the compound in 0.5-0.7 mL of a deuterated solvent, such as deuteriochloroform (CDCl_3) or dimethyl sulfoxide- d_6 ($\text{DMSO}-d_6$). The choice of solvent can influence the chemical shift of the hydroxyl proton.
- **Instrumentation:** Utilize a high-field NMR spectrometer (e.g., 400 MHz or higher) for optimal signal dispersion and resolution.
- **^1H NMR Acquisition:** Acquire a standard one-dimensional proton spectrum. Key parameters include a sufficient number of scans for a good signal-to-noise ratio, a spectral width covering the expected chemical shift range (typically 0-12 ppm), and a relaxation delay of 1-5 seconds.
- **^{13}C NMR Acquisition:** Obtain a proton-decoupled ^{13}C spectrum. A larger number of scans will be necessary due to the lower natural abundance of the ^{13}C isotope. The spectral width should encompass the expected range for aromatic and aliphatic carbons (typically 0-200 ppm).

Predicted ^1H NMR Data

The ^1H NMR spectrum is expected to show distinct signals for the aromatic protons, the hydroxyl proton, and the methyl protons.

Proton Assignment	Predicted Chemical Shift (δ , ppm)	Predicted Multiplicity	Predicted Coupling Constant (J, Hz)
Ar-H (H3, H4, H5)	6.8 - 7.3	Multiplet	$J_{\text{H-H}} \approx 7\text{-}9$ Hz, $J_{\text{H-F}} \approx 2\text{-}5$ Hz
-OH	5.0 - 6.0 (variable)	Singlet (broad)	N/A
-SCH ₃	2.4 - 2.6	Singlet	N/A

Causality Behind Predictions:

- Aromatic Protons (Ar-H):** The three adjacent protons on the aromatic ring will exhibit complex splitting patterns due to both proton-proton (ortho and meta) and proton-fluorine couplings. Their chemical shifts are influenced by the opposing electronic effects of the substituents.
- Hydroxyl Proton (-OH):** The chemical shift of the phenolic proton is highly dependent on concentration, temperature, and solvent due to hydrogen bonding.^[2] It typically appears as a broad singlet.
- Methyl Protons (-SCH₃):** The methyl group, being attached to a sulfur atom, will appear as a sharp singlet in the upfield region, characteristic of methyl thioethers.

Predicted ^{13}C NMR Data

The proton-decoupled ^{13}C NMR spectrum will provide a signal for each unique carbon atom in the molecule.

Carbon Assignment	Predicted Chemical Shift (δ , ppm)
C-SCH ₃	15 - 25
C3, C4, C5	115 - 130
C1 (-OH)	150 - 160 (d, JC-F \approx 5-10 Hz)
C2 (-F)	155 - 165 (d, JC-F \approx 240-250 Hz)
C6 (-SCH ₃)	120 - 135

Causality Behind Predictions:

- Methyl Carbon (C-SCH₃): This aliphatic carbon will have the most upfield chemical shift.
- Aromatic Carbons (C3, C4, C5): These carbons will resonate in the typical aromatic region.
- Substituted Aromatic Carbons (C1, C2, C6): The carbons directly attached to the substituents will have their chemical shifts significantly influenced by the electronic nature of these groups. The carbon bearing the fluorine atom (C2) will exhibit a large one-bond carbon-fluorine coupling constant (¹JCF), which is a hallmark of fluorinated aromatic compounds. The carbon attached to the hydroxyl group (C1) will show a smaller two-bond coupling to fluorine (²JCF).

Diagram: Predicted ¹H NMR and ¹³C NMR Correlations for **2-Fluoro-6-(methylthio)phenol**

Caption: Predicted NMR correlations for **2-Fluoro-6-(methylthio)phenol**.

Mass Spectrometry (MS)

Mass spectrometry provides information about the molecular weight and fragmentation pattern of a compound, which can be used for identification and structural elucidation.

Experimental Protocol (Predicted)

- Ionization Method: Electron Ionization (EI) is a common technique for volatile and thermally stable compounds like phenols. Electrospray ionization (ESI) could also be used, particularly in negative ion mode to detect the deprotonated molecule [M-H]⁻.

- Mass Analyzer: A quadrupole or time-of-flight (TOF) analyzer would be suitable for determining the mass-to-charge ratio (m/z) of the resulting ions.
- Data Acquisition: The mass spectrum would be recorded over a suitable m/z range (e.g., 50-500).

Predicted Mass Spectrum Data

The molecular weight of **2-Fluoro-6-(methylthio)phenol** (C_7H_7FOS) is 158.19 g/mol [\[1\]](#)

Ion	Predicted m/z	Interpretation
$[M]^+$	158	Molecular Ion
$[M-CH_3]^+$	143	Loss of a methyl radical
$[M-SCH_3]^+$	111	Loss of a methylthio radical
$[M-CO]^+$	130	Loss of carbon monoxide

Causality Behind Predictions:

- Molecular Ion ($[M]^+$): The peak corresponding to the intact molecule is expected to be observed.
- Fragmentation: Common fragmentation pathways for phenols include the loss of a methyl group from the thioether, loss of the entire methylthio group, and the loss of carbon monoxide from the phenolic ring.

Diagram: Predicted Mass Spectrometry Fragmentation of **2-Fluoro-6-(methylthio)phenol**

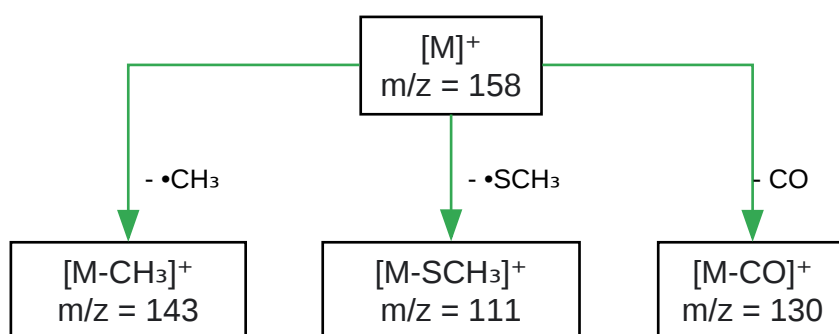

[Click to download full resolution via product page](#)

Caption: Predicted fragmentation pathways in mass spectrometry.

Infrared (IR) Spectroscopy

IR spectroscopy is used to identify the functional groups present in a molecule based on the absorption of infrared radiation at specific wavenumbers.

Experimental Protocol (Predicted)

- **Sample Preparation:** The spectrum can be obtained from a neat sample using an Attenuated Total Reflectance (ATR) accessory, or by preparing a KBr pellet containing a small amount of the compound.
- **Instrumentation:** A Fourier-Transform Infrared (FTIR) spectrometer would be used to acquire the spectrum.
- **Data Acquisition:** The spectrum is typically recorded in the range of 4000 to 400 cm^{-1} .

Predicted IR Absorption Data

Vibrational Mode	Predicted Wavenumber (cm^{-1})	Intensity
O-H stretch (hydrogen-bonded)	3200 - 3500	Strong, Broad
C-H stretch (aromatic)	3000 - 3100	Medium
C-H stretch (aliphatic)	2850 - 2960	Medium
C=C stretch (aromatic)	1450 - 1600	Medium-Strong
C-F stretch	1200 - 1250	Strong
C-O stretch (phenol)	1180 - 1260	Strong
C-S stretch	600 - 800	Weak-Medium

Causality Behind Predictions:

- O-H Stretch: The hydroxyl group will give rise to a characteristic broad and strong absorption band due to intermolecular hydrogen bonding.[3]
- C-H Stretches: The aromatic and aliphatic C-H stretching vibrations will appear in their respective characteristic regions.
- Aromatic C=C Stretches: The benzene ring will show several absorptions in the 1450-1600 cm^{-1} region.
- C-F and C-O Stretches: The carbon-fluorine and carbon-oxygen stretching vibrations will result in strong absorptions in the fingerprint region.
- C-S Stretch: The carbon-sulfur bond will have a weaker absorption at lower wavenumbers.

Conclusion

This technical guide provides a comprehensive, albeit predictive, spectroscopic analysis of **2-Fluoro-6-(methylthio)phenol**. By leveraging established principles and data from analogous compounds, we have outlined the expected ^1H NMR, ^{13}C NMR, mass spectrometry, and IR data. This information serves as a valuable resource for researchers in the synthesis, identification, and application of this and related molecules. The self-validating nature of these combined spectroscopic techniques provides a high degree of confidence in the structural assignment of **2-Fluoro-6-(methylthio)phenol**.

References

- PubChem. o-(Methylthio)phenol. [[Link](#)]
- NIST. Phenol, 2-fluoro-. [[Link](#)]
- PubChem. 2-Fluorothiophenol. [[Link](#)]
- Chemistry LibreTexts. Spectroscopy of Alcohols and Phenols. [[Link](#)]
- Doc Brown's Chemistry. infrared spectrum of phenol. [[Link](#)]

Need Custom Synthesis?

BenchChem offers custom synthesis for rare earth carbides and specific isotopic labeling.

Email: info@benchchem.com or [Request Quote Online](#).

Sources

- [1. Phenol, 2-fluoro-6-\(methylthio\)- \(9CI\) | 197149-26-1 \[chemicalbook.com\]](#)
- [2. chem.libretexts.org \[chem.libretexts.org\]](#)
- [3. infrared spectrum of phenol C6H6O C6H5OH prominent wavenumbers cm-1 detecting ? functional groups present finger print for identification of phenol image diagram doc brown's advanced organic chemistry revision notes \[docbrown.info\]](#)
- To cite this document: BenchChem. [Spectroscopic Characterization of 2-Fluoro-6-(methylthio)phenol: A Technical Guide]. BenchChem, [2026]. [Online PDF]. Available at: [\[https://www.benchchem.com/product/b190215/docs#spectroscopic-characterization-of-2-fluoro-6-methylthio-phenol-a-technical-guide\]](https://www.benchchem.com/product/b190215/docs#spectroscopic-characterization-of-2-fluoro-6-methylthio-phenol-a-technical-guide)

Disclaimer & Data Validity:

The information provided in this document is for Research Use Only (RUO) and is strictly not intended for diagnostic or therapeutic procedures. While BenchChem strives to provide accurate protocols, we make no warranties, express or implied, regarding the fitness of this product for every specific experimental setup.

Technical Support: The protocols provided are for reference purposes. Unsure if this reagent suits your experiment?

Need Industrial/Bulk Grade? [Request Custom Synthesis Quote](#)

BenchChem

Our mission is to be the trusted global source of essential and advanced chemicals, empowering scientists and researchers to drive progress in science and industry.

Contact

Address: 3281 E Guasti Rd

Ontario, CA 91761, United States

Phone: (601) 213-4426

Email: info@benchchem.com

[Contact our Ph.D. Support Team for a compatibility check](#)