

Technical Support Center: Catalyst Selection for Functionalizing 2-(Chloromethyl)quinoxaline

Author: BenchChem Technical Support Team. **Date:** May 2026

Compound of Interest

Compound Name: 2-(Chloromethyl)quinoxaline

CAS No.: 106435-53-4

Cat. No.: B019384

[Get Quote](#)

Introduction: The Versatility of the 2-(Chloromethyl)quinoxaline Scaffold

Welcome to the technical support center for the functionalization of **2-(Chloromethyl)quinoxaline**. This guide is designed for researchers, medicinal chemists, and drug development professionals who are leveraging this versatile heterocyclic building block. The quinoxaline core is a privileged scaffold found in numerous biologically active compounds, and the 2-(chloromethyl) group provides a reactive handle for introducing molecular diversity.^[1]
^[2]

However, the unique reactivity of this starting material—possessing a benzylic-like chloride adjacent to a π -deficient heteroaromatic system—presents specific challenges and opportunities in catalyst selection. This document provides in-depth, field-proven insights through a series of frequently asked questions and troubleshooting guides to ensure the success of your synthetic campaigns.

Key Scientific Consideration: Understanding the Reactivity of 2-(Chloromethyl)quinoxaline

Before selecting a catalyst, it is crucial to recognize that the C-Cl bond in **2-(chloromethyl)quinoxaline** is not a typical aryl chloride. It is a benzylic-type halide. This has profound implications for its reactivity:

- **Enhanced Reactivity:** The C-Cl bond is significantly more susceptible to oxidative addition by a low-valent metal catalyst (like Pd(0) or Ni(0)) compared to a standard aryl chloride. This often allows for milder reaction conditions.
- **Alternative Pathways:** It is also more prone to classical nucleophilic substitution (SN2 or SNAr-type) pathways, which can compete with the desired catalytic cycle, especially with strong nucleophiles or certain bases.
- **Catalyst Choice:** While palladium is the workhorse for many cross-couplings, nickel-based catalysts, known for their ability to activate less reactive bonds, can also be highly effective and sometimes offer complementary reactivity.^{[3][4]}

This guide will focus on transition-metal-catalyzed cross-coupling reactions, which provide a controlled and highly versatile method for C-C and C-X bond formation.

Catalyst & Ligand Selection Workflow

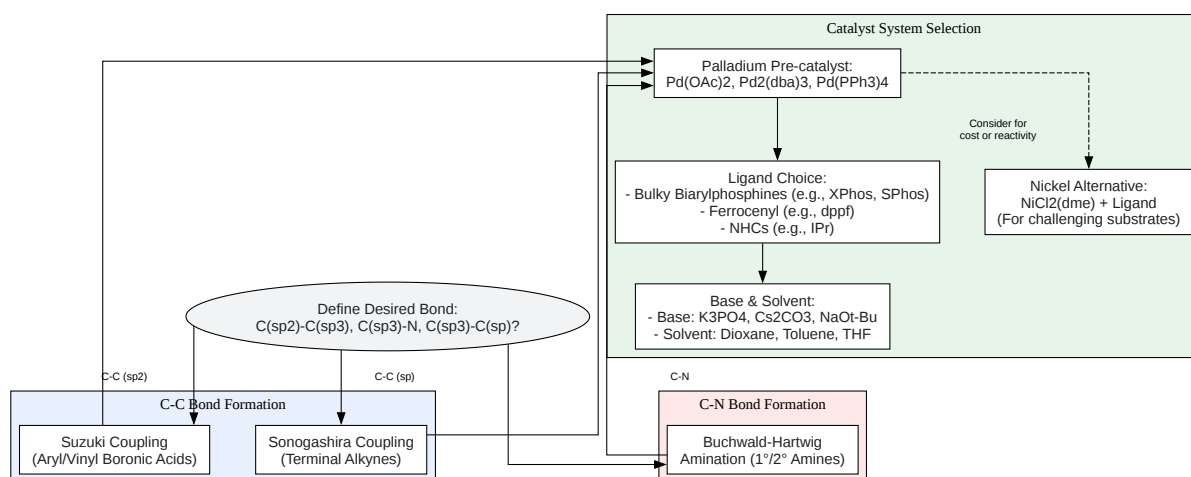

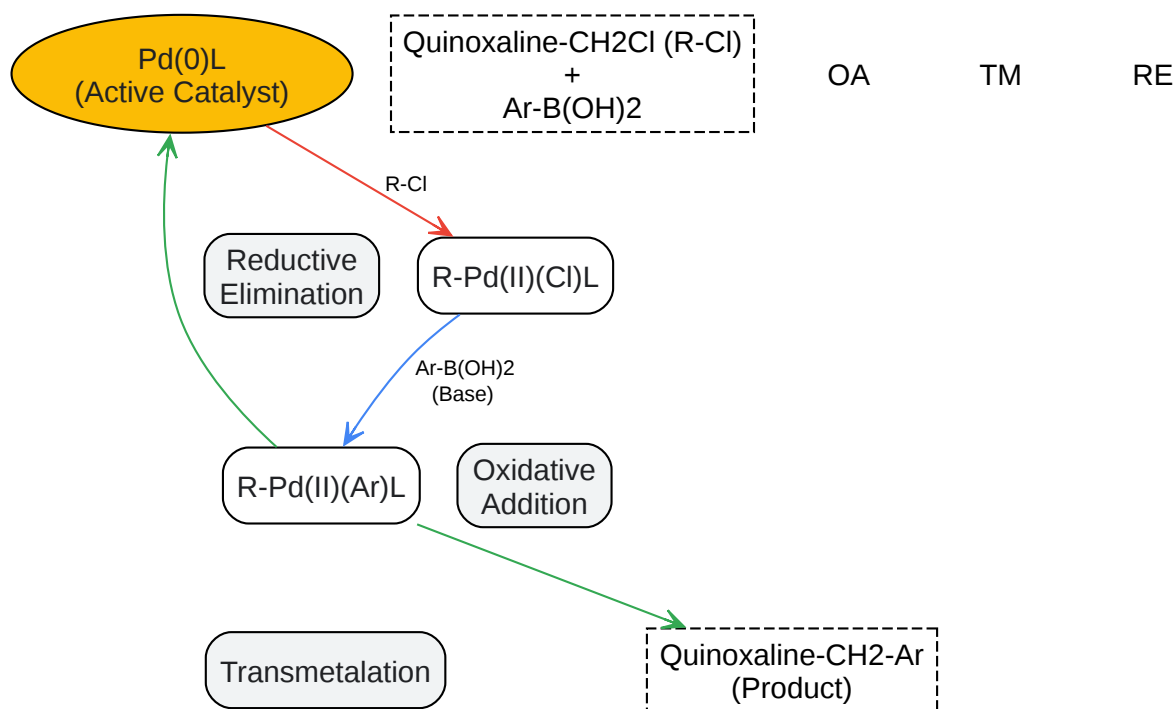

[Click to download full resolution via product page](#)

Caption: Simplified catalytic cycle for Suzuki-Miyaura coupling.

Procedure:

- Reaction Setup: To an oven-dried Schlenk tube, add the palladium precatalyst (e.g., Pd(OAc)₂, 2 mol%), the phosphine ligand (e.g., SPhos, 4 mol%), and the base (e.g., K₃PO₄, 2.0 equiv.).
- Reagent Addition: Add **2-(chloromethyl)quinoxaline** (1.0 equiv.) and the desired arylboronic acid (1.2 equiv.).
- Atmosphere Exchange: Cap the tube, then evacuate and backfill with an inert gas (Argon or Nitrogen) three times.

- Solvent Addition: Add anhydrous, degassed solvent (e.g., 1,4-Dioxane or Toluene, 0.1 M concentration) via syringe.
- Reaction: Place the sealed tube in a preheated oil bath at 80-100 °C and stir for 4-16 hours.
- Monitoring: Monitor the reaction progress by TLC or LC-MS.
- Work-up: Upon completion, cool the reaction mixture to room temperature. Dilute with ethyl acetate and wash with water and brine.
- Purification: Dry the organic layer over anhydrous Na₂SO₄, filter, and concentrate under reduced pressure. Purify the crude product by column chromatography on silica gel.

Protocol 2: Buchwald-Hartwig C-N Amination

This protocol provides a general method for coupling **2-(chloromethyl)quinoxaline** with a primary or secondary amine.

- Catalyst Preparation: In a glovebox or under an inert atmosphere, add the palladium precatalyst (e.g., Pd₂(dba)₃, 1-2 mol%), the phosphine ligand (e.g., BrettPhos, 2-4 mol%), and the base (e.g., NaOt-Bu, 1.4 equiv.) to an oven-dried Schlenk tube.
- Reagent Addition: Add **2-(chloromethyl)quinoxaline** (1.0 equiv.).
- Atmosphere and Solvent: Seal the tube, remove from the glovebox (if used), and add anhydrous, degassed solvent (e.g., Toluene) via syringe.
- Nucleophile Addition: Add the amine (1.2 equiv.) via syringe. If the amine is a solid, it should be added in step 2.
- Reaction: Place the sealed tube in a preheated oil bath at 90-110 °C and stir for 6-24 hours.
- [1]6. Monitoring & Work-up: Follow steps 6-7 from the Suzuki protocol.
- Purification: Purify the crude product by column chromatography. Note that basic alumina may be required if the amine product is sensitive to silica gel.

References

- Lv Y., Luo J., Lin M., Yue H., Dai B., He L. (2021). A visible-light photoredox-catalyzed four-component reaction for the construction of sulfone-containing quinoxalin-2(1H)-ones. *Advanced Synthesis & Catalysis*, 363, 5122–5128. [[Link](#)]
- Małkosza, M., & Wojciechowski, K. (2004). Synthesis of quinoxaline derivatives via aromatic nucleophilic substitution of hydrogen. *Organic & Biomolecular Chemistry*, 2(1), 58-64. [[Link](#)]
- Li, Y., et al. (2023). Recent Developments in Direct C–H Functionalization of Quinoxalin-2(1H)-Ones via Heterogeneous Catalysis Reactions. *Molecules*, 28(13), 5085. [[Link](#)]
- Weix, D. J. (2015). *Nickel-Catalyzed Cross-Electrophile Coupling: Methodology Development and Mechanistic Insights*. University of Wisconsin-Madison. [[Link](#)]
- Wikipedia contributors. (2024). Buchwald–Hartwig amination. Wikipedia, The Free Encyclopedia. [[Link](#)]
- Various Authors. (n.d.). *Palladium-Catalyzed Cross-Coupling Reactions in the Synthesis of Pharmaceuticals*. IntechOpen. [[Link](#)]
- Beller, M., et al. (2001). Palladium catalyst systems for cross-coupling reactions of aryl chlorides and olefins. *Chemistry*, 7(13), 2908-15. [[Link](#)]
- He, Z., et al. (2014). Synthesis of Highly Functionalized Polycyclic Quinoxaline Derivatives Using Visible-Light Photoredox Catalysis. *Angewandte Chemie International Edition*, 53(52), 14451–14455. [[Link](#)]
- Laru, S., et al. (2025). C–H Functionalization of Quinoxalines. *Synlett*, 36, 808–816. [[Link](#)]
- Behera, A., et al. (2021). Recent advances in the transition-metal-free synthesis of quinoxalines. *RSC Advances*, 11(43), 26786-26809. [[Link](#)]
- Mondal, K., Ghosh, S., & Hajra, A. (2022). Transition-Metal-Catalyzed Ortho C–H Functionalization of 2-Arylquinoxalines. *Organic & Biomolecular Chemistry*, 20(37), 7361-7376. [[Link](#)]
- Biscoe, M. R., et al. (2015). Generating Active “L-Pd(0)” via Neutral or Cationic π -Allylpalladium Complexes Featuring Biaryl/Bipyrazolylphosphines. *The Journal of Organic Chemistry*, 50(12), 3450–3458. [[Link](#)]

Chemistry, 80(12), 6425-6444. [[Link](#)]

- Organic Chemistry Portal. (n.d.). Buchwald-Hartwig Cross Coupling Reaction. Organic Chemistry Portal. [[Link](#)]
- Al-Tel, T. H., et al. (2014). Efficient synthesis of 2-phenyl-3-substituted furo/thieno[2,3-b]quinoxalines via Sonogashira coupling reaction followed by iodocyclization and subsequent palladium-catalyzed cross-coupling reactions. RSC Advances, 4(108), 63059-63067. [[Link](#)]
- Abdel-Rahman, A. A.-H. (2003). Synthesis of certain substituted quinoxalines as antimicrobial agents (Part II). Archives of Pharmacal Research, 26(2), 107-13. [[Link](#)]
- Siyo, B. (2012). Regioselective Suzuki Miyaura cross coupling reactions of 2,6-dichloroquinoxaline. ResearchGate. [[Link](#)]
- Organic Chemistry Portal. (n.d.). Quinoxaline synthesis. Organic Chemistry Portal. [[Link](#)]
- Chemistry LibreTexts. (2023). Buchwald-Hartwig Amination. Chemistry LibreTexts. [[Link](#)]
- Kumar, A., & Singh, R. (2011). GREEN SYNTHESIS OF QUINOXALINE AND SUBSTITUTED QUINOXALINES. TSI Journals. [[Link](#)]
- Wikipedia contributors. (2024). Sonogashira coupling. Wikipedia, The Free Encyclopedia. [[Link](#)]
- Organic Chemistry Portal. (n.d.). Sonogashira Coupling. Organic Chemistry Portal. [[Link](#)]
- Ruiz-Castillo, P., & Buchwald, S. L. (2019). The Buchwald–Hartwig Amination After 25 Years. Angewandte Chemie International Edition, 58(48), 17118-17129. [[Link](#)]
- Siyo, B., et al. (2012). Regioselective Suzuki-Miyaura Cross-Coupling Reactions of 2,6-Dichloroquinoxaline. ResearchGate. [[Link](#)]
- Tobisu, M., & Chatani, N. (2016). Nickel-Catalyzed Cross-Coupling Reactions of Unreactive Phenolic Electrophiles via C-O Bond Activation. Accounts of Chemical Research, 49(9), 1735-1745. [[Link](#)]

- Various Authors. (2025). Photo-/electrocatalytic functionalization of quinoxalin-2(1H)-ones. ResearchGate. [\[Link\]](#)
- Gabbai, F. P., et al. (2017). Suzuki coupling catalyzed by chloro({2-[mesityl(quinolin-8-yl-κN)boryl]-3,5-dimethylphenyl}methyl-κC)palladium(II). ResearchGate. [\[Link\]](#)
- Khanye, S. D., et al. (2012). Nucleophilic Substitution on 2-Monosubstituted Quinoxalines Giving 2,3-Disubstituted Quinoxalines: Investigating the Effect of the 2-Substituent. *Molecules*, 17(10), 11866-11881. [\[Link\]](#)
- Mondal, K., Ghosh, S., & Hajra, A. (2022). Transition-metal-catalyzed ortho C-H functionalization of 2-arylquinoxalines. *Organic & Biomolecular Chemistry*, 20(37), 7361-7376. [\[Link\]](#)
- Yakaiah, C., et al. (2016). Synthesis and Photophysical Characterization of Several 2,3-Quinoxaline Derivatives. An Application of Pd(0)/PEG Nanoparticle Catalyst for Sonogashira Coupling. ResearchGate. [\[Link\]](#)
- Jana, A., et al. (2021). Direct functionalization of quinoxalin-2(1H)-one with alkanes: C(sp²)-H/C(sp³)-H cross coupling in transition metal-free mode. *Organic & Biomolecular Chemistry*, 19(36), 7855-7860. [\[Link\]](#)
- Li, J.-H., et al. (2006). Modified Palladium-Catalyzed Sonogashira Cross-Coupling Reactions under Copper-, Amine-, and Solvent-Free Conditions. *The Journal of Organic Chemistry*, 71(1), 379-381. [\[Link\]](#)
- Wang, Y., et al. (2021). Visible light-induced direct and highly selective C-H functionalization of quinoxalin-2(1H)-one without orientating group. *Catalysis Science & Technology*, 11(1), 107-112. [\[Link\]](#)
- Powers, D. C., & Ritter, T. (2011). Cross-Coupling and Related Reactions: Connecting Past Success to the Development of New Reactions for the Future. ResearchGate. [\[Link\]](#)
- Powers, D. C., & Ritter, T. (2011). Cross-Coupling and Related Reactions: Connecting Past Success to the Development of New Reactions for the Future. *Organic Process Research & Development*, 15(4), 743-750. [\[Link\]](#)

- Oshima, K., et al. (2007). Nickel-Catalyzed Selective Cross-Coupling of Chlorosilanes with Organoaluminum Reagents. *Angewandte Chemie International Edition*, 46(27), 5162-5164. [\[Link\]](#)
- Gianatassio, R., et al. (2025). Development of intra- and intermolecular nickel-catalyzed cross-electrophile coupling cascade reactions for the synthesis of carbocycles. *American Chemical Society*. [\[Link\]](#)

Need Custom Synthesis?

BenchChem offers custom synthesis for rare earth carbides and specific isotopic labeling.

Email: info@benchchem.com or [Request Quote Online](#).

Sources

- [1. pdf.benchchem.com](https://pdf.benchchem.com) [pdf.benchchem.com]
- [2. pdf.benchchem.com](https://pdf.benchchem.com) [pdf.benchchem.com]
- [3. asset.library.wisc.edu](https://asset.library.wisc.edu) [asset.library.wisc.edu]
- [4. Nickel-Catalyzed Cross-Coupling Reactions of Unreactive Phenolic Electrophiles via C-O Bond Activation - PubMed](https://pubmed.ncbi.nlm.nih.gov) [pubmed.ncbi.nlm.nih.gov]
- To cite this document: BenchChem. [Technical Support Center: Catalyst Selection for Functionalizing 2-(Chloromethyl)quinoxaline]. BenchChem, [2026]. [Online PDF]. Available at: [<https://www.benchchem.com/product/b019384/docs#technical-support-center-catalyst-selection-for-functionalizing-2-chloromethyl-quinoxaline>]

Disclaimer & Data Validity:

The information provided in this document is for Research Use Only (RUO) and is strictly not intended for diagnostic or therapeutic procedures. While BenchChem strives to provide accurate protocols, we make no warranties, express or implied, regarding the fitness of this product for every specific experimental setup.

Technical Support: The protocols provided are for reference purposes. Unsure if this reagent suits your experiment?

Need Industrial/Bulk Grade? [Request Custom Synthesis Quote](#)

BenchChem

Our mission is to be the trusted global source of essential and advanced chemicals, empowering scientists and researchers to drive progress in science and industry.

Contact

Address: 3281 E Guasti Rd
Ontario, CA 91761, United States
Phone: (601) 213-4426
Email: info@benchchem.com

[Contact our Ph.D. Support Team for a compatibility check](#)