

# Addressing interference in 4-Hydroxy Triamterene Sulfate assays

**Author:** BenchChem Technical Support Team. **Date:** May 2026

## Compound of Interest

**Compound Name:** 4-Hydroxy Triamterene Sulfate,  
Sodium Salt

**CAS No.:** 73756-87-3

**Cat. No.:** B019465

[Get Quote](#)

## Technical Support Center: Triamterene & Metabolite Assays

### Topic: Addressing Interference in 4-Hydroxy Triamterene Sulfate Assays

Status: Operational | Lead Scientist: Dr. A. Vance | Ticket Priority: High

## Welcome to the Bioanalytical Support Hub

You are likely here because your pharmacokinetic data for Triamterene (TA) isn't adding up. Specifically, you are seeing inconsistent quantification of its primary Phase II metabolite, 4-Hydroxytriamterene Sulfate (4-OH-TA-S), or you suspect this conjugate is interfering with the measurement of the Phase I metabolite, 4-Hydroxytriamterene (4-OH-TA).

In my 15 years developing pteridine assays, I have found that 4-OH-TA-S is deceptive. It is highly abundant in urine (often 10x the parent drug), labile in the MS source, and naturally

fluorescent. This guide addresses the three most common "interference" tickets we receive: In-Source Fragmentation (ISF), Matrix Suppression, and Stability Issues.

## Module 1: The "Phantom" Peak (In-Source Fragmentation)

User Question: "I am detecting 4-OH-TA (the Phase I metabolite) in samples where I only spiked the Sulfate conjugate. Is my standard contaminated?"

Technical Diagnosis: It is highly unlikely your standard is contaminated. You are experiencing In-Source Fragmentation (ISF).<sup>[1]</sup> In Positive Electrospray Ionization (+ESI), sulfate conjugates are thermally and energetically labile. Before the ions even reach the collision cell (Q2), the heated source can cleave the sulfate group (

).

- The Chemistry: 4-OH-TA-S (350) loses 80 Da ( ) becomes 4-OH-TA (270).
- The Consequence: If 4-OH-TA-S and 4-OH-TA co-elute chromatographically, the mass spectrometer cannot distinguish between the "real" 4-OH-TA and the "artifact" created from the sulfate. This leads to massive overestimation of the Phase I metabolite.

## The Solution: Orthogonal Chromatographic Separation

You cannot stop ISF entirely in the source. You must separate the two compounds in time.

Actionable Protocol:

- Check Resolution ( ): Ensure baseline separation (

) between the Sulfate and the Phase I metabolite.

- Monitor the "Crosstalk": Inject a pure standard of 4-OH-TA-S (e.g., 1000 ng/mL). Monitor the transition for 4-OH-TA ( ).
  - Result: You will see a peak in the 270 channel at the retention time of the Sulfate. This is your "ISF artifact."
  - Pass Criteria: This artifact peak must not overlap with the retention time of the actual 4-OH-TA.

## Visualizing the Interference Mechanism

The following diagram illustrates how ISF creates false data if chromatography is poor.

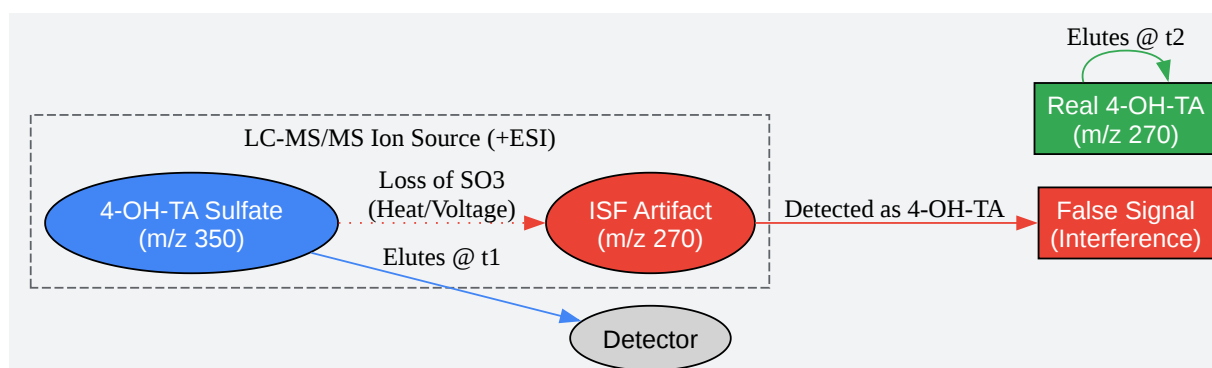

[Click to download full resolution via product page](#)

Figure 1: Mechanism of In-Source Fragmentation (ISF). If the Sulfate (blue) converts to the artifact (red) and co-elutes with the real metabolite (green), quantification fails.

## Module 2: Matrix Effects & Extraction

User Question: "My internal standard (IS) recovery in urine samples is erratic, and the sulfate peak shape is tailing. How do I clean this up?"

Technical Diagnosis: Urine contains high concentrations of salts and endogenous pigments that suppress ionization. Furthermore, Triamterene and its metabolites are pteridines—they are heterocyclic bases that can interact strongly with residual silanols on HPLC columns, causing tailing.

## The Solution: Dilution & pH Control

For urine, "Dilute-and-Shoot" is often superior to Solid Phase Extraction (SPE) because the sulfate concentration is naturally very high (often

).

Optimized Workflow:

Parameter	Recommendation	Rationale
Internal Standard	Triamterene-d5 or 13C-4-OH-TA	Structural analogs (like furosemide) do not track the specific ionization suppression of pteridines.
Sample Prep (Urine)	Dilute 1:10 or 1:20 with Mobile Phase A.	Reduces matrix effect; prevents column saturation.
Sample Prep (Plasma)	Protein Precipitation (PPT) with acidified Methanol.	Acid ensures the basic pteridines remain in solution and don't bind to precipitated proteins.
Mobile Phase pH	Acidic (pH 3.0 - 4.0)	Suppresses silanol ionization on the column, sharpening the peak shape of the basic pteridine ring.

## Experimental Workflow: Sample Preparation Decision Tree

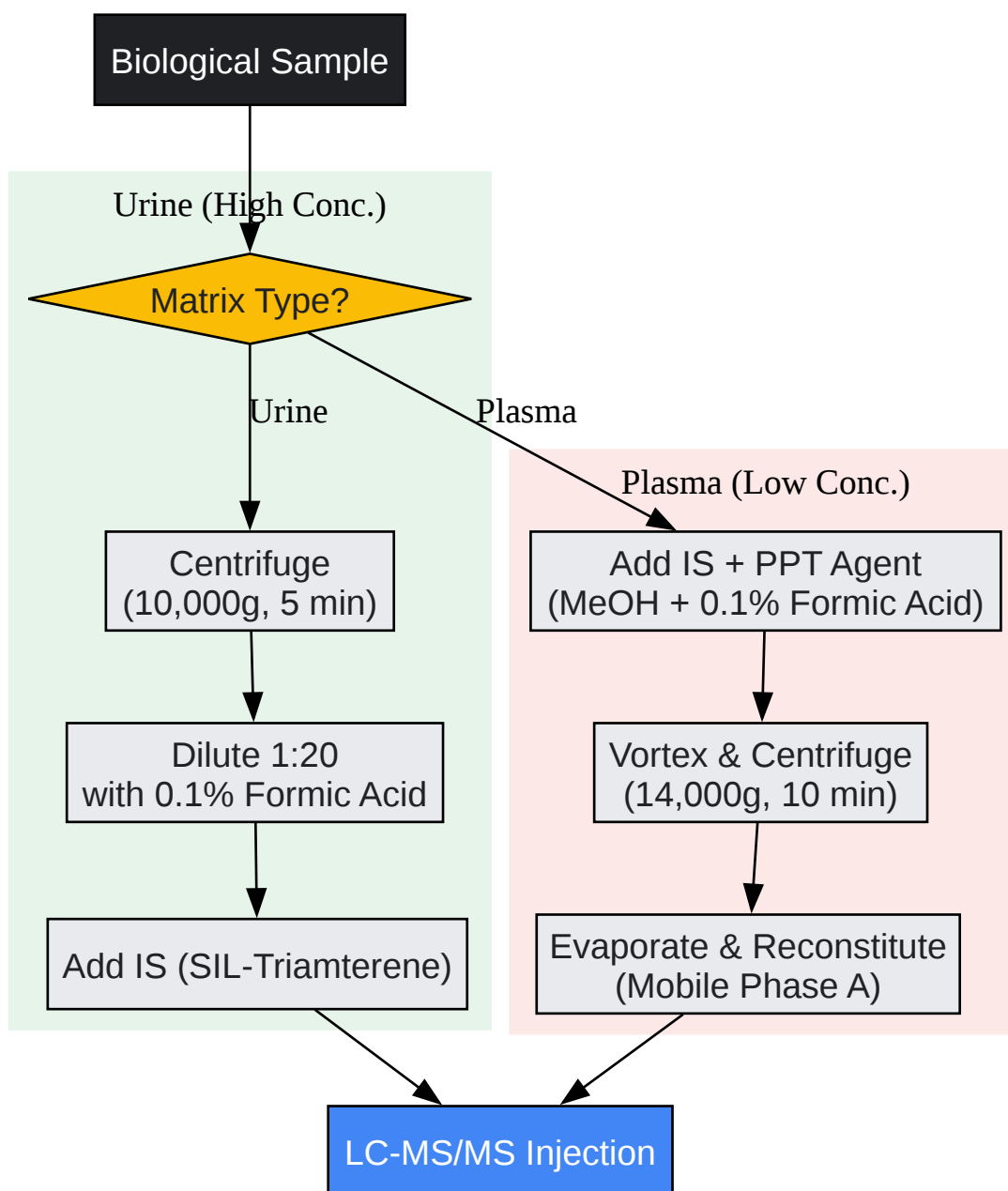

[Click to download full resolution via product page](#)

Figure 2: Decision tree for sample preparation to minimize matrix interference.

## Module 3: Stability & Handling FAQs

Q: Can I store processed samples in the autosampler overnight? A: Yes, but temperature control is mandatory. 4-OH-TA-S is relatively stable, but we observe degradation if the autosampler is not kept at 4°C. In urine, bacterial contamination can introduce sulfatases which hydrolyze the sulfate back to 4-OH-TA, ruining the assay.

- Fix: Add 0.1% Sodium Azide to urine collection containers if storage >24h is expected, or freeze immediately at -80°C.

Q: I'm seeing "Carryover" in the blank after a high concentration sample. A: Triamterene is "sticky" due to its flat, aromatic pteridine structure.

- Fix: Use a needle wash with high organic strength and low pH (e.g., 50:50 Acetonitrile:Isopropanol + 0.5% Formic Acid). The acid helps protonate the amine groups, increasing solubility in the wash solvent.

## References

- Gundert-Remy, U., et al. (1979). "Plasma and urinary levels of triamterene and certain metabolites after oral administration to man." [2][3][4][5][6] *European Journal of Clinical Pharmacology*.
- Gilfrich, H.J., et al. (1983). [7] "Pharmacokinetics of triamterene and its active metabolite in patients with renal failure." *European Journal of Clinical Pharmacology*.
- Xu, X., et al. (2023). "Widespread occurrence of in-source fragmentation in the analysis of natural compounds by liquid chromatography-electrospray ionization mass spectrometry." *Rapid Communications in Mass Spectrometry*.
- Clinical and Laboratory Standards Institute (CLSI). (2005). "Interference Testing in Clinical Chemistry; Approved Guideline—Second Edition." CLSI document EP7-A2.

For further assistance, please upload your chromatograms (specifically the MRM transitions for 350>fragments and 270>fragments) to the secure portal.

### *Need Custom Synthesis?*

*BenchChem offers custom synthesis for rare earth carbides and specific isotopic labeling.*

*Email: [info@benchchem.com](mailto:info@benchchem.com) or [Request Quote Online](#).*

## Sources

- 1. Widespread occurrence of in-source fragmentation in the analysis of natural compounds by liquid chromatography-electrospray ionization mass spectrometry - PubMed [[pubmed.ncbi.nlm.nih.gov](https://pubmed.ncbi.nlm.nih.gov)]
- 2. [drugs.com](https://www.drugs.com) [[drugs.com](https://www.drugs.com)]
- 3. Plasma and urinary levels of triamterene and certain metabolites after oral administration to man - PubMed [[pubmed.ncbi.nlm.nih.gov](https://pubmed.ncbi.nlm.nih.gov)]
- 4. [researchgate.net](https://www.researchgate.net) [[researchgate.net](https://www.researchgate.net)]
- 5. Triamterene: Uses, Side Effects & Dosage | Healio [[healio.com](https://www.healio.com)]
- 6. [scielo.br](https://scielo.br) [[scielo.br](https://scielo.br)]
- 7. Mechanistic and Other Relevant Data - Some Drugs and Herbal Products - NCBI Bookshelf [[ncbi.nlm.nih.gov](https://pubmed.ncbi.nlm.nih.gov)]
- To cite this document: BenchChem. [Addressing interference in 4-Hydroxy Triamterene Sulfate assays]. BenchChem, [2026]. [Online PDF]. Available at: [<https://www.benchchem.com/product/b019465/docs#addressing-interference-in-4-hydroxy-triamterene-sulfate-assays>]

---

#### Disclaimer & Data Validity:

The information provided in this document is for Research Use Only (RUO) and is strictly not intended for diagnostic or therapeutic procedures. While BenchChem strives to provide accurate protocols, we make no warranties, express or implied, regarding the fitness of this product for every specific experimental setup.

**Technical Support:** The protocols provided are for reference purposes. Unsure if this reagent suits your experiment?

**Need Industrial/Bulk Grade?** [Request Custom Synthesis Quote](#)

# BenchChem

Our mission is to be the trusted global source of essential and advanced chemicals, empowering scientists and researchers to drive progress in science and industry.

## Contact

Address: 3281 E Guasti Rd

Ontario, CA 91761, United States

Phone: (601) 213-4426

Email: [info@benchchem.com](mailto:info@benchchem.com)

[Contact our Ph.D. Support Team for a compatibility check](#)