

Application Note: Chemoselective Nitration of 2,2-Dimethyl-1,3-benzodioxole

Author: BenchChem Technical Support Team. **Date:** May 2026

Compound of Interest

Compound Name: *2,2-Dimethyl-5-nitro-1,3-benzodioxole*

CAS No.: 54186-68-4

Cat. No.: B189132

[Get Quote](#)

Abstract

This guide details the experimental protocol for the regioselective mononitration of 2,2-dimethyl-1,3-benzodioxole (acetone catechol ketal) to synthesize **2,2-dimethyl-5-nitro-1,3-benzodioxole** (CAS: 54186-68-4).^{[1][2][3][4]} Unlike stable methylenedioxy analogs, the 2,2-dimethyl ketal functionality is acid-labile and prone to hydrolysis under aqueous acidic conditions.^{[3][4]} This protocol utilizes a mild, non-aqueous nitration system (HNO₃ in glacial acetic acid) to preserve the heterocycle while achieving high regioselectivity for the 5-position.^[3]

Strategic Analysis & Chemical Logic

Substrate Sensitivity & Selection of Nitrating Agent

The core challenge in nitrating 2,2-dimethyl-1,3-benzodioxole is the stability of the dioxole ring.^{[3][4]}

- **Acid Sensitivity:** The gem-dimethyl group introduces steric strain and stabilizes the carbocation intermediate formed during ring opening.[3][4] Consequently, this ketal hydrolyzes approx. times faster than the unsubstituted methylenedioxy acetal in aqueous acid.[3]
- **Exclusion of Mixed Acids:** Standard nitration conditions using sulfuric acid (mixed acid) generate water and heat, which will rapidly hydrolyze the substrate to 4-nitrocatechol and acetone.[3]
- **Solution:** The use of Nitric Acid in Glacial Acetic Acid provides an anhydrous medium that buffers the acidity, preventing ketal hydrolysis while maintaining sufficient electrophilicity for the activated aromatic ring.[3]

Regioselectivity Mechanism

The 1,3-benzodioxole ring is strongly activating and ortho/para directing.[3]

- **Positions 4/7 (Ortho):** Sterically hindered by the gem-dimethyl group and the adjacent oxygen lone pairs (Mills-Nixon effect).[3][4]
- **Positions 5/6 (Para):** Electronically favored and sterically accessible.[3]
- **Outcome:** The reaction yields almost exclusively the 5-nitro isomer.[3]

Experimental Protocol

Materials & Equipment

Component	Specification	Quantity (Scale)	Molar Eq.
Substrate	2,2-Dimethyl-1,3-benzodioxole	15.0 g	1.0 eq (100 mmol)
Reagent A	Nitric Acid (65-70%, d=1.3)[4]	10.0 mL	~1.5 eq
Solvent	Glacial Acetic Acid (Anhydrous)	100 mL total	N/A
Quench	Crushed Ice / DI Water	500 g	N/A
Purification	Ethanol or Methanol	~50 mL	N/A

Equipment:

- 250 mL 3-neck Round Bottom Flask (RBF)[3][4]
- Pressure-equalizing addition funnel[3][4]
- Thermometer (internal probe)[3][4]
- Magnetic stir plate & bar[3]
- Ice/Water bath[3][4]

Step-by-Step Procedure

Phase 1: Preparation of Nitrating Mixture[3]

- Charge: In a separate beaker, measure 30 mL of Glacial Acetic Acid.
- Addition: Carefully add 10.0 mL of Nitric Acid to the acetic acid.
- Cooling: Swirl to mix and cool to room temperature (exothermic mixing). Caution: Do not add acetic acid to nitric acid; always add nitric acid to the solvent.[3]

Phase 2: Reaction Setup

- **Substrate Dissolution:** In the 250 mL 3-neck RBF, dissolve 15.0 g of 2,2-Dimethyl-1,3-benzodioxole in 70 mL of Glacial Acetic Acid.
- **Temperature Control:** Place the flask in an ice/water bath. Cool the internal temperature to 10–15 °C.

Phase 3: Nitration (The Critical Step)[3]

- **Controlled Addition:** Transfer the Nitric/Acetic acid mixture to the addition funnel.
- **Rate:** Add the acid mixture dropwise over 30–45 minutes.
 - **Critical Parameter:** Maintain internal temperature between 15 °C and 25 °C. Do not exceed 25 °C to prevent dinitration or oxidative ring opening.[3]
- **Digestion:** Once addition is complete, remove the ice bath. Allow the mixture to stir at room temperature (20–25 °C) for 2–4 hours.
 - **Monitoring:** TLC (Solvent: 20% EtOAc/Hexanes) should show consumption of starting material ($R_f \sim 0.8$) and appearance of the product ($R_f \sim 0.5$).[3]

Phase 4: Workup & Isolation

- **Quenching:** Pour the reaction mixture slowly onto 500 g of crushed ice with vigorous stirring. The product will precipitate as a yellow solid.[3]
- **Filtration:** Stir for 30 minutes to ensure full precipitation. Filter the solid using a Büchner funnel.[3]
- **Washing:** Wash the filter cake copiously with cold water (3 x 100 mL) until the filtrate is neutral (pH ~ 7). This removes residual acetic/nitric acid which could degrade the product during drying.[3]

Phase 5: Purification

- **Recrystallization:** Transfer the crude yellow solid to a flask.
- **Solvent:** Recrystallize from hot Ethanol (or Methanol). Dissolve at reflux, filter hot if necessary, and cool slowly to 4 °C.

- Drying: Dry the yellow needles in a vacuum desiccator over
or Silica Gel.[3]

Results & Characterization

Parameter	Value / Observation
Appearance	Yellow crystalline needles
Yield	75% – 85% (Expected: ~15-16 g)
Melting Point	87 – 93 °C [Ref 1, 2]
Regioselectivity	>95% 5-nitro isomer
Stability	Stable at RT; store away from strong acids.[3][4]

Spectroscopic Data (Typical):

- ¹H NMR (CDCl₃, 400 MHz):
1.72 (s, 6H, 2xCH₃), 6.82 (d, J=8.5 Hz, 1H, H-7), 7.65 (d, J=2.2 Hz, 1H, H-4), 7.88 (dd, J=8.5, 2.2 Hz, 1H, H-6).[3][4]
- Key Feature: The singlet at 1.72 ppm confirms the integrity of the gem-dimethyl ketal ring.[3]

Process Visualization

Reaction Workflow Diagram

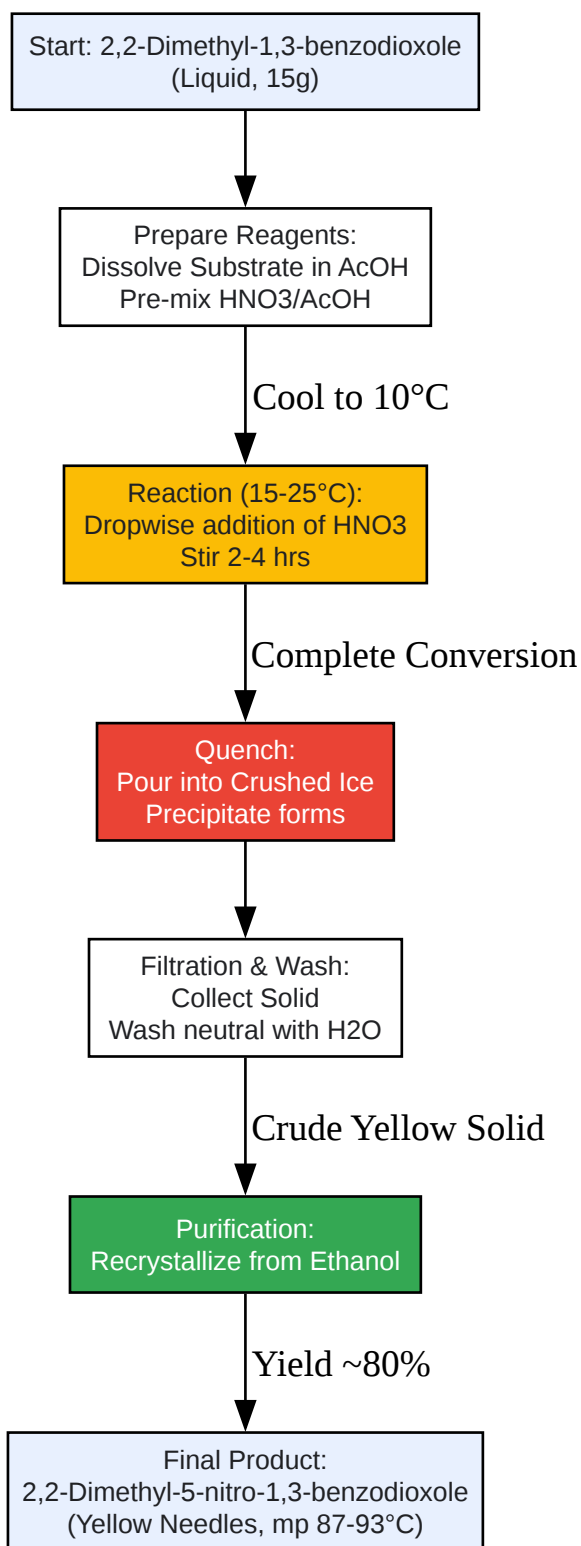

[Click to download full resolution via product page](#)

Caption: Step-by-step workflow for the chemoselective nitration process.

Mechanism & Regioselectivity

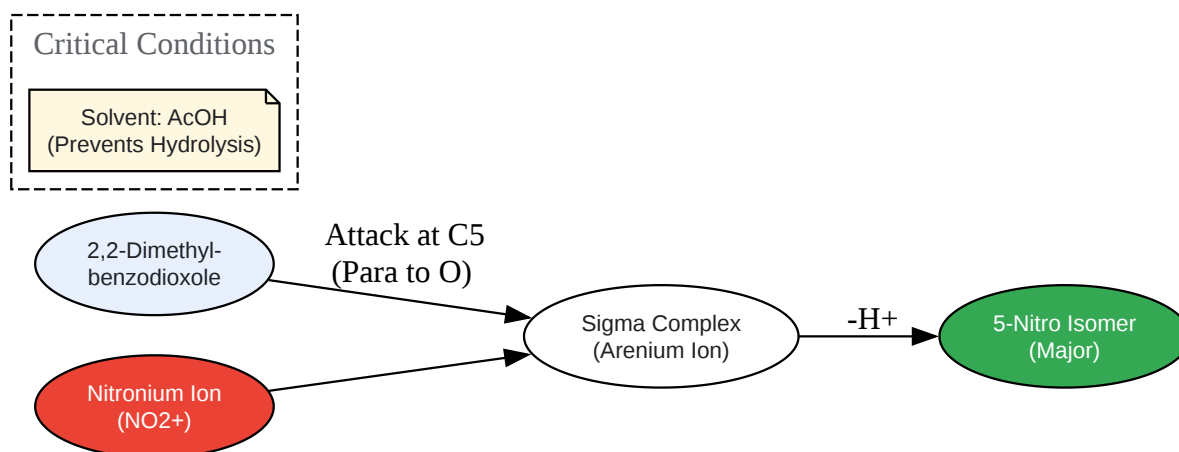

[Click to download full resolution via product page](#)

Caption: Electrophilic Aromatic Substitution pathway highlighting C5 regioselectivity.

Troubleshooting & Expert Tips

- Problem: Oily Product.
 - Cause: Incomplete precipitation or presence of acetic acid.[3]
 - Fix: Scratch the flask walls with a glass rod to induce crystallization while on ice.[3] Ensure the water wash is thorough.[3]
- Problem: Low Yield / Ring Opening.
 - Cause: Temperature exceeded 25 °C or water was present in the reaction mix.[3]
 - Fix: Ensure all glassware is dry.[3] Use Glacial Acetic Acid.[3] Keep the addition rate slow to manage the exotherm.[3]
- Safety Note: Nitration reactions are exothermic and can run away.[3] Never add the organic substrate directly to neat nitric acid.[3] Always dilute the nitrating agent or add it to the substrate solution.[3]

References

- Sigma-Aldrich. Product Specification: **2,2-dimethyl-5-nitro-1,3-benzodioxole** (CAS 54186-68-4). [1][2][3][4] Retrieved from [3][4]
- ChemicalBook. **2,2-Dimethyl-5-nitro-1,3-benzodioxole** Properties & Suppliers. Retrieved from [3][4]
- PrepChem. Synthesis of 5-nitro-1,3-benzodioxole (Analogous Procedure). Retrieved from [3][4]
- PubChem. Compound Summary: **2,2-dimethyl-5-nitro-1,3-benzodioxole**. [1][2][3][4] Retrieved from [3][4]

Need Custom Synthesis?

BenchChem offers custom synthesis for rare earth carbides and specific isotopic labeling.

Email: info@benchchem.com or [Request Quote Online](#).

Sources

- 1. 1461713-64-3,2-(aminomethyl)-1,3-thiazole-4-carboxylic acid dihydrochloride-AccelaChem|AccelaChemBio|Accela design, synthesis, manufacture and market advanced R&D chemicals; 韶远科技 (上海) 有限公司 [accelachem.com]
- 2. 1461706-23-9,1-(1,2,3,4-tetrahydronaphthalen-1-ylmethyl)pyrrolidine-3-carboxylic acid hydrochloride-AccelaChem|AccelaChemBio|Accela design, synthesis, manufacture and market advanced R&D chemicals; 韶远科技 (上海) 有限公司 [accelachem.com]
- 3. prepchem.com [prepchem.com]
- 4. 2,2-Dimethyl-1,3-benzodioxole | 14005-14-2 [chemicalbook.com]
- To cite this document: BenchChem. [Application Note: Chemoselective Nitration of 2,2-Dimethyl-1,3-benzodioxole]. BenchChem, [2026]. [Online PDF]. Available at: [https://www.benchchem.com/product/b189132/docs#application-note-chemoselective-nitration-of-2-2-dimethyl-1-3-benzodioxole]

Disclaimer & Data Validity:

The information provided in this document is for Research Use Only (RUO) and is strictly not intended for diagnostic or therapeutic procedures. While BenchChem strives to provide accurate protocols, we make no warranties, express or implied, regarding the fitness of this product for every specific experimental setup.

Technical Support: The protocols provided are for reference purposes. Unsure if this reagent suits your experiment?

Need Industrial/Bulk Grade? [Request Custom Synthesis Quote](#)

BenchChem

Our mission is to be the trusted global source of essential and advanced chemicals, empowering scientists and researchers to drive progress in science and industry.

Contact

Address: 3281 E Guasti Rd
Ontario, CA 91761, United States
Phone: (601) 213-4426
Email: info@benchchem.com

[Contact our Ph.D. Support Team for a compatibility check](#)