

A Senior Application Scientist's Guide to Benchmarking Thiazole Synthesis Methodologies

Author: BenchChem Technical Support Team. **Date:** May 2026

Compound of Interest

Compound Name: Ethyl 2-(2,4-dimethylthiazol-5-yl)acetate
CAS No.: 405921-41-7
Cat. No.: B188267

[Get Quote](#)

For researchers, scientists, and professionals in drug development, the synthesis of the thiazole ring is a foundational technique in medicinal chemistry. This five-membered heterocycle is a privileged scaffold, forming the core of numerous FDA-approved drugs due to its broad spectrum of biological activities.[1] The choice of synthetic route to a desired thiazole derivative is a critical decision, often involving a trade-off between reaction efficiency, substrate scope, scalability, and environmental impact.

This guide provides an in-depth comparative analysis of prominent thiazole synthesis methodologies. We will delve into the classic Hantzsch, Cook-Heilbron, and Gabriel syntheses, and explore modern advancements, including microwave-assisted and continuous flow techniques. By presenting objective, side-by-side comparisons supported by experimental data, this guide aims to empower you to select the optimal synthetic strategy for your specific research needs.

Comparative Analysis of Key Thiazole Synthesis Methodologies

The selection of a synthetic pathway is dictated by the desired substitution pattern on the thiazole ring, the availability and complexity of starting materials, and the desired operational efficiency. Here, we compare the key performance indicators of the most common and innovative methods for thiazole synthesis.

At a Glance: A Quantitative Comparison of Thiazole Synthesis Routes

The following table provides a summary of the key quantitative parameters for the discussed synthetic methodologies, offering a clear comparison of their efficiencies.

Synthesis Route	Key Reactants	Catalyst /Conditions	Typical Reaction Time	Typical Temperature (°C)	Typical Yield (%)	Key Advantages	Disadvantages
Hantzsch Synthesis (Conventional)	α -Haloketone, Thioamide/Thiourea	Methanol, Heat	30 min - 12 h	65 - 100	80 - 99+	High yields, simple procedure, broad substrate scope.[2][3]	Can require long reaction times and high temperatures.[4]
Cook-Heilbron Synthesis	α -Aminonitrile, Carbon Disulfide	Mild/Aqueous	Not specified	Room Temperature	"Significant"	Mild reaction conditions, synthesis of 5-aminothiazoles.[5]	Limited to 5-aminothiazole derivatives.
Gabriel Synthesis	α -Acylamino ketone	Phosphorus Pentasulfide (P ₄ S ₁₀)	Not specified	~170	Not specified	Access to 2,5-disubstituted thiazoles.[4][6]	Harsh conditions (high temperature, strong dehydrating agent).[4]
Microwave-Assisted Hantzsch Synthesis	α -Haloketone, Thiourea	Ethanol, Microwave Irradiation	5 - 30 min	90 - 150	89 - 95+	Dramatically reduced reaction times, high	Requires specialized microwave reactor.

yields,
improved
purity.[7]
[8]

Scalable,
rapid,
efficient,
safe
handling
of
reactive
intermedi
ates.[9]
[10]

Continuous Flow Hantzsch Synthesis	α -Haloketone, Thioamide	High Temperature/Pressure	< 15 min	150 - 200	39 - 91
------------------------------------	---------------------------------	---------------------------	----------	-----------	---------

Visualizing the Synthetic Pathways

To further elucidate the transformations involved in these syntheses, the following diagrams, generated using the DOT language, illustrate the core experimental workflows.

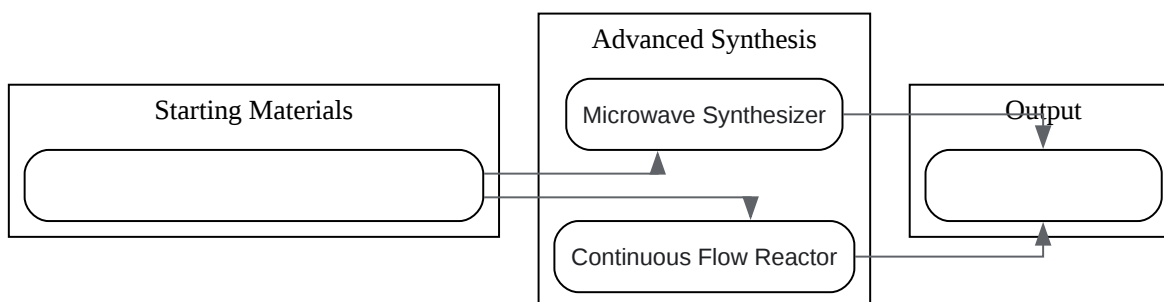
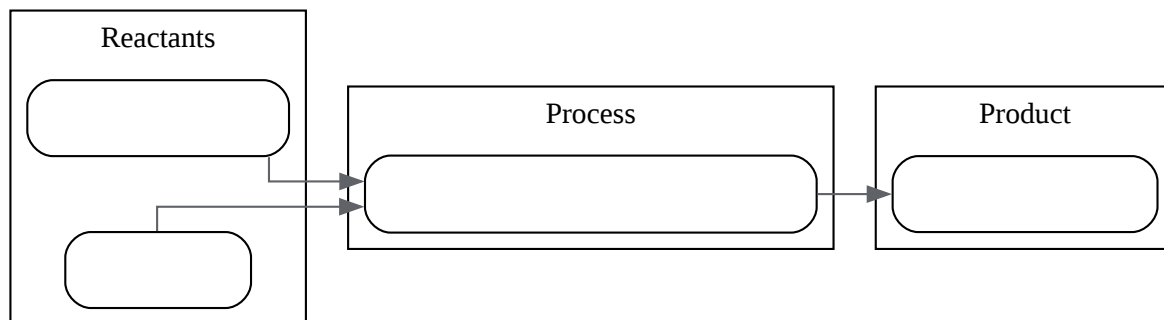

[Click to download full resolution via product page](#)

Caption: High-level workflow for modern thiazole synthesis methods.

In-Depth Experimental Protocols

A cornerstone of reproducible science is the detailed documentation of experimental procedures. This section provides step-by-step protocols for the key thiazole synthesis methodologies discussed.

Conventional Hantzsch Thiazole Synthesis

This protocol describes the synthesis of 2-amino-4-phenylthiazole. [2] Materials:

- 2-Bromoacetophenone (5.0 mmol)
- Thiourea (7.5 mmol)

- Methanol (5 mL)
- 5% Sodium Carbonate (Na_2CO_3) solution (20 mL)
- 20 mL scintillation vial with stir bar
- Hot plate
- Buchner funnel and side-arm flask

Procedure:

- In a 20 mL scintillation vial, combine 2-bromoacetophenone (5.0 mmol) and thiourea (7.5 mmol).
- Add methanol (5 mL) and a stir bar to the vial.
- Heat the mixture with stirring on a hot plate set to 100°C for 30 minutes.
- Remove the reaction from the heat and allow the solution to cool to room temperature.
- Pour the contents of the vial into a 100 mL beaker containing 20 mL of 5% Na_2CO_3 solution and swirl to mix.
- Filter the resulting precipitate through a Buchner funnel.
- Wash the filter cake with water.
- Spread the collected solid on a tared watchglass and allow it to air dry to obtain the 2-amino-4-phenylthiazole product. A yield of approximately 99% can be expected. [\[11\]](#)

Microwave-Assisted Hantzsch Thiazole Synthesis

This protocol details a rapid, one-pot, three-component synthesis of substituted thiazole derivatives under microwave irradiation. [\[8\]](#) Materials:

- Substituted α -bromoketone (1 mmol)
- Substituted thiourea (1.1 mmol)

- Ethanol (3 mL)
- 10 mL microwave reactor vials with stir bars
- Microwave synthesizer

Procedure:

- In a 10 mL microwave reactor vial, combine the substituted α -bromoketone (1 mmol), substituted thiourea (1.1 mmol), and ethanol (3 mL).
- Seal the vial and place it in the microwave synthesizer.
- Irradiate the reaction mixture at a constant power of 170 W for a duration of 5-15 minutes.
- Monitor the reaction progress using Thin Layer Chromatography (TLC).
- After completion, allow the reaction mixture to cool to room temperature.
- Pour the cooled mixture into ice water to precipitate the product.
- Filter the precipitate, wash with cold water, and dry.
- Recrystallize the crude product from ethanol to obtain the pure 2-aminothiazole derivative. Yields are typically high, often exceeding 90%. [8]

Cook-Heilbron Thiazole Synthesis (Representative Protocol)

This representative protocol is for the synthesis of 5-amino-2-mercaptotiazole. [4] Materials:

- α -Aminonitrile (e.g., aminoacetonitrile) (1 equivalent)
- Carbon disulfide (CS₂) (1 equivalent)
- A suitable solvent (e.g., ethanol)

Procedure:

- Dissolve the α -aminonitrile in a suitable solvent in a reaction vessel.
- Add carbon disulfide to the solution at room temperature with stirring.
- Continue stirring the reaction mixture under mild conditions. The reaction progress can be monitored by TLC.
- Upon completion, the 5-amino-2-mercaptothiazole product may precipitate from the reaction mixture or can be isolated by solvent evaporation and subsequent purification.

Gabriel Thiazole Synthesis (Representative Protocol)

This protocol provides a general procedure for the Gabriel synthesis of a 2,5-disubstituted thiazole. [4] Materials:

- α -Acylamino ketone (e.g., N-(2-oxopropyl)acetamide) (1 equivalent)
- Phosphorus pentasulfide (P_4S_{10}) (1 equivalent)
- High-boiling point solvent (optional)

Procedure:

- Combine the α -acylamino ketone and phosphorus pentasulfide in a reaction vessel suitable for high-temperature reactions.
- Heat the mixture to approximately 170°C. [6]3. Maintain the reaction at this temperature until the starting material is consumed (monitor by TLC if possible, though the high temperature may be challenging).
- After cooling, the reaction mixture is typically worked up by careful quenching with water or a basic solution to decompose any remaining P_4S_{10} .
- The 2,5-disubstituted thiazole product is then extracted with an organic solvent and purified by chromatography or recrystallization.

Continuous Flow Hantzsch Thiazole Synthesis

This section describes a general setup for a continuous flow synthesis of β -ketothiazoles. [9]

Equipment:

- Continuous flow microreactor system with pumps and a heated reactor coil.

Procedure:

- Prepare separate stock solutions of the α -bromoacetophenone and the thioamide in a suitable solvent (e.g., methanol with a small equivalent of water).
- Pump the two solutions into a T-mixer to combine them.
- The combined stream is then passed through a heated reactor coil (e.g., at 150°C). The residence time is controlled by the flow rate and the reactor volume, and is typically less than 15 minutes.
- The output from the reactor is collected. The product can be isolated by crystallization or other purification techniques. Electron-rich α -bromoacetophenones have been shown to give excellent isolated yields (90-91%) with this method. [9]

Conclusion

The synthesis of the thiazole core remains a vibrant and essential area of research in medicinal chemistry. While the classical Hantzsch, Cook-Heilbron, and Gabriel syntheses provide foundational and versatile routes to a wide array of thiazole derivatives, modern techniques offer significant advantages in terms of efficiency and sustainability.

Microwave-assisted synthesis has proven to be a powerful tool for accelerating reaction times and improving yields, making it an excellent choice for rapid library synthesis and methods development. [7][8] For larger-scale production and processes where safety and automation are paramount, continuous flow synthesis presents a compelling alternative, offering high throughput and precise control over reaction parameters. [9] Ultimately, the choice of the optimal synthesis method will depend on the specific goals of the research program, including the desired substitution pattern, scale of the reaction, and available laboratory equipment. This guide provides the foundational data and protocols to make an informed decision, empowering researchers to efficiently access the valuable thiazole scaffold for their drug discovery and development endeavors.

References

Need Custom Synthesis?

BenchChem offers custom synthesis for rare earth carbides and specific isotopic labeling.

Email: info@benchchem.com or [Request Quote Online](#).

Sources

- [1. researchgate.net \[researchgate.net\]](#)
- [2. One-Pot Chemoenzymatic Multicomponent Synthesis of Thiazole Derivatives \[mdpi.com\]](#)
- [3. Synthesis and Biological Evaluation of New Substituted Hantzsch Thiazole Derivatives from Environmentally Benign One-Pot Synthesis Using Silica Supported Tungstosilicic Acid as Reusable Catalyst - PMC \[pmc.ncbi.nlm.nih.gov\]](#)
- [4. One moment, please... \[mjas.analis.com.my\]](#)
- [5. Cook–Heilbron thiazole synthesis - Wikipedia \[en.wikipedia.org\]](#)
- [6. An Overview of the Synthesis and Antimicrobial, Antiprotozoal, and Antitumor Activity of Thiazole and Bisthiazole Derivatives - PMC \[pmc.ncbi.nlm.nih.gov\]](#)
- [7. Microwave-assisted Hantzsch thiazole synthesis of N-phenyl-4-\(6-phenylimidazo\[2,1-b\]thiazol-5-yl\)thiazol-2-amines from the reaction of 2-chloro-1-\(6-phenylimidazo\[2,1-b\]thiazol-5-yl\)ethanones and thioureas - PMC \[pmc.ncbi.nlm.nih.gov\]](#)
- [8. pdf.benchchem.com \[pdf.benchchem.com\]](#)
- [9. akjournals.com \[akjournals.com\]](#)
- [10. Automated Multistep Continuous Flow Synthesis of 2-\(1H-Indol-3-yl\)thiazole Derivatives. | Semantic Scholar \[semanticscholar.org\]](#)
- [11. researchgate.net \[researchgate.net\]](#)
- To cite this document: BenchChem. [A Senior Application Scientist's Guide to Benchmarking Thiazole Synthesis Methodologies]. BenchChem, [2026]. [Online PDF]. Available at: [\[https://www.benchchem.com/product/b188267/docs#a-senior-application-scientist-s-guide-to-benchmarking-thiazole-synthesis-methodologies\]](https://www.benchchem.com/product/b188267/docs#a-senior-application-scientist-s-guide-to-benchmarking-thiazole-synthesis-methodologies)

Disclaimer & Data Validity:

The information provided in this document is for Research Use Only (RUO) and is strictly not intended for diagnostic or therapeutic procedures. While BenchChem strives to provide accurate protocols, we make no warranties, express or implied, regarding the fitness of this product for every specific experimental setup.

Technical Support: The protocols provided are for reference purposes. Unsure if this reagent suits your experiment?

Need Industrial/Bulk Grade? [Request Custom Synthesis Quote](#)

BenchChem

Our mission is to be the trusted global source of essential and advanced chemicals, empowering scientists and researchers to drive progress in science and industry.

Contact

Address: 3281 E Guasti Rd
Ontario, CA 91761, United States
Phone: (601) 213-4426
Email: info@benchchem.com

[Contact our Ph.D. Support Team for a compatibility check](#)