

Technical Support Center: Spirocyclic Compound NMR Interpretation

Author: BenchChem Technical Support Team. **Date:** May 2026

Compound of Interest

Compound Name:	7,9-Dioxo-8-azaspiro[4.5]decane-6,10-dicarbonitrile
CAS No.:	42940-56-7
Cat. No.:	B185648

[Get Quote](#)

Welcome to the technical support center for the NMR analysis of spirocyclic compounds. This guide is designed for researchers, medicinal chemists, and drug development professionals who encounter the unique challenges posed by the rigid, three-dimensional structures of spirocycles. Here, we address specific issues in a practical, question-and-answer format, blending foundational theory with field-proven insights to empower you to solve complex spectral puzzles.

Troubleshooting Guide: In-Depth Problem Solving

This section tackles common, complex scenarios encountered during the structural elucidation of spirocyclic molecules.

Q1: My ^1H NMR spectrum is a forest of overlapping signals. How can I begin to assign protons in a rigid spirocyclic system?

A1: The Challenge of Signal Crowding and the Power of 2D NMR

The conformational rigidity of spirocyclic systems often leads to severe signal overlap in 1D ^1H NMR spectra.[1][2] This is because the fixed spatial arrangement prevents the averaging of magnetic environments that occurs in more flexible molecules, resulting in many distinct, often overlapping multiplets.[3] Attempting to assign a structure from this "forest" of signals using only a 1D spectrum is inefficient and prone to error.

The solution is to move from a one-dimensional to a two-dimensional analysis. 2D NMR experiments spread the information across two frequency axes, dramatically improving resolution and revealing connectivity networks that are hidden in the 1D spectrum.[4][5]

Your Core Experimental Workflow:

- COSY (Correlation Spectroscopy): This is your starting point. COSY reveals proton-proton couplings through two or three bonds (^2JHH , ^3JHH).[6] This allows you to trace out individual spin systems within the molecule, essentially building a map of which protons are neighbors in the covalent framework. For a spirocycle, this will help you define the proton networks within each ring.
- TOCSY (Total Correlation Spectroscopy): If COSY provides fragmented spin systems (e.g., broken by a heteroatom or quaternary carbon), TOCSY is the next step. It extends the correlation beyond direct neighbors to all protons within a coupled network. This is invaluable for identifying all protons belonging to a specific ring system, even if they are not directly coupled.
- HSQC (Heteronuclear Single Quantum Coherence): This experiment correlates each proton signal directly to the carbon it is attached to (^1JCH).[7] It is the most reliable way to assign protonated carbons. By overlaying your COSY and TOCSY pathways on the HSQC spectrum, you can simultaneously assign both the ^1H and ^{13}C signals for all CH and CH_2 groups.
- HMBC (Heteronuclear Multiple Bond Correlation): This is the key to connecting the fragments. HMBC shows correlations between protons and carbons over two to three bonds (^2JCH , ^3JCH), and sometimes even four bonds.[7][8] It is crucial for identifying quaternary carbons (including the spirocenter) and for linking the different spin systems you identified with COSY and TOCSY. For instance, a proton on one ring showing an HMBC correlation to a carbon in the other ring can definitively establish the spiro-linkage.

Workflow Diagram: From Spectral Complexity to Structural Clarity

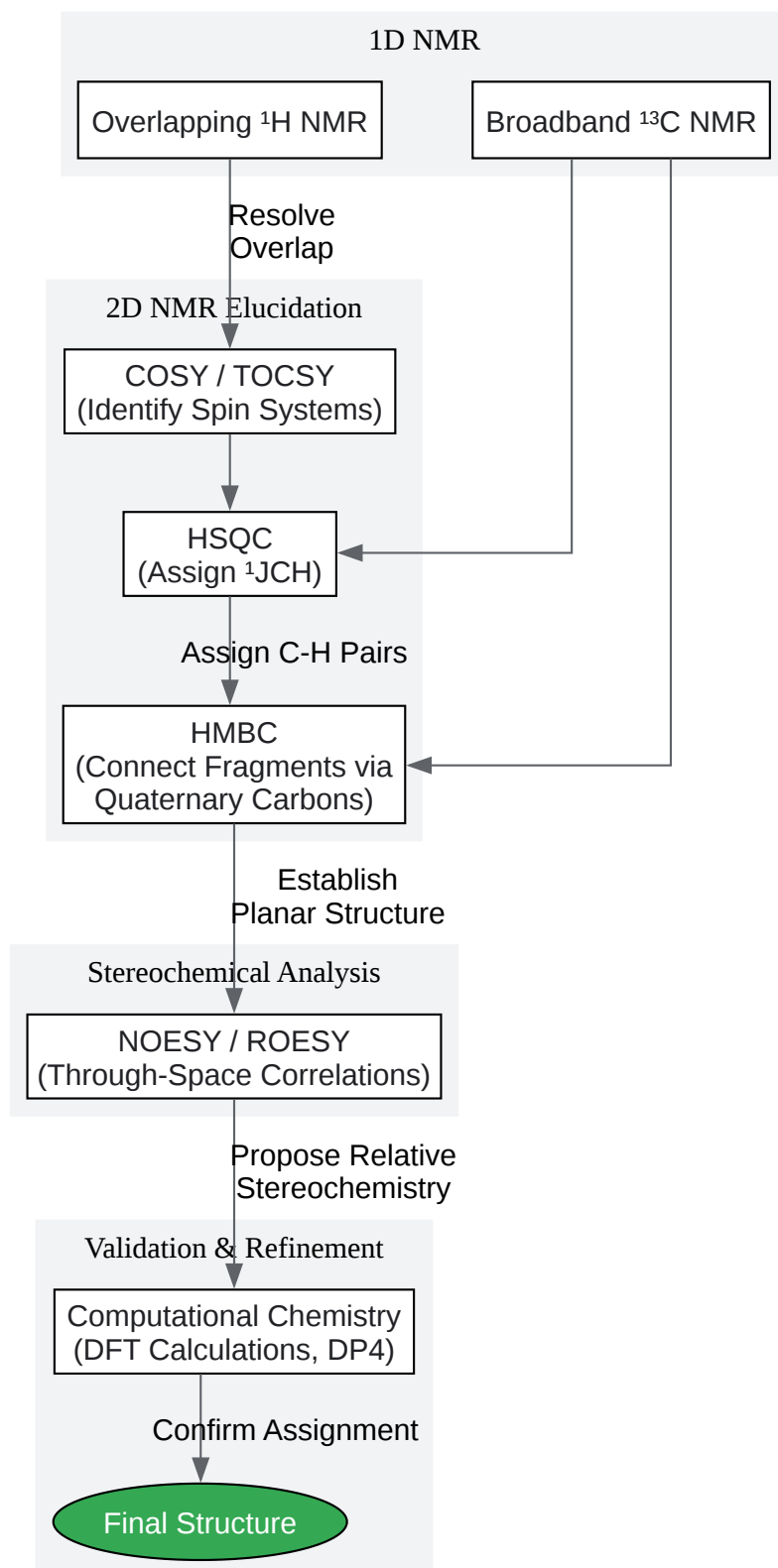

[Click to download full resolution via product page](#)

Caption: A typical workflow for elucidating spirocycle structures.

Q2: I'm struggling to differentiate between diastereotopic protons on a methylene (-CH₂) group adjacent to the spirocenter. What's the best approach?

A2: Understanding and Resolving Diastereotopicity

The spirocenter is a classic source of chirality. Even in an achiral molecule, the presence of a stereocenter renders the two protons of an adjacent methylene group chemically and magnetically inequivalent. These are known as diastereotopic protons. They will have different chemical shifts ($\Delta\delta$), couple to each other (geminal coupling, $^2J_{HH}$), and show different coupling constants to neighboring protons.

Causality: The rigid spirocyclic framework locks these protons into different spatial environments. One proton (e.g., H_a) might be axial-like and closer to one ring system, while the other (H_e) is equatorial-like and points towards a different region of space. This fixed, distinct environment is the root cause of their different chemical shifts.

Troubleshooting Protocol:

- Confirm Diastereotopicity: In the ¹H NMR, look for two separate multiplets that integrate to one proton each, and which show a geminal coupling in the COSY spectrum. In the HSQC, both of these proton signals will correlate to the same carbon signal.
- Assign Individual Protons: The key is to leverage through-space correlations.
 - NOESY/ROESY: This is the most powerful tool.^{[9][10]} One diastereotopic proton will be physically closer to certain protons on an adjacent ring or substituent, while its geminal partner will be closer to others. For example, the "axial" proton might show a strong NOE to another axial proton two bonds away, while the "equatorial" proton does not.
 - Detailed J-Coupling Analysis: In rigid six-membered rings, the magnitude of the vicinal coupling constant ($^3J_{HH}$) is dependent on the dihedral angle (Karplus relationship). An axial-axial coupling is typically large (10-13 Hz), while axial-equatorial and equatorial-equatorial couplings are small (2-5 Hz). By carefully measuring these couplings (which

may require simulation or specialized 1D experiments like PSYCHE), you can often assign the orientation of each proton.[\[11\]](#)

Illustrative Diagram: Diastereotopicity and NOE

Caption: Ha shows a strong NOE to Hx, while Hb does not.

Q3: How can I definitively determine the relative stereochemistry? NOESY seems ambiguous.

A3: Choosing Between NOESY and ROESY for Unambiguous Spatial Information

Determining relative stereochemistry relies on the Nuclear Overhauser Effect (NOE), which is the transfer of polarization between two nuclei that are close in space (typically $< 5 \text{ \AA}$).[\[12\]](#)[\[13\]](#) The strength of the NOE is proportional to $1/r^6$, where r is the internuclear distance, making it extremely sensitive to geometry.

However, NOESY can sometimes provide misleading or absent signals, especially for molecules in the "medium-sized" range (approx. 700-1200 Da). This is because the sign of the NOE effect depends on the molecular tumbling rate (correlation time, τ_c).[\[14\]](#)

- Small Molecules (fast tumbling): Positive NOE. Cross-peaks have the opposite sign to the diagonal peaks.
- Large Molecules (slow tumbling): Negative NOE. Cross-peaks have the same sign as the diagonal peaks.
- Medium-Sized Molecules: The NOE can be close to zero, making signals very weak or undetectable.

Furthermore, in large molecules, NOESY can suffer from spin diffusion. This is where magnetization is relayed sequentially through a chain of protons ($A \rightarrow B \rightarrow C$). This can cause a cross-peak to appear between A and C even if they are far apart, leading to incorrect structural assignments.

ROESY (Rotating-frame Overhauser Effect Spectroscopy) is the solution to these problems. The ROE is always positive, regardless of molecular size.[\[12\]](#) This makes it the experiment of

choice for medium-sized molecules where NOESY fails. ROESY is also less susceptible to spin diffusion.[14]

Feature	NOESY (Nuclear Overhauser Effect Spectroscopy)	ROESY (Rotating-frame Overhauser Effect Spectroscopy)
Mechanism	Dipolar cross-relaxation in the lab frame	Dipolar cross-relaxation in the "rotating frame"
Signal Sign	Positive for small molecules, negative for large	Always positive
Ideal For	Small (<700 Da) or large (>1200 Da) molecules	Medium-sized molecules (700-1200 Da) or any case where NOESY is ambiguous
Artifacts	Prone to spin diffusion in large molecules	TOCSY artifacts can occur, but are usually distinguishable (different phase)

Experimental Protocol: Acquiring High-Quality ROESY Data

- **Sample Preparation:** Ensure the sample is pure and free of paramagnetic impurities (e.g., dissolved O₂, metal contaminants), which quench the ROE.[14] Degassing the sample (e.g., via freeze-pump-thaw cycles) is recommended.
- **Pulse Program:** Use a standard ROESY pulse sequence (e.g., roesyessgp on Bruker systems).
- **Mixing Time (t_m):** This is a critical parameter. It's the period during which the ROE builds up. A mixing time that is too short will result in weak signals; too long, and artifacts can dominate. Run a series of 1D ROESY experiments or 2D ROESYs with varying mixing times (e.g., 100, 200, 300, 500 ms) to find the optimal value for your molecule.
- **Spin-Lock Field:** Use a spin-lock field strength sufficient to prevent Hartmann-Hahn transfers (TOCSY artifacts).

- **Data Processing:** Process the 2D data and carefully phase the spectrum. ROESY cross-peaks should have the opposite phase to the diagonal peaks. TOCSY artifacts will have the same phase as the diagonal.

Q4: My experimental data is still ambiguous. Can computational methods help?

A4: Yes. When experiment alone is not enough, computational chemistry is a powerful validation tool.

Computational methods, particularly Density Functional Theory (DFT), have become indispensable for resolving complex structural ambiguities in NMR.^[15] The process involves comparing experimentally measured NMR parameters (chemical shifts, coupling constants) with those calculated for a set of possible diastereomers. The isomer whose calculated parameters best match the experimental data is the correct one.^{[16][17]}

The DP4 Probability Analysis Workflow:

DP4 (and its newer variants like dJ-DP4) is a statistical method that provides a confidence level for a given structural assignment.^[18] It leverages the fact that errors between calculated and experimental shifts follow a predictable statistical distribution.

Step-by-Step Computational Protocol:

- **Generate Candidate Structures:** Build 3D models of all possible diastereomers of your spirocycle.
- **Conformational Search:** For each diastereomer, perform a thorough conformational search using a low-level method (e.g., molecular mechanics or semi-empirical methods) to identify all low-energy conformers.
- **Geometry Optimization and Energy Calculation:** Re-optimize the geometry of each low-energy conformer using a higher-level DFT method (e.g., B3LYP/6-31G(d,p)). Calculate their relative free energies to determine their contribution to the Boltzmann population.
- **NMR Parameter Calculation:** For each optimized conformer, calculate the ^1H and ^{13}C chemical shifts using a reliable DFT functional and basis set (e.g., mPW1PW91/6-

311+G(2d,p)) employing the GIAO (Gauge-Including Atomic Orbital) method.[15][16]

- Boltzmann Averaging: Calculate the final predicted NMR spectrum for each diastereomer by taking a Boltzmann-weighted average of the chemical shifts of its constituent conformers.
- DP4 Analysis: Input the experimental chemical shifts and the calculated chemical shifts for all candidate diastereomers into a DP4 analysis tool. The output will be a probability score for each candidate, allowing for a highly confident assignment.

This computational approach is particularly powerful for spirocycles, where subtle changes in stereochemistry can lead to significant, but difficult-to-predict, changes in the NMR spectrum.

[19][20]

Frequently Asked Questions (FAQs)

- Q: What fundamentally makes the NMR spectra of spirocycles so complex?
 - A: The primary reasons are their conformational rigidity and unique three-dimensional shape. This rigidity locks protons and carbons into fixed, inequivalent environments, leading to a large number of distinct signals and the common appearance of diastereotopic protons. The sp³-rich nature of many spirocycles also means there are fewer deshielded aromatic signals and more signals in the crowded 1-4 ppm region of the ¹H spectrum.[1]
- Q: When should I absolutely choose ROESY over NOESY?
 - A: You should prioritize ROESY when your molecule's molecular weight is in the ~700-1200 Da range, where the NOE can become zero.[12][14] It is also the better choice if you suspect spin diffusion is giving you false-positive correlations in a NOESY spectrum, which is more common for larger molecules.
- Q: How useful are J-coupling constants for stereochemistry in spirocycles?
 - A: Very useful, provided the ring system is rigid (e.g., a six-membered ring in a chair conformation). The ³J_{HH} coupling constant is related to the H-C-C-H dihedral angle via the Karplus equation. Large couplings (~10-13 Hz) suggest a diaxial relationship (180° angle), while small couplings (~2-5 Hz) suggest axial-equatorial or equatorial-equatorial

relationships ($\sim 60^\circ$ or 90° angles).[21][22] This can be a powerful complement to NOE data.

- Q: What is the specific role of ^{13}C NMR in spirocycle characterization?
 - A: Beyond confirming the number of unique carbons, ^{13}C NMR is critical for identifying the quaternary spiro-carbon, which is a key structural landmark.[23] This carbon will be visible in a standard ^{13}C spectrum but will have no correlation in an HSQC or DEPT-135 spectrum. Its position can be confirmed by looking for long-range HMBC correlations from protons on both rings to this quaternary carbon.
- Q: Are there any specialized NMR experiments for identifying the spiro-carbon?
 - A: The HMBC experiment is the standard and most effective method. For extremely challenging cases where HMBC is ambiguous, experiments like 1,1-ADEQUATE or INADEQUATE can be used. These experiments show direct carbon-carbon correlations, which could, in principle, directly show the connectivity of the spiro-carbon to its four neighbors, but they suffer from extremely low sensitivity and are rarely necessary for small molecules.[24]

References

- Khalilov, L. M., et al. (2011). ^1H and ^{13}C NMR chemical shift assignments of spiro-cycloalkylidenehomo- and methanofullerenes by the DFT-GIAO method. *Magnetic Resonance in Chemistry*, 49(6), 378-84. [\[Link\]](#)
- Decatur, J. (2018). NOESY and ROESY. University of New Hampshire. [\[Link\]](#)
- Organic Spectroscopy International. (2014). NOESY and ROESY. [\[Link\]](#)
- Merrill, A. T., et al. (2023). NMR Prediction with Computational Chemistry. ResearchGate. [\[Link\]](#)
- Chemical Reviews. (2024). Exploring the Frontiers of Computational NMR: Methods, Applications, and Challenges. ACS Publications. [\[Link\]](#)

- MDPI. (2020). Straightforward Synthetic Approach to Aminoalcohols with 9-oxabicyclo[3.3.1]nonane or Cyclooctane Core via Nucleophilic Ring-Opening of Spirocyclic Bis(oxiranes). *Molecules*. [\[Link\]](#)
- Moser, A. (n.d.). Stereochemistry Information from NOESY/ROESY data ... Part 1. ACD/Labs. [\[Link\]](#)
- Reich, H. (n.d.). Organic Chemistry Data: 13C NMR Chemical Shifts. [\[Link\]](#)
- Silva, A. M. S., et al. (n.d.). Advanced NMR techniques for structural characterization of heterocyclic structures. University of Aveiro. [\[Link\]](#)
- Semantic Scholar. (n.d.). Advanced NMR techniques for structural characterization of heterocyclic structures. [\[Link\]](#)
- ResearchGate. (n.d.). (PDF) 8 Advanced NMR techniques for structural characterization of heterocyclic structures. [\[Link\]](#)
- YouTube. (2020). 2D NMR spectroscopy for structural elucidation of complex small molecules. [\[Link\]](#)
- Moser, A. (2009). Stereochemistry Information from NOESY/ROESY data ... Part 2. ACD/Labs. [\[Link\]](#)
- ResearchGate. (2011). H-1 and C-13 NMR chemical shift assignments of spiro-cycloalkylidenehomo- and methanofullerenes by the DFT-GIAO method | Request PDF. [\[Link\]](#)
- ResearchGate. (n.d.). Figure 2. A. 2D NMR correlations plotted on the provisional structure... [\[Link\]](#)
- Royal Society of Chemistry. (n.d.). ¹H NMR spectrum of the spiro compound 18. [\[Link\]](#)
- Scilit. (2026). Spirocyclic compound NMR challenge. *Analytical and Bioanalytical Chemistry*. [\[Link\]](#)

- PubMed. (2012). Structure elucidation from 2D NMR spectra using the StrucEluc expert system: detection and removal of contradictions in the data. [[Link](#)]
- MDPI. (2021). Computational Chemistry in Nuclear Magnetic Resonance. Magnetochemistry. [[Link](#)]
- Nanalysis. (2021). NOESY: the experiment for when you just need to know more, particularly the ^1H - ^1H spatial proximity. [[Link](#)]
- PubMed. (2013). NMR spectroscopy: structure elucidation of cycloelatanene A: a natural product case study. [[Link](#)]
- Reddit. (2022). Advanced NMR techniques. r/Chempros. [[Link](#)]
- Scribd. (n.d.). 2D NMR Spectroscopy for Organic Compounds | PDF. [[Link](#)]
- ETH Zurich. (n.d.). Structure Elucidation by NMR. [[Link](#)]
- MDPI. (2018). NMR of Natural Products as Potential Drugs. Molecules. [[Link](#)]
- Emery Pharma. (2012). Assignment of Complex NMR Spectra-Chemistry Services. [[Link](#)]
- Technology Networks. (2024). NMR Spectroscopy Principles, Interpreting an NMR Spectrum and Common Problems. [[Link](#)]
- Bruker. (n.d.). Natural Products. [[Link](#)]
- ResearchGate. (2013). NMR Spectroscopy: Structure Elucidation of Cycloelatanene A: A Natural Product Case Study | Request PDF. [[Link](#)]
- RSC Publishing. (n.d.). Total syntheses of natural products containing spirocarbocycles. [[Link](#)]
- University of Naples Federico II. (2008). J-COUPPING ANALYSIS AS A MEANS FOR STEREOCHEMICAL ASSIGNMENTS IN FURANOSIDES. [[Link](#)]
- Costantino, V., et al. (2009). J-Coupling Analysis as a Means for Stereochemical Assignments in Furanosides. European Journal of Organic Chemistry. [[Link](#)]

- ACS Publications. (2019). Spirocycles as Rigidified sp³-Rich Scaffolds for a Fragment Collection. *Organic Letters*. [[Link](#)]
- ACS Publications. (2021). Spirocyclic Scaffolds in Medicinal Chemistry. *Journal of Medicinal Chemistry*. [[Link](#)]
- Chemistry LibreTexts. (2023). 13.7: More Complex Spin-Spin Splitting Patterns. [[Link](#)]
- MDPI. (2022). Resolving Entangled JH-H-Coupling Patterns for Steroidal Structure Determinations by NMR Spectroscopy. *Molecules*. [[Link](#)]

Need Custom Synthesis?

BenchChem offers custom synthesis for rare earth carbides and specific isotopic labeling.

Email: info@benchchem.com or [Request Quote Online](#).

Sources

- 1. pubs.acs.org [pubs.acs.org]
- 2. pubs.acs.org [pubs.acs.org]
- 3. chem.libretexts.org [chem.libretexts.org]
- 4. m.youtube.com [m.youtube.com]
- 5. scribd.com [scribd.com]
- 6. emerypharma.com [emerypharma.com]
- 7. Structure Elucidation by NMR – NMR Service | ETH Zurich [nmrservice.ethz.ch]
- 8. researchgate.net [researchgate.net]
- 9. acdlabs.com [acdlabs.com]
- 10. acdlabs.com [acdlabs.com]
- 11. mdpi.com [mdpi.com]
- 12. ORGANIC SPECTROSCOPY INTERNATIONAL: NOESY and ROESY [orgspectroscopyint.blogspot.com]
- 13. NOESY: the experiment for when you just need to know more, particularly the 1H-1H spatial proximity — Nanalysis [nanalysis.com]

- [14. nmr.chem.columbia.edu \[nmr.chem.columbia.edu\]](http://nmr.chem.columbia.edu)
- [15. Exploring the Frontiers of Computational NMR: Methods, Applications, and Challenges - PMC \[pmc.ncbi.nlm.nih.gov\]](https://pubmed.ncbi.nlm.nih.gov/31111111/)
- [16. ¹H and ¹³C NMR chemical shift assignments of spiro-cycloalkylidenehomo- and methanofullerenes by the DFT-GIAO method - PubMed \[pubmed.ncbi.nlm.nih.gov\]](https://pubmed.ncbi.nlm.nih.gov/31111111/)
- [17. researchgate.net \[researchgate.net\]](https://www.researchgate.net)
- [18. comporgchem.com \[comporgchem.com\]](http://comporgchem.com)
- [19. researchgate.net \[researchgate.net\]](https://www.researchgate.net)
- [20. mdpi.com \[mdpi.com\]](http://mdpi.com)
- [21. J-COUPLING ANALYSIS AS A MEANS FOR STEREOCHEMICAL ASSIGNMENTS IN FURANOSIDES \[iris.unina.it\]](https://iris.unina.it)
- [22. J-Coupling Analysis as a Means for Stereochemical Assignments in Furanosides \[iris.unina.it\]](https://iris.unina.it)
- [23. organicchemistrydata.org \[organicchemistrydata.org\]](http://organicchemistrydata.org)
- [24. Natural Products | Bruker \[bruker.com\]](http://bruker.com)
- To cite this document: BenchChem. [Technical Support Center: Spirocyclic Compound NMR Interpretation]. BenchChem, [2026]. [Online PDF]. Available at: [\[https://www.benchchem.com/product/b185648/docs#technical-support-center-spirocyclic-compound-nmr-interpretation\]](https://www.benchchem.com/product/b185648/docs#technical-support-center-spirocyclic-compound-nmr-interpretation)

Disclaimer & Data Validity:

The information provided in this document is for Research Use Only (RUO) and is strictly not intended for diagnostic or therapeutic procedures. While BenchChem strives to provide accurate protocols, we make no warranties, express or implied, regarding the fitness of this product for every specific experimental setup.

Technical Support: The protocols provided are for reference purposes. Unsure if this reagent suits your experiment?

Need Industrial/Bulk Grade? [Request Custom Synthesis Quote](#)

BenchChem

Our mission is to be the trusted global source of essential and advanced chemicals, empowering scientists and researchers to drive progress in science and industry.

Contact

Address: 3281 E Guasti Rd

Ontario, CA 91761, United States

Phone: (601) 213-4426

Email: info@benchchem.com

[Contact our Ph.D. Support Team for a compatibility check](#)