

Application Notes and Protocols for the Isomeric Separation of Olopatadine

Author: BenchChem Technical Support Team. **Date:** May 2026

Compound of Interest

Compound Name: Olopatadine, (E)-

CAS No.: 113806-06-7

Cat. No.: B185939

[Get Quote](#)

Authored by: A Senior Application Scientist

Abstract

This comprehensive technical guide provides detailed methodologies for the separation of olopatadine isomers. Olopatadine, a potent antihistamine and mast cell stabilizer, exists as geometric (E/Z) isomers due to a double bond in its structure.[1][2] The therapeutically active component is the (Z)-isomer, while the (E)-isomer is considered a process-related impurity that must be monitored and controlled according to regulatory standards.[1] This document offers in-depth protocols for High-Performance Liquid Chromatography (HPLC), the principal technique for this analysis, and discusses Capillary Electrophoresis (CE) as a high-efficiency alternative. The guide is designed for researchers, analytical scientists, and drug development professionals, providing not just step-by-step instructions but also the scientific rationale behind the experimental choices to ensure robust and reliable results.

Introduction: The Imperative for Isomeric Purity of Olopatadine

Olopatadine hydrochloride is a second-generation H1 antagonist widely used in ophthalmic and nasal formulations to treat allergic conjunctivitis and rhinitis.[3][4] Its efficacy stems from a dual mechanism of action: selective histamine H1 receptor antagonism and stabilization of mast cells, which inhibits the release of inflammatory mediators.[3][5]

The molecule's chemical structure, 11-[(Z)-3-(Dimethylamino)propylidene]-6,11-dihydrodibenz[b,e]oxepin-2-acetic acid, contains an exocyclic carbon-carbon double bond that gives rise to geometric isomerism.[1][3] The pharmacologically active drug substance is the (Z)-isomer. The corresponding (E)-isomer is a known impurity that can form during synthesis or degradation.[1][4] Regulatory bodies mandate strict control over such impurities to ensure the safety, efficacy, and quality of the final drug product. Therefore, a robust, validated analytical method capable of resolving and quantifying the (Z)-olopatadine from its (E)-isomer is critical in pharmaceutical development and quality control.

This guide details the principles and provides validated protocols for the separation of these isomers, focusing on the widely adopted HPLC technique and exploring the potential of CE.

Analyte Profile: Physicochemical Properties of Olopatadine Hydrochloride

A thorough understanding of the analyte's physicochemical properties is fundamental to developing a successful separation method. These parameters directly influence the choice of column, mobile phase composition, pH, and detection settings.

Property	Value	Significance for Method Development
Molecular Formula	$C_{21}H_{23}NO_3 \cdot HCl$ [5]	Defines the molecule's elemental composition.
Molecular Weight	373.88 g/mol [5]	Basic property for preparing standard solutions of known molarity.
pKa Values	3.78 (carboxylic acid), 9.76 (tertiary amine)[6]	Critical for selecting mobile phase pH to control ionization state, which impacts retention and peak shape.
Solubility	Sparingly soluble in water; soluble in methanol.[5]	Guides the choice of diluent for sample and standard preparation.
UV Absorbance Maxima	~220 nm, ~299 nm[1][4][7]	Determines the optimal wavelength for UV detection to achieve desired sensitivity and specificity.

Primary Technique: High-Performance Liquid Chromatography (HPLC)

Reversed-phase HPLC (RP-HPLC) is the most prevalent and robust method for the analysis of olopatadine and its related substances, including the (E)-isomer.[1][8][9] The separation relies on the differential partitioning of the isomers between a nonpolar stationary phase and a polar mobile phase.

The Science Behind the Separation: Key Parameter Causality

- Column Chemistry: C8 and C18 columns are standard choices.[1][8] These octadecylsilane (C18) or octylsilane (C8) bonded phases provide a hydrophobic surface. The subtle

differences in the three-dimensional shape of the (Z) and (E) isomers lead to slightly different hydrophobic interactions with the stationary phase, enabling their separation.

- **Mobile Phase pH:** With pKa values of 3.78 and 9.76, olopatadine's charge state is highly pH-dependent.[6] To achieve consistent retention and sharp, symmetrical peaks, the mobile phase pH is typically controlled in the acidic range, often around pH 3.0-3.5.[7][8] At this pH, the carboxylic acid group is largely unionized, while the tertiary amine is fully protonated (positively charged), making the molecule suitable for RP-HPLC.
- **Organic Modifier:** Acetonitrile is a common organic modifier used to modulate the elution strength of the mobile phase.[1][7] Adjusting the ratio of acetonitrile to aqueous buffer controls the retention time of the analytes.
- **Ion-Pair Reagents:** To improve the retention and peak shape of the basic olopatadine molecule on a reversed-phase column, an ion-pair reagent such as 1-pentanesulfonic acid sodium salt can be added to the mobile phase.[1] This reagent forms a neutral ion pair with the protonated amine group of olopatadine, increasing its hydrophobicity and retention.
- **Detection Wavelength:** A wavelength of 299 nm provides good specificity for olopatadine.[4] [7] For detecting impurities at very low levels, a lower wavelength like 220 nm may be used to increase sensitivity, although selectivity might be reduced.[1]

Workflow for HPLC Method Development

The following diagram illustrates the logical workflow for developing a robust HPLC separation method for olopatadine isomers.

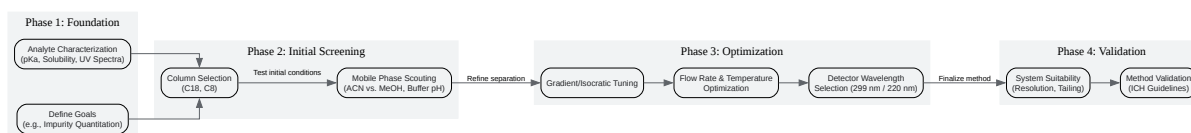

[Click to download full resolution via product page](#)

Caption: Logical workflow for olopatadine HPLC method development.

Application Protocol 1: RP-HPLC for Olopatadine Isomer Separation

This protocol is based on established methods, including those referenced by the USP, for the determination of olopatadine and its (E)-isomer in ophthalmic solutions.[1][7]

Objective: To separate and quantify (Z)-Olopatadine from its (E)-isomer impurity.

1. Instrumentation

- HPLC system with a quaternary or binary pump, autosampler, column thermostat, and a UV/PDA detector.
- Data acquisition and processing software (e.g., Empower, Chromeleon).

2. Reagents and Materials

- Olopatadine Hydrochloride Reference Standard (USP or equivalent)
- (E)-Isomer of Olopatadine Hydrochloride Reference Standard
- Monobasic Potassium Phosphate (KH_2PO_4), HPLC Grade
- Acetonitrile (ACN), HPLC Grade
- Triethylamine (TEA), HPLC Grade
- Phosphoric Acid (H_3PO_4), ACS Grade
- Water, HPLC Grade or Milli-Q

3. Chromatographic Conditions

Parameter	Setting	Rationale
Column	C18, 150 x 4.6 mm, 3.5 μ m (e.g., Kromasil 100)[1]	Provides necessary hydrophobic interaction for separation.
Mobile Phase	Acetonitrile and Phosphate Buffer (e.g., 28:72 v/v)[7]	Balanced polarity for effective elution and resolution.
Buffer Prep	13.6 g/L KH_2PO_4 with 1.0 mL/L TEA, pH adjusted to 3.0 with H_3PO_4 [7]	pH 3.0 ensures consistent protonation of olopatadine. TEA acts as a peak modifier to reduce tailing.
Flow Rate	1.0 - 1.5 mL/min[1][7]	Optimal flow for efficiency and reasonable run time.
Column Temp.	25°C - 30°C[1][8]	Ensures reproducible retention times.
Detection	UV at 299 nm[7]	Provides good specificity for olopatadine.
Injection Vol.	20 - 30 μ L[7]	Standard volume for analytical HPLC.
Run Time	~20 minutes (or until all components have eluted)	Sufficient to elute the main peak and any impurities.

4. Preparation of Solutions

- Buffer: Dissolve 13.6 g of monobasic potassium phosphate in 1 L of HPLC water. Add 1.0 mL of triethylamine. Adjust the pH to 3.0 ± 0.05 with phosphoric acid.
- Mobile Phase: Mix the prepared Buffer and Acetonitrile in the ratio specified (e.g., 72:28 v/v). Filter through a 0.45 μ m membrane filter and degas before use.
- Diluent: A mixture of water and acetonitrile (50:50 v/v) is often suitable.[9]

- Standard Solution (Z-isomer): Accurately weigh and dissolve Olopatadine HCl RS in Diluent to obtain a final concentration of approximately 100 µg/mL of olopatadine.
- Impurity Stock Solution (E-isomer): Prepare a stock solution of the (E)-isomer standard in Diluent (e.g., 100 µg/mL).
- System Suitability Solution (SSS): Spike the Standard Solution with a small amount of the Impurity Stock Solution to obtain a final (E)-isomer concentration of approximately 1-2 µg/mL. This solution is used to verify the system's ability to separate the two isomers.
- Sample Solution: Dilute the pharmaceutical formulation (e.g., eye drops) with the Diluent to achieve a theoretical olopatadine concentration of 100 µg/mL.

5. Analysis Procedure

- Equilibrate the HPLC system with the Mobile Phase until a stable baseline is achieved.
- Perform a blank injection (Diluent) to ensure no carryover or system peaks interfere.
- Inject the System Suitability Solution five or six times.
- Verify that the System Suitability Criteria are met.
- Inject the Standard Solution.
- Inject the Sample Solution in duplicate.
- Inject the Standard Solution again after a series of sample injections to bracket the samples and confirm system stability.

6. System Suitability and Acceptance Criteria

Parameter	Acceptance Criterion	Purpose
Resolution (Rs)	NLT 2.0 between (Z)-olopatadine and (E)-isomer peaks[7]	Ensures baseline separation of the two critical isomers.
Tailing Factor (T)	NMT 2.0 for the (Z)-olopatadine peak[7]	Confirms good peak shape, which is essential for accurate integration.
RSD (%)	NMT 2.0% for the peak area of (Z)-olopatadine from replicate injections[7]	Demonstrates the precision of the analytical system.

7. Calculation of Impurity The percentage of the (E)-isomer in the sample can be calculated using the following formula:

$$\% \text{ (E)-Isomer} = (\text{Area_E_Sample} / \text{Area_Z_Std}) * (\text{Conc_Z_Std} / \text{Conc_Sample}) * (1 / \text{RRF}) * 100$$

Where:

- Area_E_Sample = Peak area of the (E)-isomer in the sample chromatogram.
- Area_Z_Std = Average peak area of the (Z)-isomer in the standard chromatogram.
- Conc_Z_Std = Concentration of the (Z)-isomer standard (mg/mL).
- Conc_Sample = Concentration of olopatadine in the sample preparation (mg/mL).
- RRF = Relative Response Factor of the (E)-isomer to the (Z)-isomer (must be experimentally determined if not 1.0).

Alternative Technique: Capillary Electrophoresis (CE)

Capillary Electrophoresis (CE), specifically Capillary Zone Electrophoresis (CZE), offers an orthogonal separation mechanism to HPLC and can be a powerful tool for purity analysis.[10]

Its advantages include extremely high separation efficiency, short analysis times, and minimal consumption of solvents and samples.[11] While published methods focus on assaying olopatadine, the high efficiency of the technique suggests strong potential for resolving closely related isomers.[10]

Principle of Separation

In CZE, analytes are separated within a narrow-bore fused-silica capillary based on their charge-to-size ratio when an electric field is applied. Positively charged olopatadine (at acidic or neutral pH) will migrate towards the cathode. Subtle differences in the hydrodynamic radius and charge distribution between the (Z) and (E) isomers could lead to different electrophoretic mobilities, enabling separation.

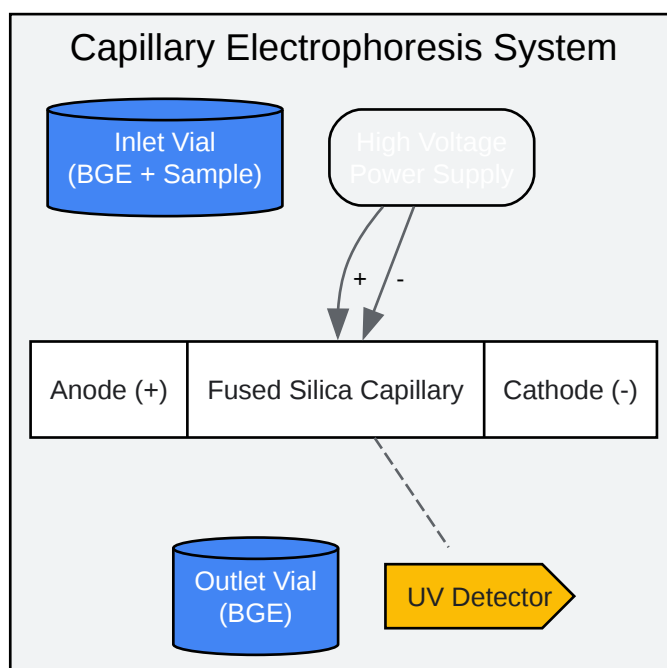

[Click to download full resolution via product page](#)

Caption: Schematic of a Capillary Zone Electrophoresis (CZE) system.

Application Protocol 2: CZE for Olopatadine Analysis

This protocol is adapted from published literature for the analysis of olopatadine in pharmaceutical preparations.[10][12] Optimization would be required to achieve baseline separation of the (E/Z) isomers.

Objective: To establish a high-efficiency method for the purity analysis of olopatadine.

1. Instrumentation

- Capillary Electrophoresis system with a UV/PDA detector.
- Fused-silica capillaries (e.g., 50 μm i.d., ~50-60 cm total length).

2. Reagents and Materials

- Sodium Tetraborate, ACS Grade
- Sodium Chloride (NaCl), ACS Grade
- Acetonitrile (ACN), HPLC Grade
- Sodium Hydroxide (NaOH) and Hydrochloric Acid (HCl) for pH adjustment.
- Water, HPLC Grade or Milli-Q

3. Electrophoretic Conditions

Parameter	Setting	Rationale
Capillary	Fused silica, 50 μm i.d., 50 cm effective length	Standard dimension for high-efficiency CZE.
BGE	20 mmol/L Sodium Tetraborate, 10 mmol/L NaCl, 15% ACN (v/v), pH 9.5[10]	The borate buffer controls pH and ionic strength. ACN modifies selectivity. NaCl reduces wall interactions.
Voltage	+25 kV	High voltage provides rapid separation.
Temperature	30°C[10]	Ensures reproducible migration times.
Injection	Hydrodynamic (Pressure): 50 mbar for 5-10 s	Precise and reproducible sample introduction.
Detection	UV at 205 nm[10]	High absorbance at lower UV wavelengths provides excellent sensitivity.

4. Analysis Procedure

- Condition a new capillary by flushing sequentially with 1 M NaOH, water, and Background Electrolyte (BGE).
- Equilibrate the capillary by flushing with BGE for several minutes.
- Inject a sample of the Olopatadine standard or sample solution.
- Apply the separation voltage and record the electropherogram.
- Between runs, flush the capillary with BGE to ensure reproducible migration times.

Note on Chiral Separations: While olopatadine separation concerns geometric isomers, CE is a premier technique for true chiral (enantiomeric) separations. For chiral drugs, this is achieved by adding a chiral selector (e.g., a cyclodextrin derivative) to the BGE.[13][14] The selector

forms transient diastereomeric complexes with the enantiomers, which have different mobilities, leading to their separation.

Conclusion

The separation of olopatadine's (Z) and (E) isomers is a critical task in ensuring the quality and safety of its pharmaceutical formulations. The detailed RP-HPLC protocol provided in this guide offers a robust, validated, and readily implementable method for routine quality control. The discussion and protocol for Capillary Electrophoresis present a high-efficiency, orthogonal technique valuable for research and advanced analytical challenges. By understanding the scientific principles behind the chosen parameters, researchers can not only execute these protocols effectively but also troubleshoot and adapt them for future applications.

References

- Title: Olopatadine Hydrochloride | Drug Information, Uses, Side Effects, Chemistry Source: [Google Cloud URL](#)
- Title: Advances in Simple and Chiral-HPLC Methods for Antiallergic Drugs and Chiral Recognition Mechanism Source: [MDPI URL](#)
- Title: Formulation of olopatadine hydrochloride viscous eye drops - physicochemical, biopharmaceutical and efficacy assessment using in vitro and in vivo approaches Source: [PubMed URL](#)
- Source: NINGBO INNO PHARMCHEM CO.,LTD.
- Source: apo-olopatadine-pm-en.
- Title: US9533053B2 - High concentration olopatadine ophthalmic composition Source: [Google Patents URL](#)
- Title: UV spectrophotometric methods for simultaneous determination of ketorolac tromethamine and olopatadine hydrochloride: Application of multiple standard addition for assay of ophthalmic solution Source: [PMC - NIH URL](#)
- Title: Application of High Performance Liquid Chromatographic Technique for Olopatadine Hydrochloride and its Impurity in Ophthalmic Solution Source: [TSI Journals URL](#)
- Title: Chromatographic analysis of olopatadine in hydrophilic interaction liquid chromatography Source: [PubMed URL](#)
- Title: Recent Advances in Chiral Separation of Antihistamine Drugs: Analytical and Bioanalytical Methods Source: [PubMed URL](#)
- Title: A Validated Capillary Electrophoretic Method for the Determination of Olopatadine and Its Application to a Pharmaceutical Preparation of Eye Drops Source: [PubMed URL](#)

- Title: Chiral Separation of 12 Pairs of Enantiomers by Capillary Electrophoresis Using heptakis-(2,3-diacetyl-6-sulfato)
- Title: (PDF)
- Source: digital.csic.
- Source: New Journal of Chemistry (RSC Publishing)
- Title: An overview of chiral separations of pharmaceutically active substances by HPLC (2018–2020)
- Title: Green Liquid Chromatography Method for the Determination of Related Substances Present in Olopatadine HCl Nasal Spray Formulation, Robustness by Design Expert Source: PubMed URL
- Title: UHPLC Study on the Degradation Profiles of Olopatadine Hydrochloride in Eye Drops Subjected to Heat and Filtration Methods of Source: SciSpace URL
- Title: Chiral Drug Separation Source: Encyclopedia of Chemical Technology URL
- Title: Reversed phase high performance liquid chromatography method for determination of olopatadine hydrochloride from active pharmaceutical dosage form Source: Scholars Research Library URL
- Title: Chiral Separation and Enantiomeric Analysis: Critical Importance in Pharmaceutical Development Source: American Pharmaceutical Review URL
- Title: Reversed phase high performance liquid chromatography method for determination of olopatadine hydrochloride from active pharmaceutical dosage form | Request PDF Source: ResearchGate URL
- Title: Emerging Developments in Separation Techniques and Analysis of Chiral Pharmaceuticals Source: MDPI URL
- Title: Olopatadine Hydrochloride Ophthalmic Solution Source: USP-NF URL
- Title: Colorimetric Determination of Olopatadine Hydrochloride Oxidation-Reduction Products in Pure form and Eye Drops Source: Austin Publishing Group URL
- Title: UV-Spectrophotometric Estimation of Olopatadine hydrochloride in Bulk and Pharmaceutical Dosage Form by area under Curve and second Order Derivative Methods Source: RJPT URL

Need Custom Synthesis?

BenchChem offers custom synthesis for rare earth carbides and specific isotopic labeling.

Email: info@benchchem.com or [Request Quote Online](#).

Sources

- [1. tsijournals.com \[tsijournals.com\]](https://tsijournals.com)
- [2. Chromatographic analysis of olopatadine in hydrophilic interaction liquid chromatography - PubMed \[pubmed.ncbi.nlm.nih.gov\]](https://pubmed.ncbi.nlm.nih.gov)
- [3. nbinno.com \[nbinno.com\]](https://nbinno.com)
- [4. scispace.com \[scispace.com\]](https://scispace.com)
- [5. pdf.hres.ca \[pdf.hres.ca\]](https://pdf.hres.ca)
- [6. UV spectrophotometric methods for simultaneous determination of ketorolac tromethamine and olopatadine hydrochloride: Application of multiple standard addition for assay of ophthalmic solution - PMC \[pmc.ncbi.nlm.nih.gov\]](https://pubmed.ncbi.nlm.nih.gov)
- [7. uspnf.com \[uspnf.com\]](https://uspnf.com)
- [8. Green Liquid Chromatography Method for the Determination of Related Substances Present in Olopatadine HCl Nasal Spray Formulation, Robustness by Design Expert - PubMed \[pubmed.ncbi.nlm.nih.gov\]](https://pubmed.ncbi.nlm.nih.gov)
- [9. scholarsresearchlibrary.com \[scholarsresearchlibrary.com\]](https://scholarsresearchlibrary.com)
- [10. A Validated Capillary Electrophoretic Method for the Determination of Olopatadine and Its Application to a Pharmaceutical Preparation of Eye Drops - PubMed \[pubmed.ncbi.nlm.nih.gov\]](https://pubmed.ncbi.nlm.nih.gov)
- [11. Emerging Developments in Separation Techniques and Analysis of Chiral Pharmaceuticals - PMC \[pmc.ncbi.nlm.nih.gov\]](https://pubmed.ncbi.nlm.nih.gov)
- [12. researchgate.net \[researchgate.net\]](https://researchgate.net)
- [13. Chiral separation of 12 pairs of enantiomers by capillary electrophoresis using heptakis-\(2,3-diacetyl-6-sulfato\)- \$\beta\$ -cyclodextrin as the chiral selector and the elucidation of the chiral recognition mechanism by computational methods - PubMed \[pubmed.ncbi.nlm.nih.gov\]](https://pubmed.ncbi.nlm.nih.gov)
- [14. researchgate.net \[researchgate.net\]](https://researchgate.net)
- To cite this document: BenchChem. [Application Notes and Protocols for the Isomeric Separation of Olopatadine]. BenchChem, [2026]. [Online PDF]. Available at: [\[https://www.benchchem.com/product/b185939/docs#application-notes-and-protocols-for-the-isomeric-separation-of-olopatadine\]](https://www.benchchem.com/product/b185939/docs#application-notes-and-protocols-for-the-isomeric-separation-of-olopatadine)

Disclaimer & Data Validity:

The information provided in this document is for Research Use Only (RUO) and is strictly not intended for diagnostic or therapeutic procedures. While BenchChem strives to provide

accurate protocols, we make no warranties, express or implied, regarding the fitness of this product for every specific experimental setup.

Technical Support: The protocols provided are for reference purposes. Unsure if this reagent suits your experiment?

Need Industrial/Bulk Grade? [Request Custom Synthesis Quote](#)

BenchChem

Our mission is to be the trusted global source of essential and advanced chemicals, empowering scientists and researchers to drive progress in science and industry.

Contact

Address: 3281 E Guasti Rd

Ontario, CA 91761, United States

Phone: (601) 213-4426

Email: info@benchchem.com

[Contact our Ph.D. Support Team for a compatibility check](#)