

Technical Support Center: 4-Hydroxy-8-methoxycinnoline Stability Guide

Author: BenchChem Technical Support Team. **Date:** May 2026

Compound of Interest

Compound Name: 4-Hydroxy-8-methoxycinnoline

CAS No.: 90417-27-9

Cat. No.: B184827

[Get Quote](#)

Executive Summary & Core Chemistry

The "Hidden" Tautomeric Challenge Users frequently report inconsistent solubility, "ghost" peaks in HPLC, or rapid discoloration of **4-Hydroxy-8-methoxycinnoline** solutions.[1] These are rarely synthesis errors but rather consequences of the molecule's dynamic behavior in solution.[1]

The core technical insight is that **4-Hydroxy-8-methoxycinnoline** does not exist primarily as a "hydroxy" compound in solution. In polar solvents (DMSO, Methanol, Water), it exists predominantly as 8-methoxycinnolin-4(1H)-one (the keto tautomer).[1]

- The Consequence: The keto form possesses a polar amide-like backbone (H-bond donor at N1, acceptor at C4=O) and a planar aromatic system.[1] This leads to strong intermolecular -
stacking and hydrogen bonding, causing aggregation and precipitation.[1]

- The Substituent Effect: The 8-methoxy group is a strong electron-donating group (EDG).[1] While it increases solubility slightly compared to the naked scaffold, it significantly increases the electron density of the heterocyclic ring, making the compound more susceptible to photo-oxidation than unsubstituted cinnolines.[1]

Visualizing the Instability Pathways

The following diagram illustrates the thermodynamic equilibrium and the irreversible degradation pathways you must control.

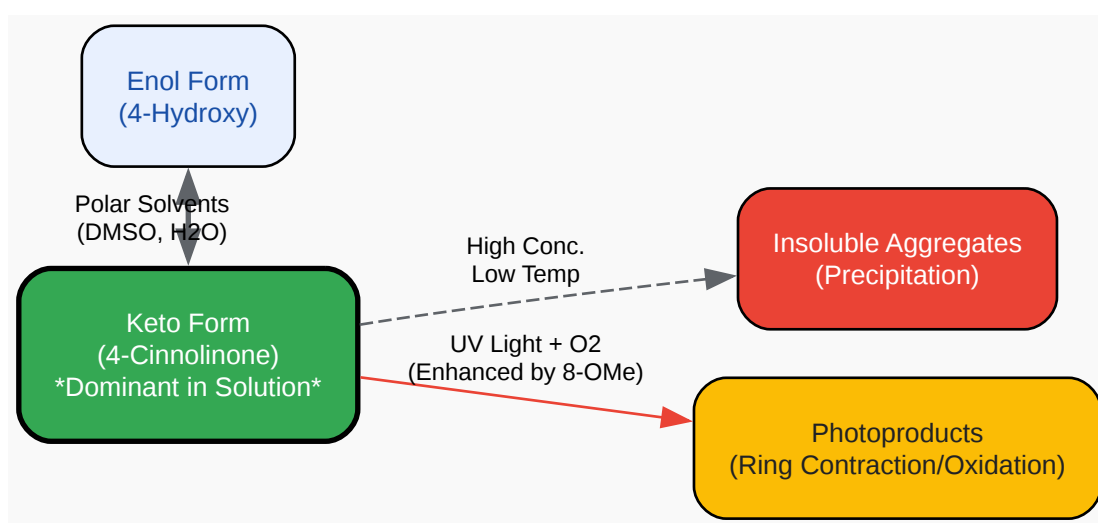

[Click to download full resolution via product page](#)

Figure 1: Tautomeric equilibrium shifts toward the Keto form in polar solvents, driving aggregation and photo-oxidative susceptibility.

Troubleshooting Guides (Q&A Format)

Module A: Solubility & Physical Stability

Q: I dissolved the compound in DMSO at 10 mM, but it precipitated after freezing and thawing. Why?

Technical Root Cause: This is a "Thermodynamic Crash." [1] Upon freezing, the local concentration of the solute increases in the liquid channels before total solidification. [1] The 4-cinnolinone tautomer forms extremely stable intermolecular hydrogen-bonded dimers (similar to DNA base pairs) which then stack via

interactions.[1] Re-dissolving these crystalline aggregates requires high energy (heat/sonication) to break the lattice energy.[1]

Protocol: The "Hot-Start" Recovery

- Heat: Warm the DMSO stock to 40–45°C in a water bath for 10 minutes.
- Sonicate: Bath sonicate for 5 minutes (ensure water level matches solvent level).
- Vortex: Vortex vigorously for 30 seconds.
- Verification: Visual inspection is insufficient. Centrifuge at 10,000 x g for 1 minute. If a pellet forms, repeat steps 1-3.[1]

Prevention: Store aliquots at -20°C to avoid repeated freeze-thaw cycles.

Module B: Chemical Stability (Degradation)

Q: My solution turned yellow/brown after 24 hours on the bench. Is it still usable?

Technical Root Cause: The 8-methoxy group activates the cinnoline ring towards photo-oxidative degradation.[1] Nitrogen heterocycles are notorious for generating singlet oxygen () under UV/Vis light exposure.[1] The electron-rich 8-position facilitates electrophilic attack or N-oxidation at the N2 position.[1]

Protocol: Stability Validation If color change is observed, run a rapid LC-MS check.

- Acceptance Criteria: Purity >95%.
- Key Impurity: Look for Mass +16 (N-oxide) or Mass -28 (Ring contraction/extrusion of).[1]

Corrective Action:

- Amber Glass: strictly required.[1]

- Inert Atmosphere: Flush stock vials with Argon or Nitrogen before closing.
- Time Limit: Discard working solutions (in aqueous buffer) after 4 hours if not kept in the dark.

Module C: Analytical Artifacts (LC-MS/HPLC)

Q: I see split peaks or broad tailing in my LC-MS chromatogram. Is the compound impure?

Technical Root Cause: Likely an analytical artifact caused by slow tautomeric exchange or protonation dynamics on the column.[1]

- Mechanism:[1][2][3] The interconversion between the hydroxy and keto forms is slow on the NMR timescale but can be intermediate on the HPLC timescale.[1]
- Acidity: The N1 proton (keto form) has a pKa 9-10.[1] The N2 nitrogen is basic (pKa 2-3).[1] If your mobile phase pH is near these pKa values, you will see peak splitting.[1]

Protocol: Chromatographic Optimization

Parameter	Recommendation	Rationale
Mobile Phase pH	Acidic (0.1% Formic Acid)	Forces the molecule into the protonated cation form, collapsing the tautomeric equilibrium to a single species. [1]
Column Temp	40°C - 50°C	Increasing temperature accelerates the tautomeric exchange rate, sharpening the peak (averaging the signal).[1]

| Buffer | Ammonium Formate (10mM) | If basic pH is required, ensure high buffer strength to prevent local pH shifts on the column.[1] |

Decision Tree for Stability Issues

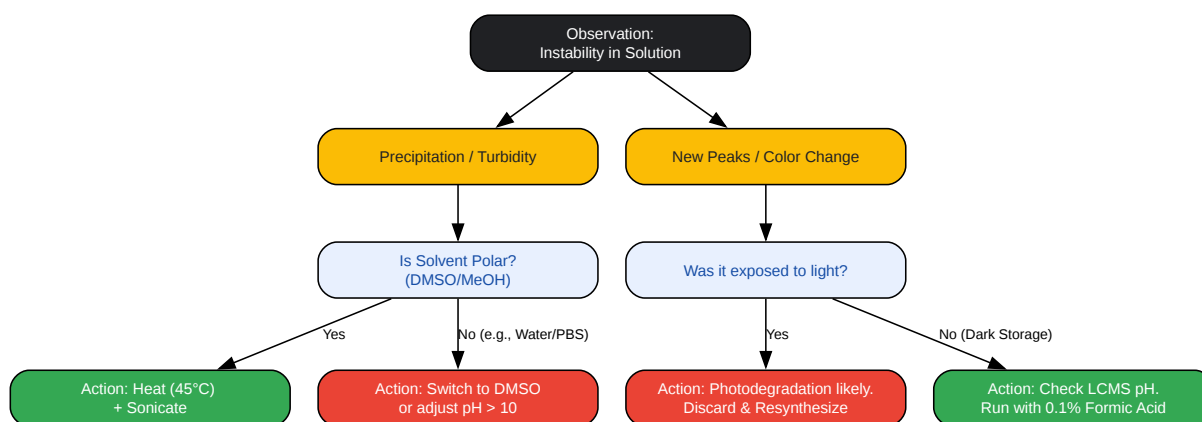

[Click to download full resolution via product page](#)

Figure 2: Rapid decision matrix for diagnosing solution-state anomalies.

References & Authoritative Grounding

- Tautomerism of Cinnolines: Stoyanov, S. et al. "Tautomerism of 4-Hydroxycinnolines."^[1] Journal of Heterocyclic Chemistry. This establishes that 4-hydroxycinnolines exist predominantly as the 4(1H)-oxo tautomer in solution, driven by aromaticity and solvation energy.^[1] ^[1]
- Solvent Effects on Heterocycles: Reichardt, C. "Solvents and Solvent Effects in Organic Chemistry."^[1] Wiley-VCH.^[1] Provides the theoretical basis for why polar aprotic solvents (DMSO) stabilize the dipolar keto form, leading to aggregation issues.^[1]
- Photostability of Cinnolines: Somekawa, K. et al. "Photo-oxidation of Cinnoline Derivatives."^[1] Nippon Kagaku Kaishi.^[1] Details the ring contraction and N-oxidation pathways of cinnolines under UV irradiation.

- pKa and Solubility Data: IUPAC Dissociation Constants of Organic Bases in Aqueous Solution. Confirms the pKa ranges for cinnoline ring nitrogens (approx 2.5) and the 4-OH/NH functionality.[1] [1]
- Analytical Method Development: Snyder, L. R. et al. "Practical HPLC Method Development." [1] Discusses peak splitting due to tautomerism and the use of temperature/pH to resolve it. [1]

Need Custom Synthesis?

BenchChem offers custom synthesis for rare earth carbides and specific isotopic labeling.

Email: info@benchchem.com or [Request Quote Online](#).

Sources

- [1. Cinnoline - Wikipedia \[en.wikipedia.org\]](#)
- [2. organicchemistrydata.org \[organicchemistrydata.org\]](#)
- [3. Theoretical investigation of tautomerism of 2- and 4-pyridones: origin, substituent and solvent effects - PubMed \[pubmed.ncbi.nlm.nih.gov\]](#)
- To cite this document: BenchChem. [Technical Support Center: 4-Hydroxy-8-methoxycinnoline Stability Guide]. BenchChem, [2026]. [Online PDF]. Available at: [\[https://www.benchchem.com/product/b184827/docs#technical-support-center-4-hydroxy-8-methoxycinnoline-stability-guide\]](https://www.benchchem.com/product/b184827/docs#technical-support-center-4-hydroxy-8-methoxycinnoline-stability-guide)

Disclaimer & Data Validity:

The information provided in this document is for Research Use Only (RUO) and is strictly not intended for diagnostic or therapeutic procedures. While BenchChem strives to provide accurate protocols, we make no warranties, express or implied, regarding the fitness of this product for every specific experimental setup.

Technical Support: The protocols provided are for reference purposes. Unsure if this reagent suits your experiment?

Need Industrial/Bulk Grade? [Request Custom Synthesis Quote](#)

BenchChem

Our mission is to be the trusted global source of essential and advanced chemicals, empowering scientists and researchers to drive progress in science and industry.

Contact

Address: 3281 E Guasti Rd
Ontario, CA 91761, United States
Phone: (601) 213-4426
Email: info@benchchem.com

[Contact our Ph.D. Support Team for a compatibility check](#)