

# Structure-Activity Relationship (SAR) of Phenethyl Ester Parabens: A Technical Guide

**Author:** BenchChem Technical Support Team. **Date:** May 2026

## Compound of Interest

Compound Name: Phenethyl 4-hydroxybenzoate  
CAS No.: 83936-28-1  
Cat. No.: B183821

Get Quote

## Executive Summary

This technical guide analyzes the structure-activity relationship (SAR) of Phenethyl Paraben (**Phenethyl 4-hydroxybenzoate**), a specialized aryl-alkyl ester within the paraben family. Unlike common linear alkyl parabens (methyl-, ethyl-, propyl-), the phenethyl analog incorporates a bulky, aromatic tail group. This structural modification significantly alters its lipophilicity (

), receptor binding affinity, and antimicrobial spectrum. This guide is designed for drug development professionals seeking to understand the mechanistic trade-offs between antimicrobial potency and endocrine disruption potential in aryl-substituted preservatives.[1]

## Part 1: Molecular Architecture & Physicochemical Properties[1]

The core paraben scaffold consists of a 4-hydroxybenzoic acid head group linked to an ester tail.[1] The SAR of phenethyl paraben is defined by the 2-phenylethyl moiety.[1]

## Structural Comparison

- Head Group (Invariant): Phenolic hydroxyl ( ) at the para position. Responsible for hydrogen bonding and weak acidity ( ).<sup>[1]</sup>
- Linker (Invariant): Ester bond.<sup>[1][2]</sup> Susceptible to hydrolysis by esterases.<sup>[1]</sup>
- Tail Group (Variant):
  - Methyl Paraben:<sup>[3][4][5]</sup> Short, linear alkyl ( ). Low lipophilicity.<sup>[1]</sup>
  - Phenethyl Paraben: Bulky, aromatic aryl-alkyl ( ). High lipophilicity and steric volume.<sup>[1]</sup>

## Physicochemical Data Matrix

The addition of the phenethyl group drastically shifts the physicochemical profile compared to the standard methyl analog.

Property	Methyl Paraben (Reference)	Phenethyl Paraben (Target)	SAR Implication
Formula			Increased molecular weight affects diffusion rates.
LogP (Lipophilicity)	~1.96	~4.2 (Predicted)	High membrane permeability; potential for bioaccumulation. [1]
Water Solubility	~2500 mg/L	< 10 mg/L (Est.)	Requires solubilizers (e.g., glycols) in formulation.
Steric Bulk	Low	High	Enhanced Van der Waals interactions in receptor pockets.[1]
-System	Single ring (Head)	Dual ring (Head + Tail)	Potential for stacking in protein binding sites.[1]

## Part 2: Antimicrobial Efficacy (The Desired Activity)

The antimicrobial mechanism of parabens relies on membrane disruption and inhibition of membrane transport processes.[1] The SAR follows a parabolic relationship with lipophilicity (Hansch analysis).[1]

### Mechanism of Action

Phenethyl paraben exhibits superior potency against Gram-positive bacteria compared to shorter chains due to its ability to partition deeply into the lipid bilayer.[1]

- Adsorption: The hydrophobic phenethyl tail anchors into the bacterial cell membrane.[1]
- Disruption: The molecule interferes with the packing of membrane lipids, increasing fluidity and leakage.[1][2]

- Collapse: Disruption of the proton motive force (PMF) leads to inhibition of active transport and eventual cell death.[1]

## Visualization: Membrane Interaction Pathway[1]

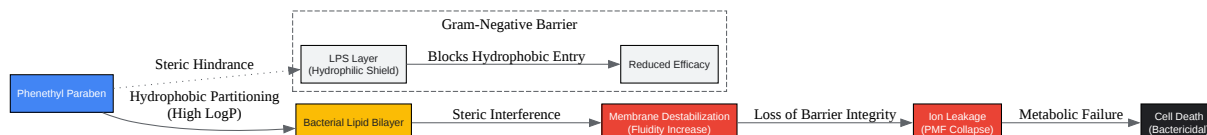

[Click to download full resolution via product page](#)

Figure 1: Mechanism of membrane disruption. The high lipophilicity of the phenethyl group facilitates deep membrane penetration, critical for Gram-positive efficacy.

## Part 3: Endocrine Toxicology (The Undesired Activity)

The "Paraben Paradox" states that increasing chain length improves antimicrobial efficacy but simultaneously increases estrogenic potential.[1] Phenethyl paraben represents a critical point in this SAR due to its structural similarity to

-estradiol.[1]

### Estrogen Receptor (ER) Docking SAR

- Pharmacophore Mimicry: The phenolic ring of the paraben mimics the A-ring of estradiol.[1]
- Hydrophobic Pocket Binding: The Estrogen Receptor (ER ) ligand-binding domain (LBD) contains a large hydrophobic pocket.[1]
- Phenethyl Specificity: Unlike linear propyl/butyl chains, the phenethyl group is aromatic.[1] This allows it to engage in

stacking interactions with aromatic residues (e.g., Phenylalanine, Tyrosine) within the LBD, potentially stabilizing the active conformation of the receptor more effectively than aliphatic analogs.

## Visualization: Estrogenic Activation Pathway[1]

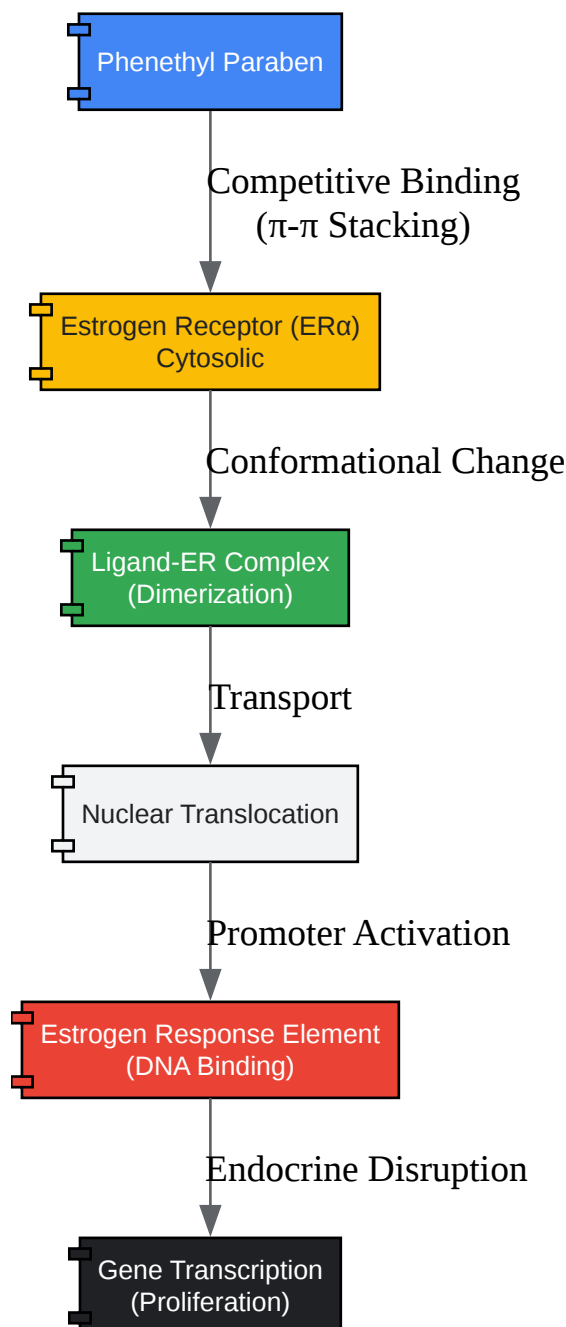

[Click to download full resolution via product page](#)

Figure 2: Estrogenic signaling pathway. The aromatic tail of phenethyl paraben enhances affinity for the ER hydrophobic pocket, triggering transcription.

## Part 4: Synthesis Protocol (Steglich Esterification)

While Fischer esterification is common, the high boiling point of 2-phenylethanol (

) makes removal of excess alcohol difficult. A Steglich Esterification using DCC (N,N'-dicyclohexylcarbodiimide) is recommended for research-grade purity as it proceeds under mild conditions.[1]

### Reagents[1][7]

- Substrate: 4-Hydroxybenzoic acid (1.0 eq)
- Alcohol: 2-Phenylethanol (1.1 eq)[1]
- Coupling Agent: DCC (1.1 eq)
- Catalyst: DMAP (4-Dimethylaminopyridine) (0.1 eq)
- Solvent: Dichloromethane (DCM) or DMF (anhydrous)[1]

### Step-by-Step Methodology

- Preparation: Dissolve 4-hydroxybenzoic acid (13.8 g, 100 mmol) and 2-phenylethanol (13.4 g, 110 mmol) in anhydrous DCM (250 mL) under nitrogen atmosphere.
- Catalyst Addition: Add DMAP (1.2 g, 10 mmol) to the solution.
- Coupling: Cool the reaction mixture to  
  
in an ice bath. Add DCC (22.7 g, 110 mmol) dissolved in minimal DCM dropwise over 30 minutes.
- Reaction: Allow the mixture to warm to room temperature and stir for 12–24 hours. A white precipitate (dicyclohexylurea, DCU) will form.[1]
- Work-up:

- Filter off the DCU precipitate.[1]
- Wash the filtrate with 1N HCl (to remove DMAP), saturated (to remove unreacted acid), and brine.
- Dry the organic layer over anhydrous and concentrate in vacuo.
- Purification: Recrystallize from ethanol/water or purify via silica gel column chromatography (Hexane:Ethyl Acetate 8:2) to yield **Phenethyl 4-hydroxybenzoate**. [1][6]

## Synthesis Workflow Diagram

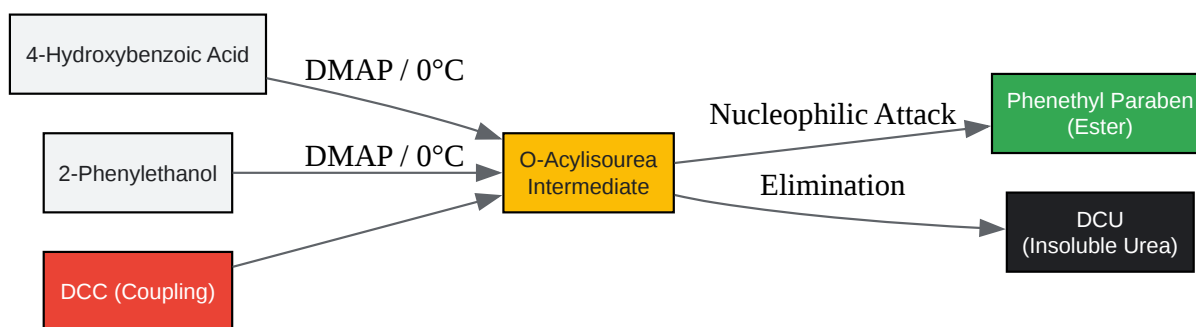

[Click to download full resolution via product page](#)

Figure 3: Steglich esterification pathway. DCC activates the carboxylic acid, facilitating attack by the phenethyl alcohol under mild conditions.

## Part 5: Analytical Validation

To validate the synthesis and study the SAR, the following analytical parameters must be confirmed.

Method	Expected Signal (Phenethyl Paraben)	Diagnostic Value
HPLC-UV	Retention time > Propyl/Butyl Paraben (C18 Column)	Confirms high hydrophobicity. [1]
1H NMR	Multiplet at 7.2-7.4 ppm (5H, aromatic tail)	Confirms presence of phenethyl ring.
1H NMR	Triplet at 4.5 ppm (2H, )	Confirms ester linkage.
Mass Spec	Molecular Ion at 241	Confirms molecular weight ( ).

## References

- Soni, M. G., et al. (2005).[1] "Safety assessment of propyl paraben: a review of the literature." Food and Chemical Toxicology. [Link](#)
- Routledge, E. J., et al. (1998).[1] "Some alkyl hydroxy benzoate preservatives (parabens) are estrogenic." [1][7] Toxicology and Applied Pharmacology. [Link](#)
- Hansch, C., & Clayton, J. M. (1973).[1] "Lipophilic character and biological activity of drugs II: The parabolic case." Journal of Pharmaceutical Sciences. [Link](#)
- PubChem. (2024).[1] "4-Hydroxybenzoic acid (Compound CID 135)."[1] National Library of Medicine.[1] [Link](#)
- Neises, B., & Steglich, W. (1978).[1] "Simple Method for the Esterification of Carboxylic Acids." Angewandte Chemie International Edition. [Link](#)

### Need Custom Synthesis?

BenchChem offers custom synthesis for rare earth carbides and specific isotopic labeling.

Email: [info@benchchem.com](mailto:info@benchchem.com) or [Request Quote Online](#).

## Sources

- [1. p-Hydroxybenzoate | C7H5O3- | CID 54675830 - PubChem \[pubchem.ncbi.nlm.nih.gov\]](#)
- [2. Parabens Permeation through Biological Membranes: A Comparative Study Using Franz Cell Diffusion System and Biomimetic Liquid Chromatography - PMC \[pmc.ncbi.nlm.nih.gov\]](#)
- [3. ueno-fc.co.jp \[ueno-fc.co.jp\]](#)
- [4. ijrtdt.org \[ijrtdt.org\]](#)
- [5. Role of Propylparaben & Methylparaben in Product Preservation \[elchemy.com\]](#)
- [6. EP1009758B1 - Meta-benzamidine derivatives as serine protease inhibitors - Google Patents \[patents.google.com\]](#)
- [7. Final amended report on the safety assessment of Methylparaben, Ethylparaben, Propylparaben, Isopropylparaben, Butylparaben, Isobutylparaben, and Benzylparaben as used in cosmetic products - PubMed \[pubmed.ncbi.nlm.nih.gov\]](#)
- To cite this document: BenchChem. [Structure-Activity Relationship (SAR) of Phenethyl Ester Parabens: A Technical Guide]. BenchChem, [2026]. [Online PDF]. Available at: [\[https://www.benchchem.com/product/b183821/docs#structure-activity-relationship-sar-of-phenethyl-ester-parabens-a-technical-guide\]](https://www.benchchem.com/product/b183821/docs#structure-activity-relationship-sar-of-phenethyl-ester-parabens-a-technical-guide)

---

### Disclaimer & Data Validity:

The information provided in this document is for Research Use Only (RUO) and is strictly not intended for diagnostic or therapeutic procedures. While BenchChem strives to provide accurate protocols, we make no warranties, express or implied, regarding the fitness of this product for every specific experimental setup.

**Technical Support:** The protocols provided are for reference purposes. Unsure if this reagent suits your experiment?

**Need Industrial/Bulk Grade?** [Request Custom Synthesis Quote](#)

# BenchChem

Our mission is to be the trusted global source of essential and advanced chemicals, empowering scientists and researchers to drive progress in science and industry.

## Contact

Address: 3281 E Guasti Rd

Ontario, CA 91761, United States

Phone: (601) 213-4426

Email: [info@benchchem.com](mailto:info@benchchem.com)

[Contact our Ph.D. Support Team for a compatibility check](#)