

# Application Note: Morpholine-2-carboxamide Scaffolds in Next-Generation Antimalarials

**Author:** BenchChem Technical Support Team. **Date:** May 2026

## Compound of Interest

Compound Name: *Morpholine-2-carboxamide*

CAS No.: 135072-13-8

Cat. No.: B182236

[Get Quote](#)

## Executive Summary & Scientific Rationale

The development of novel antimalarials is driven by the urgent need to overcome resistance to Artemisinin-based Combination Therapies (ACTs). In this context, **Morpholine-2-carboxamide** has emerged as a "privileged scaffold" in medicinal chemistry. Unlike simple morpholine rings used merely for solubility solubilization, the 2-carboxamide derivative introduces a critical chiral center and a vector for hydrogen bonding that is essential for targeting complex enzymatic pockets in *Plasmodium falciparum*.

This guide details the application of **Morpholine-2-carboxamide** as a chiral building block for synthesizing high-potency peptidomimetics targeting the *P. falciparum* 20S proteasome (Pf20S) and Plasmepsins.

## Key Physicochemical Advantages

- **Chirality-Driven Selectivity:** The C2 position of the morpholine ring allows for stereoselective synthesis (

vs.

enantiomers), enabling precise fitting into the S2/S3 pockets of the Pf20S

5 subunit, reducing off-target toxicity against human proteasomes.

- **Metabolic Stability:** The morpholine ether oxygen reduces lipophilicity (lowering LogP) compared to carbocyclic analogs, improving oral bioavailability and reducing metabolic clearance by cytochrome P450s.
- **Hydrogen Bond Networking:** The carboxamide moiety acts as a dual H-bond donor/acceptor, critical for stabilizing the inhibitor-enzyme complex.

## Chemical Synthesis Protocol: Incorporation of the Scaffold

Objective: To couple (2S)-N-Boc-morpholine-2-carboxylic acid to a peptide or heterocyclic amine pharmacophore. This protocol assumes the synthesis of a proteasome inhibitor precursor.

### Materials

- **Scaffold:** (2S)-4-(tert-butoxycarbonyl)morpholine-2-carboxylic acid (CAS: 893332-49-9).
- **Coupling Reagents:** HATU (1-[Bis(dimethylamino)methylene]-1H-1,2,3-triazolo[4,5-b]pyridinium 3-oxid hexafluorophosphate), DIPEA (N,N-Diisopropylethylamine).
- **Solvent:** Anhydrous DMF (Dimethylformamide).
- **Amine Partner:** Variable (e.g., Leucine-derivative or Quinoline amine).

### Step-by-Step Methodology

- **Activation:**
  - Dissolve (2S)-N-Boc-morpholine-2-carboxylic acid (1.0 equiv) in anhydrous DMF (0.1 M concentration) under an inert argon atmosphere.
  - Add DIPEA (3.0 equiv) followed by HATU (1.1 equiv).

- Critical Step: Stir at 0°C for 15 minutes. The color shift to yellow indicates the formation of the active ester.
- Coupling:
  - Add the Amine Partner (1.0 equiv) dropwise to the activated mixture.
  - Allow the reaction to warm to Room Temperature (RT) and stir for 4–6 hours.
  - Validation: Monitor reaction progress via LC-MS. Look for the disappearance of the carboxylic acid mass [M-H]<sup>-</sup> and appearance of the product mass [M+H]<sup>+</sup>.
- Work-up & Purification:
  - Dilute with EtOAc, wash with 5% LiCl (to remove DMF), saturated NaHCO<sub>3</sub>, and brine.
  - Dry over Na<sub>2</sub>SO<sub>4</sub> and concentrate.
  - Purify via Flash Column Chromatography (Hexane:EtOAc gradient).
- Deprotection (Post-Coupling):
  - Treat the intermediate with 20% TFA in DCM (30 min, RT) to remove the N-Boc group, exposing the morpholine nitrogen for further functionalization (e.g., capping with capping groups to tune solubility).

## Visualization: Synthetic Workflow



[Click to download full resolution via product page](#)

Figure 1: Synthetic pathway for incorporating **Morpholine-2-carboxamide** into antimalarial leads.

# Biological Evaluation: SYBR Green I Fluorescence Assay

Objective: To determine the half-maximal inhibitory concentration (

) of the synthesized **Morpholine-2-carboxamide** derivatives against *P. falciparum* (Strain 3D7 or Dd2).

Principle: SYBR Green I intercalates into double-stranded DNA.[1] Since human erythrocytes lack DNA, fluorescence signal is directly proportional to parasite proliferation.

## Reagents & Equipment[2][3]

- Parasite Culture: *P. falciparum* maintained in RPMI 1640 (5% Hematocrit, 2% Parasitemia).
- Lysis Buffer: 20 mM Tris (pH 7.5), 5 mM EDTA, 0.008% saponin, 0.08% Triton X-100.
- Dye: SYBR Green I (10,000x stock).[1]
- Controls: Chloroquine (Positive Control), DMSO (Negative Control, <0.5% final conc).

## Protocol

- Compound Preparation:
  - Prepare 10 mM stock solutions of morpholine derivatives in 100% DMSO.
  - Perform serial 2-fold dilutions in culture medium (RPMI 1640) across a 96-well plate. Ensure final DMSO concentration is <0.5% to prevent solvent toxicity.
- Seeding:
  - Add 100  $\mu$ L of synchronized ring-stage parasite culture (1% parasitemia, 2% hematocrit) to each well containing drugs.
  - Include "No Drug" wells (100% growth) and "Uninfected RBC" wells (Background).
- Incubation:

- Incubate plates at 37°C in a gas chamber (90% N<sub>2</sub>, 5% O<sub>2</sub>, 5% CO<sub>2</sub>) for 72 hours (one complete replication cycle).
- Development:
  - Prepare Lysis/Dye solution: Dilute SYBR Green I (1:5000) into Lysis Buffer.
  - Add 100 µL of Lysis/Dye solution to each well.
  - Incubate in the dark at RT for 1 hour.
- Data Acquisition:
  - Read fluorescence intensity (Excitation: 485 nm, Emission: 535 nm) using a microplate reader.
- Analysis:
  - Subtract background (uninfected RBCs) from all values.
  - Plot Fluorescence vs. Log[Concentration].
  - Calculate  
  
using non-linear regression (Sigmoidal dose-response).

## Visualization: Assay Logic

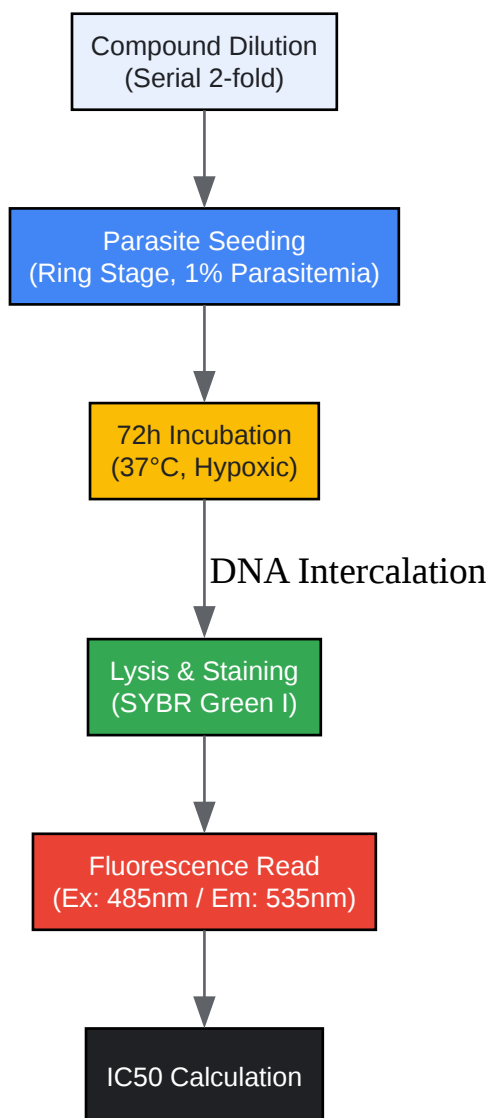

[Click to download full resolution via product page](#)

Figure 2: High-Throughput Screening workflow for phenotypic validation.

## Mechanism of Action: Proteasome Targeting

Recent structural biology studies indicate that morpholine-containing peptidomimetics function as potent inhibitors of the Pf20S proteasome

5 subunit.

- Binding Mode: The morpholine ring (P2 position) occupies the S2 pocket of the enzyme.

- **Selectivity:** The specific chirality of the **Morpholine-2-carboxamide** allows the inhibitor to exploit structural differences between the human constitutive proteasome and the plasmodial proteasome, reducing host toxicity.
- **Resistance:** Proteasome inhibitors are active against artemisinin-resistant strains (Kelch13 mutants) and act on multiple life stages (blood, liver, and gametocyte), making them ideal candidates for transmission-blocking activity.

## Comparative Data: Morpholine Scaffold Efficacy

Compound Class	Target	Scaffold Role	Potency (IC50)	Selectivity Index (SI)
Peptide Boronate	Pf20S (5)	P2-Site Occupancy	< 50 nM	> 100x (vs Human)
Quinoline-Carboxamide	PfEF2 / Kinase	Solubility/Permeability	~ 1 nM	High
HEA-Morpholine	Plasmeprin X	Transition State Mimic	~ 5 $\mu$ M	Moderate

Table 1: Representative efficacy data for morpholine-containing antimalarials derived from recent literature.

## Visualization: Proteasome Inhibition Pathway

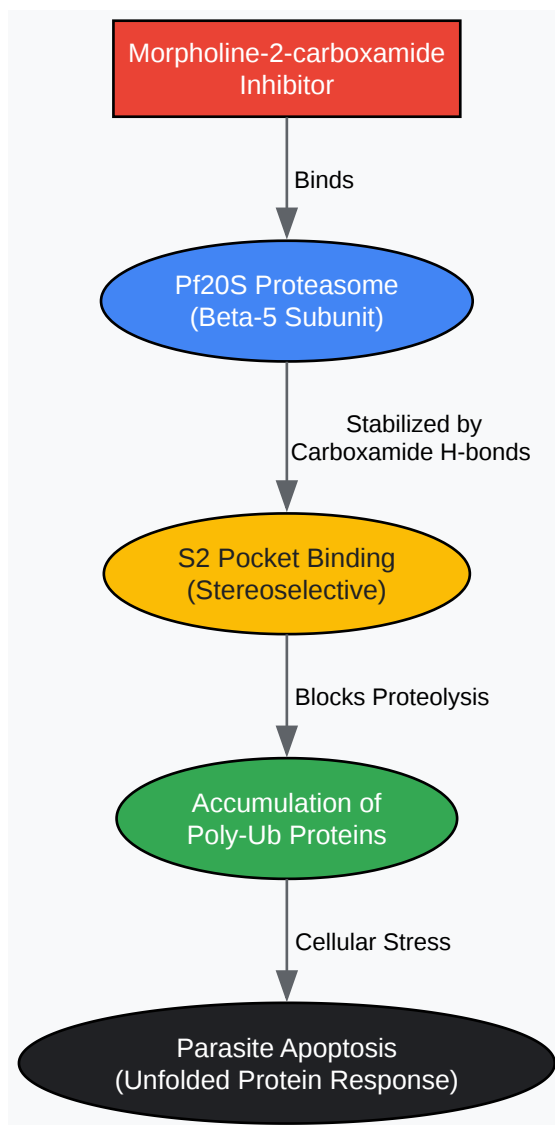

[Click to download full resolution via product page](#)

Figure 3: Mechanism of Action for Morpholine-based Proteasome Inhibitors.

## References

- Development of a highly selective *Plasmodium falciparum* proteasome inhibitor. Source: National Institutes of Health (NIH) / PMC. Context: Describes the structural basis of morpholine-containing inhibitors binding to Pf20S.
- Design of proteasome inhibitors with oral efficacy in vivo against *Plasmodium falciparum*. Source: PubMed. Context: Validates the use of amino-amide boronates (related to carboxamide scaffolds) for oral antimalarial therapy.

- Discovery of a Quinoline-4-carboxamide Derivative (DDD107498). Source: Journal of Medicinal Chemistry (ACS). Context: Highlights a specific morpholine-linked carboxamide with 1 nM potency and excellent pharmacokinetic properties.[2]
- Plasmodium Falciparum: Development and Validation of SYBR Green I Assay. Source: PubMed. Context: The authoritative protocol for the biological assay described in Section 3.
- Morpholine As a Scaffold in Medicinal Chemistry. Source: ChemMedChem (via PubMed). Context: General review of morpholine synthesis and its role in improving drug-like properties (LogP, pKa).

### Need Custom Synthesis?

BenchChem offers custom synthesis for rare earth carbides and specific isotopic labeling.

Email: [info@benchchem.com](mailto:info@benchchem.com) or [Request Quote Online](#).

## Sources

- [1. The SYBR Green I Malaria Drug Sensitivity Assay: Performance in Low Parasitemia Samples - PMC \[pmc.ncbi.nlm.nih.gov\]](#)
- [2. pubs.acs.org \[pubs.acs.org\]](#)
- To cite this document: BenchChem. [Application Note: Morpholine-2-carboxamide Scaffolds in Next-Generation Antimalarials]. BenchChem, [2026]. [Online PDF]. Available at: [\[https://www.benchchem.com/product/b182236/docs#application-note-morpholine-2-carboxamide-scaffolds-in-next-generation-antimalarials\]](https://www.benchchem.com/product/b182236/docs#application-note-morpholine-2-carboxamide-scaffolds-in-next-generation-antimalarials)

---

### Disclaimer & Data Validity:

The information provided in this document is for Research Use Only (RUO) and is strictly not intended for diagnostic or therapeutic procedures. While BenchChem strives to provide accurate protocols, we make no warranties, express or implied, regarding the fitness of this product for every specific experimental setup.

**Technical Support:** The protocols provided are for reference purposes. Unsure if this reagent suits your experiment?

**Need Industrial/Bulk Grade?** [Request Custom Synthesis Quote](#)

## BenchChem

Our mission is to be the trusted global source of essential and advanced chemicals, empowering scientists and researchers to drive progress in science and industry.

### Contact

Address: 3281 E Guasti Rd  
Ontario, CA 91761, United States  
Phone: (601) 213-4426  
Email: [info@benchchem.com](mailto:info@benchchem.com)

[Contact our Ph.D. Support Team for a compatibility check](#)