

# A Researcher's Guide to Cross-Validating Molecular Docking with Experimental Data

**Author:** BenchChem Technical Support Team. **Date:** May 2026

## Compound of Interest

Compound Name: *Ethyl 2-phenylimidazo[1,2-a]pyridine-3-carboxylate*

CAS No.: *119448-82-7*

Cat. No.: *B181992*

[Get Quote](#)

For researchers, scientists, and drug development professionals, this guide provides a comprehensive comparison of molecular docking simulations with established experimental validation techniques. It offers detailed protocols for key experiments, presents quantitative data for comparative analysis, and visualizes critical workflows and pathways to bridge the gap between computational predictions and real-world biological activity.

Molecular docking has emerged as a powerful computational tool in structure-based drug discovery, enabling the rapid screening of large compound libraries and providing insights into potential protein-ligand interactions. However, the predictions generated by docking simulations are theoretical and necessitate rigorous experimental validation to confirm their accuracy and biological relevance. This guide delves into the essential techniques used to cross-validate molecular docking results, ensuring a higher confidence in lead compound identification and optimization.

## Comparing Docking Performance with Experimental Realities

A crucial aspect of validating molecular docking is to compare the predicted binding affinities and poses with experimentally determined values. While a perfect correlation is not always expected due to the inherent simplifications in scoring functions, a good docking protocol should be able to rank active compounds higher than inactive ones and predict binding modes that are consistent with experimental structures.

One of the primary metrics for evaluating the accuracy of a docking pose is the Root Mean Square Deviation (RMSD) between the predicted ligand conformation and the experimentally determined one, typically from X-ray crystallography. An RMSD value of less than 2.0 Å is generally considered a successful prediction.

## Data Presentation: Docking Scores vs. Experimental Binding Affinities

The following tables provide a snapshot of the correlation between docking scores from popular software (AutoDock Vina and GOLD) and experimentally measured binding affinities (IC<sub>50</sub> and pIC<sub>50</sub>) for different protein targets.

Table 1: AutoDock Vina Docking Scores vs. Experimental IC<sub>50</sub> for Monoacylglycerol Lipase (MAGL) Inhibitors[1]

Compound	AutoDock Vina Score (kcal/mol)	Experimental IC <sub>50</sub> (nM)
Pristimerin	-11.5	204 ± 16.2
β-amyrin	-10.7	2800 ± 500
α-amyrin	-8.6	9300 ± 1200

A lower Vina score indicates a more favorable predicted binding affinity. A lower IC<sub>50</sub> value indicates a more potent inhibitor.

Table 2: GOLD Docking Scores (GoldScore) vs. Experimental pIC<sub>50</sub> for Acetylcholinesterase (AChE) Inhibitors[2]

Compound	GoldScore	Experimental pIC50
Galantamine Derivative 1	85.2	7.5
Galantamine Derivative 2	82.1	7.2
Galantamine Derivative 3	78.5	6.8
Galantamine Derivative 4	75.3	6.5
Galantamine Derivative 5	70.1	6.1

A higher GoldScore indicates a more favorable predicted binding affinity. A higher pIC50 value (pIC50 =  $-\log(\text{IC}_{50})$ ) indicates a more potent inhibitor.

## Experimental Protocols for Validation

Accurate experimental validation is the cornerstone of successful structure-based drug design. Below are detailed methodologies for key techniques used to validate molecular docking results.

### Isothermal Titration Calorimetry (ITC)

ITC is a gold-standard biophysical technique that directly measures the heat released or absorbed during a binding event, providing a complete thermodynamic profile of the interaction, including the binding affinity ( $K_d$ ), stoichiometry ( $n$ ), and enthalpy ( $\Delta H$ ) and entropy ( $\Delta S$ ) changes.

Experimental Protocol:

- Sample Preparation:
  - Dialyze both the protein and the ligand against the same buffer to minimize buffer mismatch effects. A common buffer is phosphate-buffered saline (PBS) or HEPES-buffered saline (HBS).
  - Determine the accurate concentrations of the protein and ligand using a reliable method such as UV-Vis spectroscopy or a protein assay.

- The concentration of the ligand in the syringe should be 10-20 times higher than the protein concentration in the sample cell.
- ITC Experiment Setup:
  - Thoroughly clean the sample cell and the injection syringe with the dialysis buffer.
  - Load the protein solution into the sample cell and the ligand solution into the injection syringe.
  - Set the experimental parameters, including the temperature (typically 25°C), stirring speed, and injection volume and duration.
- Data Acquisition and Analysis:
  - Perform a series of injections of the ligand into the protein solution.
  - The instrument measures the heat change associated with each injection.
  - Integrate the heat pulses and plot them against the molar ratio of ligand to protein.
  - Fit the resulting binding isotherm to a suitable binding model (e.g., one-site binding model) to determine the thermodynamic parameters.

## Surface Plasmon Resonance (SPR)

SPR is a label-free optical technique that monitors the binding of a ligand (analyte) to a protein (ligate) immobilized on a sensor chip in real-time. It provides kinetic data, including the association rate constant ( $k_a$ ), dissociation rate constant ( $k_d$ ), and the equilibrium dissociation constant ( $K_d$ ).

Experimental Protocol:

- Sensor Chip Preparation and Ligand Immobilization:
  - Select a sensor chip appropriate for the protein of interest (e.g., a CM5 chip for amine coupling).

- Activate the sensor surface, for example, using a mixture of N-hydroxysuccinimide (NHS) and N-ethyl-N'-(dimethylaminopropyl)carbodiimide (EDC) for amine coupling.
- Inject the protein solution over the activated surface to immobilize it.
- Deactivate any remaining active groups on the surface using ethanolamine.
- Binding Analysis:
  - Prepare a series of dilutions of the ligand in the running buffer.
  - Inject the ligand solutions over the immobilized protein surface, starting from the lowest concentration.
  - Monitor the change in the SPR signal (response units, RU) over time, which reflects the binding of the ligand to the protein.
  - After each injection, allow for a dissociation phase where the running buffer flows over the chip.
- Data Analysis:
  - The resulting sensorgrams are fitted to a kinetic model (e.g., 1:1 Langmuir binding model) to extract the kinetic parameters ( $k_a$  and  $k_d$ ).
  - The equilibrium dissociation constant ( $K_d$ ) is calculated as the ratio of  $k_d$  to  $k_a$ .

## X-ray Crystallography

X-ray crystallography provides high-resolution, three-dimensional structural information of a protein-ligand complex at the atomic level. This "gold standard" technique allows for the direct visualization of the ligand's binding pose, its interactions with the protein's active site, and any conformational changes in the protein upon ligand binding.

Experimental Protocol:

- Protein-Ligand Complex Crystallization:

- Co-crystallization: Incubate the purified protein with a molar excess of the ligand before setting up crystallization trials.
- Soaking: Grow apo-protein crystals first and then soak them in a solution containing the ligand.
- Screen a wide range of crystallization conditions (e.g., different precipitants, pH, and temperature) to obtain well-diffracting crystals of the complex.
- Data Collection:
  - Mount a single crystal and expose it to a high-intensity X-ray beam, typically at a synchrotron source.
  - Collect diffraction data as the crystal is rotated in the X-ray beam.
- Structure Determination and Refinement:
  - Process the diffraction data to obtain a set of structure factors.
  - Solve the phase problem using methods like molecular replacement, using a known structure of the protein as a model.
  - Build an atomic model of the protein-ligand complex into the resulting electron density map.
  - Refine the model to improve its agreement with the experimental data.

## Nuclear Magnetic Resonance (NMR) Spectroscopy

NMR spectroscopy is a powerful technique for studying protein-ligand interactions in solution. It can provide information on the binding interface, binding affinity, and conformational changes of both the protein and the ligand upon complex formation.

Experimental Protocol:

- Sample Preparation:

- For protein-observed NMR, uniformly label the protein with stable isotopes such as  $^{15}\text{N}$  and/or  $^{13}\text{C}$ .
- Prepare a concentrated, stable, and pure sample of the labeled protein in a suitable NMR buffer.
- NMR Titration Experiments:
  - Acquire a reference NMR spectrum of the free protein (e.g., a  $^1\text{H}$ - $^{15}\text{N}$  HSQC spectrum).
  - Titrate the protein sample with increasing concentrations of the unlabeled ligand.
  - Acquire an NMR spectrum at each titration point.
- Data Analysis:
  - Monitor the chemical shift perturbations (CSPs) of the protein's backbone amide signals upon ligand binding.
  - Map the residues with significant CSPs onto the protein structure to identify the binding site.
  - Analyze the titration curves of the CSPs to determine the dissociation constant ( $K_d$ ) of the interaction.

## Mandatory Visualizations

To further clarify the concepts discussed, the following diagrams illustrate key workflows and pathways relevant to molecular docking and its experimental validation.

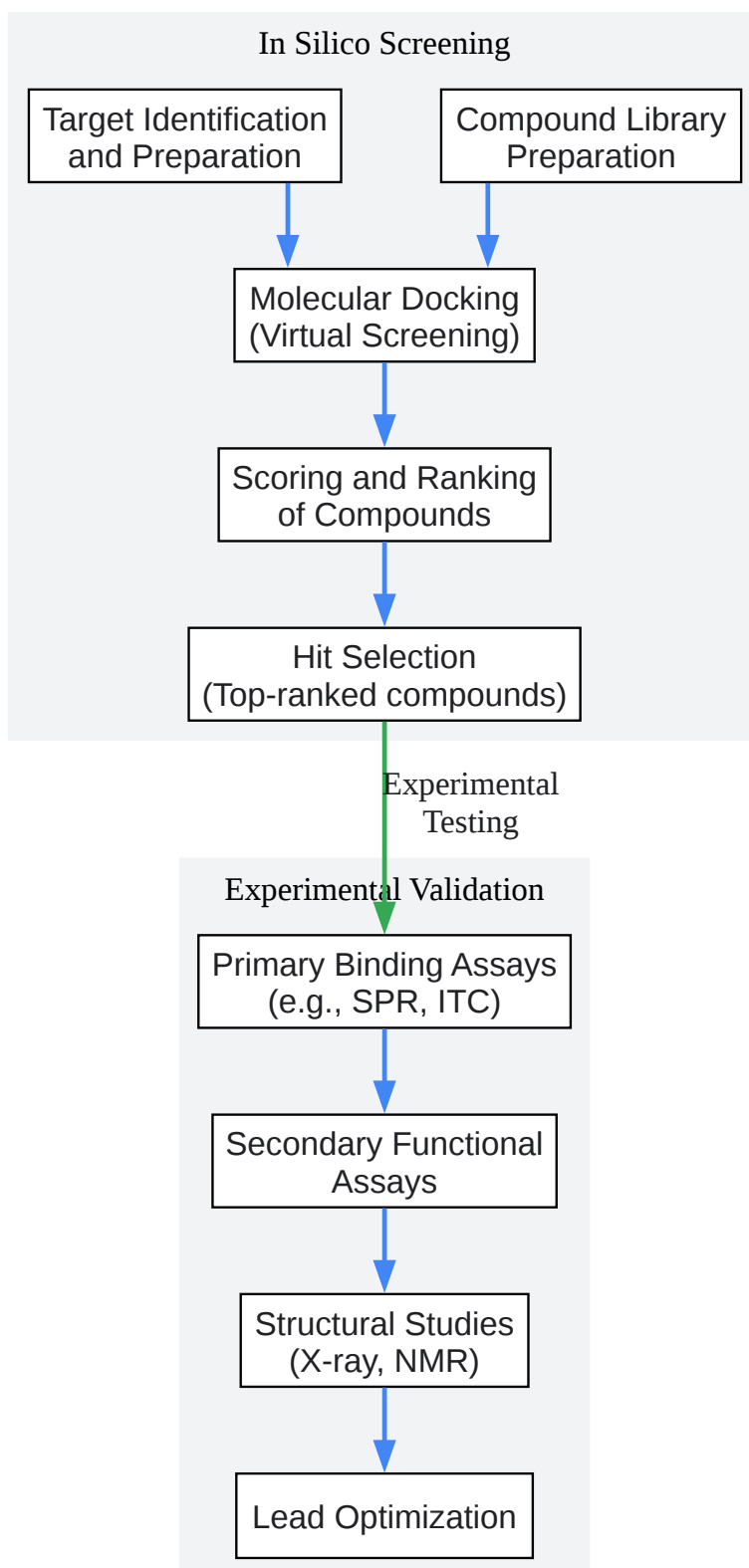

[Click to download full resolution via product page](#)

**Caption:** A typical workflow for virtual screening and experimental validation.

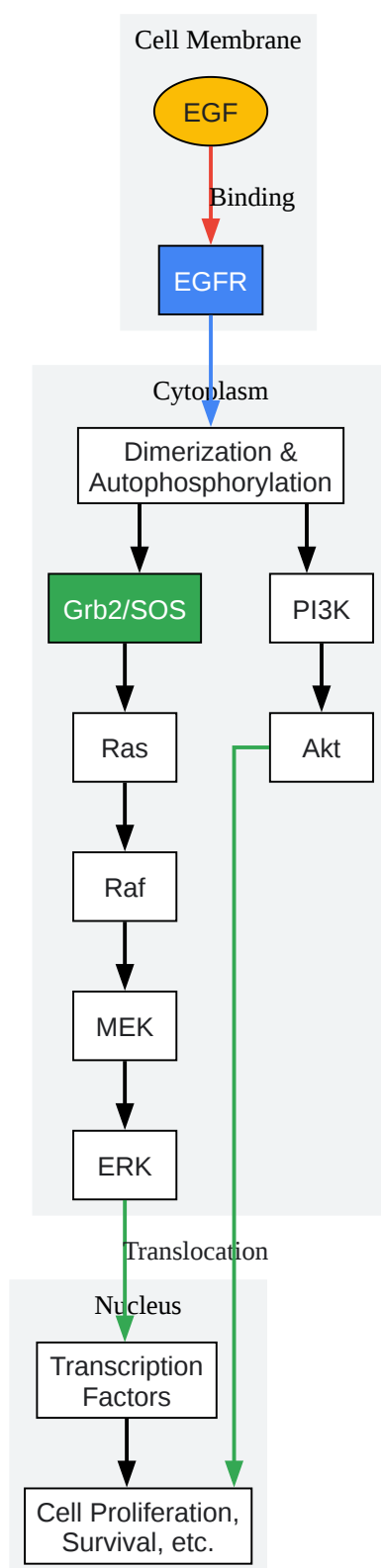

[Click to download full resolution via product page](#)

**Caption:** A simplified diagram of the EGFR signaling pathway, a common drug target.

### Need Custom Synthesis?

BenchChem offers custom synthesis for rare earth carbides and specific isotopic labeling.

Email: [info@benchchem.com](mailto:info@benchchem.com) or [Request Quote Online](#).

## References

- [1. Correlation Between In Silico Docking/Simulation Results and In Vitro MAGL Inhibition Potency of Selected Triterpenes \[mdpi.com\]](#)
- [2. researchgate.net \[researchgate.net\]](#)
- To cite this document: BenchChem. [A Researcher's Guide to Cross-Validating Molecular Docking with Experimental Data]. BenchChem, [2026]. [Online PDF]. Available at: [\[https://www.benchchem.com/product/b181992/docs#a-researcher-s-guide-to-cross-validating-molecular-docking-with-experimental-data\]](https://www.benchchem.com/product/b181992/docs#a-researcher-s-guide-to-cross-validating-molecular-docking-with-experimental-data)

### Disclaimer & Data Validity:

The information provided in this document is for Research Use Only (RUO) and is strictly not intended for diagnostic or therapeutic procedures. While BenchChem strives to provide accurate protocols, we make no warranties, express or implied, regarding the fitness of this product for every specific experimental setup.

**Technical Support:** The protocols provided are for reference purposes. Unsure if this reagent suits your experiment?

**Need Industrial/Bulk Grade?** [Request Custom Synthesis Quote](#)

## BenchChem

Our mission is to be the trusted global source of essential and advanced chemicals, empowering scientists and researchers to drive progress in science and industry.

### Contact

Address: 3281 E Guasti Rd

Ontario, CA 91761, United States

Phone: (601) 213-4426

Email: [info@benchchem.com](mailto:info@benchchem.com)

Contact our Ph.D. Support Team for a compatibility check