

Technical Support Center: Synthesis of 1,4-Disubstituted Phthalazines

Author: BenchChem Technical Support Team. **Date:** May 2026

Compound of Interest

Compound Name: 1-Phthalazinamine

CAS No.: 19064-69-8

Cat. No.: B018529

[Get Quote](#)

This technical support center provides troubleshooting guides and frequently asked questions (FAQs) to assist researchers, scientists, and drug development professionals in overcoming common challenges encountered during the synthesis of 1,4-disubstituted phthalazines.

Troubleshooting Guides

This section is designed to help you troubleshoot common issues that may arise during the synthesis of 1,4-disubstituted phthalazines. The problems are categorized by the synthetic step.

Step 1: Synthesis of Phthalazin-1,4-dione from Phthalic Anhydride

Question: My reaction to form phthalazin-1,4-dione from phthalic anhydride and hydrazine hydrate is giving a low yield. What are the possible causes and solutions?

Answer: Low yields in this step can be attributed to several factors:

- **Incomplete Reaction:** The reaction may not have gone to completion. Monitor the reaction progress using Thin Layer Chromatography (TLC) to ensure all the phthalic anhydride has been consumed.[1] If the reaction is sluggish, you can try increasing the reaction time or temperature. A common starting point is refluxing in ethanol for 4 hours.[2]
- **Suboptimal Temperature:** The reaction temperature might not be optimal. While refluxing in ethanol is common, some procedures use acetic acid at around 120°C for 4-6 hours.[1] Systematically varying the temperature and monitoring the outcome can help you find the ideal conditions for your specific substrate.
- **Product Precipitation:** The product, phthalazin-1,4-dione, should precipitate upon addition of water.[2] If precipitation is incomplete, it could be due to the use of an insufficient amount of water or the product having some solubility in the reaction mixture. Cooling the mixture on an ice bath can aid in complete precipitation.
- **Purification Losses:** Although the crude product is often used directly in the next step, purification by recrystallization can lead to yield loss.[2] If purity is not a major concern for the subsequent step, using the crude product is advisable.

Step 2: Synthesis of 1,4-Dichlorophthalazine

Question: I am getting a low yield and/or impurities during the chlorination of phthalazin-1,4-dione to 1,4-dichlorophthalazine using phosphorus oxychloride (POCl_3). How can I improve this reaction?

Answer: This chlorination step is crucial and can be challenging. Here are some troubleshooting tips:

- **Reagent Quality:** Ensure that the phosphorus oxychloride (POCl_3) is of good quality and has not been exposed to moisture, which can lead to its decomposition.
- **Reaction Conditions:** The reaction is typically performed by refluxing in POCl_3 , sometimes with a catalytic amount of pyridine or 4-dimethylaminopyridine (DMAP).[2] The reaction time is usually between 1 and 3 hours.[2] Prolonged reaction times or excessively high temperatures can lead to the formation of byproducts.

- **Work-up Procedure:** The work-up is critical for obtaining a pure product. The reaction mixture should be cooled and then carefully poured onto crushed ice to quench the excess POCl_3 .^[2] Neutralization with a base like sodium bicarbonate is necessary to precipitate the 1,4-dichlorophthalazine.^[2] Incomplete neutralization will result in a lower yield.
- **Product Instability:** 1,4-Dichlorophthalazine can be sensitive to hydrolysis. Ensure all work-up steps are performed promptly and that the final product is thoroughly dried.
- **Purification:** The crude product can be purified by recrystallization.^[2] However, due to the reactivity of the chloro groups, prolonged heating during recrystallization should be avoided.

Step 3: Nucleophilic Substitution, Suzuki Coupling, and Buchwald-Hartwig Amination

Question: I am having trouble with the nucleophilic substitution of 1,4-dichlorophthalazine with my amine/alkoxide/thiol. What should I consider?

Answer: Challenges in nucleophilic substitution can be overcome by optimizing the following:

- **Reaction Solvent and Temperature:** The choice of solvent is important. Alcohols like isopropanol or butanol are commonly used.^{[2][3]} The reaction temperature may need to be optimized; a typical starting point is 50°C .^[2] For less reactive nucleophiles, a higher temperature may be required.
- **Base:** For acidic nucleophiles like phenols or thiols, the addition of a base such as potassium carbonate (K_2CO_3) or triethylamine (Et_3N) is often necessary to facilitate the reaction.^[3]
- **Mono- versus Di-substitution:** Controlling the stoichiometry of the nucleophile is key to achieving selective mono- or di-substitution. Using 1-2 equivalents of the nucleophile will favor mono-substitution.^[2]

Question: My Suzuki-Miyaura coupling reaction of 1,4-dichlorophthalazine with a boronic acid is not working well. What are common pitfalls?

Answer: Suzuki-Miyaura couplings are powerful but can be sensitive. Here are some common issues and solutions:

- **Catalyst and Ligand Choice:** The choice of palladium catalyst and ligand is critical. A common catalyst is Pd(PPh₃)₄.^[3] The reaction may require screening of different catalysts and ligands to find the optimal combination for your specific substrates.
- **Base Selection:** A base is required to activate the boronic acid.^[4] Inorganic bases like potassium carbonate (K₂CO₃) or cesium carbonate (Cs₂CO₃) are frequently used. The choice of base can significantly impact the reaction outcome.
- **Solvent System:** A mixture of an organic solvent and water (e.g., 1,4-dioxane/water) is often used.^[3] The solvent system must be degassed thoroughly to remove oxygen, which can deactivate the palladium catalyst.
- **Side Reactions:** Homocoupling of the boronic acid and dehalogenation of the starting material are common side reactions.^[5] These can often be minimized by ensuring anaerobic conditions and optimizing the reaction temperature and time.

Question: I am facing difficulties with the Buchwald-Hartwig amination of 1,4-dichlorophthalazine. What are the key parameters to check?

Answer: The Buchwald-Hartwig amination is a versatile method for C-N bond formation but can be challenging.^[6] Consider the following:

- **Catalyst System:** This reaction is highly dependent on the choice of palladium precatalyst and ligand. Different generations of catalysts have been developed to handle a wide range of substrates.^[6] Screening different catalyst/ligand combinations is often necessary.
- **Base:** A strong, non-nucleophilic base is required. Sodium tert-butoxide (NaOtBu) is commonly used. The choice of base can be critical, and some substrates may be sensitive to strong bases.
- **Solvent:** Anhydrous, deoxygenated solvents are essential for the success of this reaction. Toluene and 1,4-dioxane are common choices.
- **Substrate Reactivity:** Aryl chlorides can be less reactive than bromides or iodides in Buchwald-Hartwig amination.^[7] This may necessitate the use of more active catalyst systems or higher reaction temperatures.

Frequently Asked Questions (FAQs)

Q1: What is the most common starting material for the synthesis of 1,4-disubstituted phthalazines?

A1: A common and versatile starting material is phthalic anhydride, which is readily available and can be converted to the phthalazine core in a few steps.[1][2]

Q2: How can I monitor the progress of my reactions?

A2: Thin Layer Chromatography (TLC) is a simple and effective method for monitoring the progress of most of these reactions.[1][2] It allows you to observe the consumption of starting materials and the formation of products. For more quantitative analysis, Liquid Chromatography-Mass Spectrometry (LC-MS) can be used.[3]

Q3: What are some common side reactions to be aware of?

A3: In Suzuki-Miyaura coupling, homocoupling of the boronic acid and dehalogenation of the aryl halide are common side reactions.[5] In Buchwald-Hartwig amination, β -hydride elimination can lead to hydrodehalogenation of the arene.[6] During chlorination with POCl_3 , over-chlorination or decomposition can occur if the reaction is not carefully controlled.

Q4: How can I purify the final 1,4-disubstituted phthalazine products?

A4: Purification is typically achieved by column chromatography on silica gel or by recrystallization from a suitable solvent.[2][3] The choice of method depends on the physical properties of the product and the nature of the impurities.

Q5: Are there alternative synthetic routes to 1,4-disubstituted phthalazines?

A5: Yes, alternative routes exist. One method starts from 2-acetylbenzoic acid, which is then elaborated to the phthalazine core.[8] One-pot, three-component reactions have also been developed for the synthesis of certain phthalazine derivatives.[9]

Data Presentation

Table 1: Summary of Yields for Key Synthetic Steps

Starting Material	Product	Reagents and Conditions	Yield (%)	Reference
Phthalic anhydride	Phthalazin-1,4-dione	Hydrazine monohydrate, Ethanol, Reflux, 4h	83-91%	[2]
Phthalazin-1,4-dione	1,4-Dichlorophthalazine	POCl ₃ , Reflux, 1-3h	~90%	[10]
2-(4-aminobenzoyl)-benzoic acid	4-(4-Aminophenyl)phthalazin-1-(2H)-one	Hydrazine hydrate, Ethanol, Reflux, 6h	50%	[11]
1-(2.37 g) and phthalic anhydride (1.48 g)	2-[4-(4-Oxo-3,4-dihydro-phthalazin-1-yl)-phenyl]-isoindole-1,3-dione	Heat at 250°C for 2h	93%	[11]
2-acetylbenzoic acid (1)	methyl 2-acetylbenzoate (2)	Dimethyl sulfate	77%	[8]
5a/5b	6a/6b	Hydrazine hydrate	90-96%	[8]

Experimental Protocols

Protocol 1: Synthesis of Phthalazin-1,4-dione from Phthalic Anhydride[2]

Materials:

- Phthalic anhydride (1.0 equivalent)

- Hydrazine monohydrate (~40 equivalents)
- Ethanol
- Water

Procedure:

- Dissolve phthalic anhydride in ethanol in a round-bottom flask.
- Add hydrazine monohydrate to the solution.
- Stir the reaction mixture at room temperature or reflux for 4 hours.
- Monitor the reaction by TLC until the phthalic anhydride is consumed.
- Upon completion, add water to the reaction mixture to precipitate the product.
- Filter the precipitate and wash with cold water, followed by a mixture of n-hexane/ethyl acetate (1/2).
- The resulting crude phthalazin-1,4-dione can be used in the next step without further purification.

Protocol 2: Synthesis of 1,4-Dichlorophthalazine from Phthalazin-1,4-dione[2]

Materials:

- Phthalazin-1,4-dione (1 equivalent)
- Phosphorus oxychloride (POCl_3)
- Pyridine (optional, as catalyst)
- Acetonitrile (solvent)
- 4-dimethylaminopyridine (DMAP) or 1,8-Diazabicyclo[5.4.0]undec-7-ene (DBU) (catalyst)

Procedure:

- To a suspension of phthalazin-1,4-dione in acetonitrile, add a catalytic amount of DMAP or DBU.
- Add POCl₃ dropwise to the mixture.
- Heat the reaction mixture to reflux and stir for 1-3 hours.
- After cooling to room temperature, carefully pour the reaction mixture onto crushed ice.
- Neutralize the mixture with a suitable base (e.g., saturated sodium bicarbonate solution) until a precipitate forms.
- Filter the solid, wash with water, and dry to afford 1,4-dichlorophthalazine.
- The crude product can be purified by recrystallization.

Protocol 3: General Procedure for Nucleophilic Substitution of 1,4-Dichlorophthalazine[2]

Materials:

- 1,4-Dichlorophthalazine (1 equivalent)
- Substituted amine (1-2 equivalents)
- Isopropanol or other suitable solvent

Procedure:

- Dissolve 1,4-dichlorophthalazine and the desired amine in isopropanol.
- Heat the reaction mixture to 50°C for 3 hours.
- Monitor the reaction progress by TLC.
- Upon completion, concentrate the mixture in vacuo.

- The crude product can be purified by column chromatography or recrystallization.

Visualizations

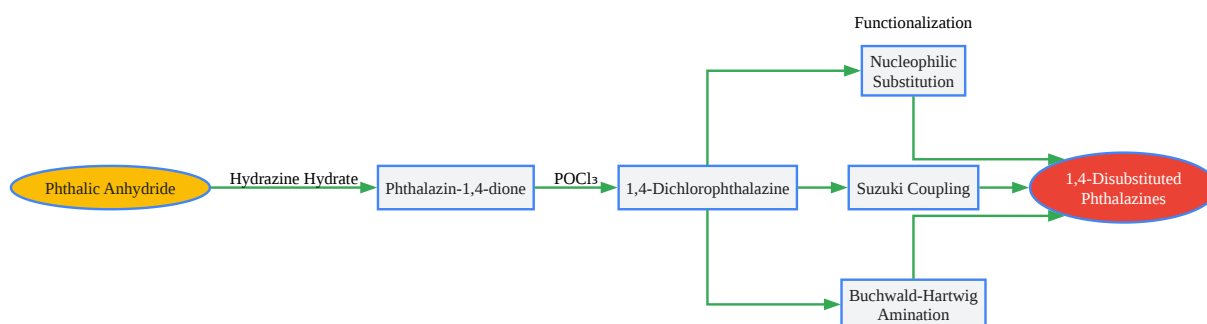

[Click to download full resolution via product page](#)

Caption: General workflow for the synthesis of 1,4-disubstituted phthalazines.

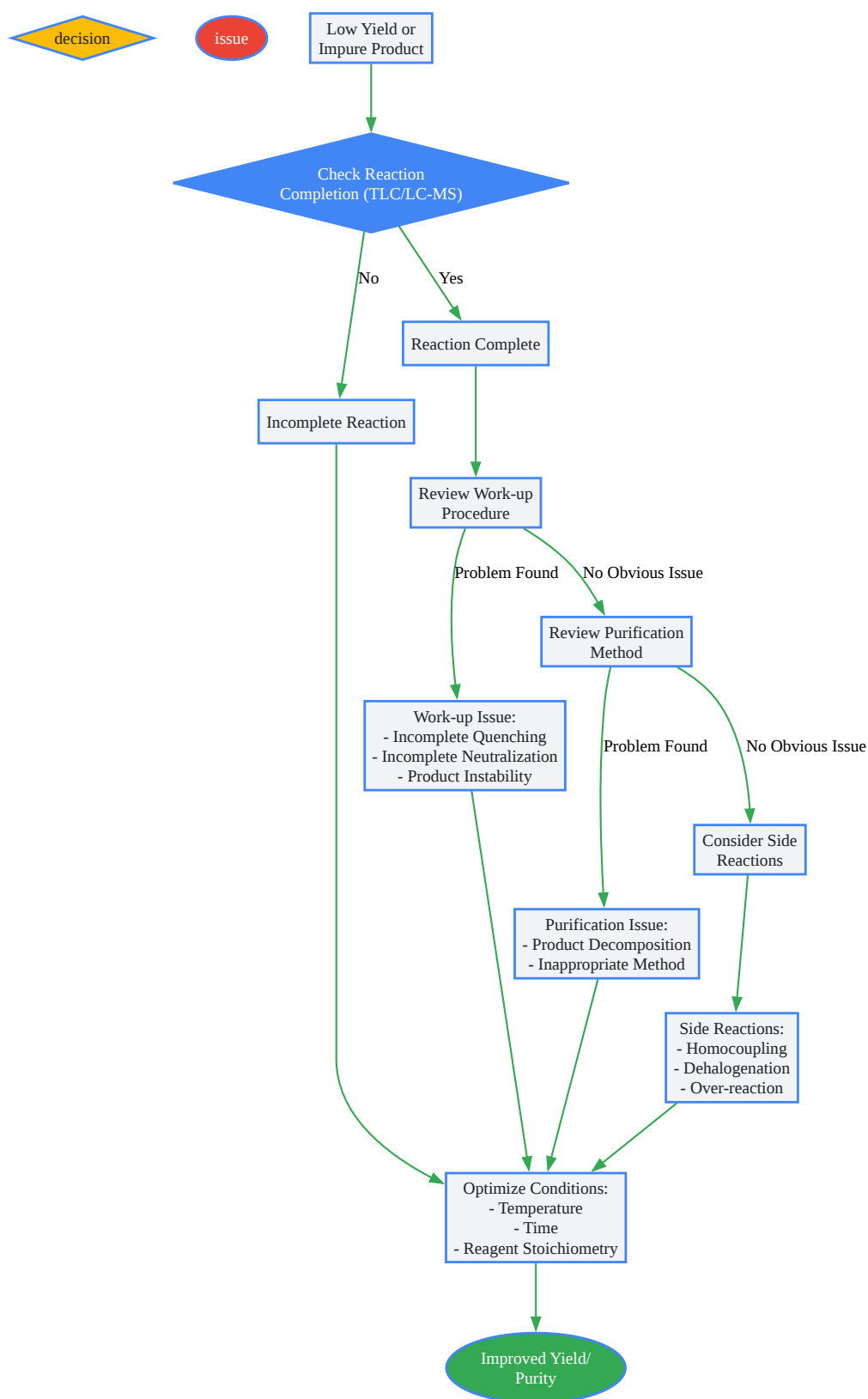

[Click to download full resolution via product page](#)

Caption: A decision-making workflow for troubleshooting synthesis challenges.

Need Custom Synthesis?

BenchChem offers custom synthesis for rare earth carbides and specific isotopic labeling.

Email: info@benchchem.com or [Request Quote Online](#).

References

- [1. benchchem.com \[benchchem.com\]](#)
- [2. benchchem.com \[benchchem.com\]](#)
- [3. benchchem.com \[benchchem.com\]](#)
- [4. Suzuki Coupling \[organic-chemistry.org\]](#)
- [5. Yoneda Labs \[yonedalabs.com\]](#)
- [6. Buchwald–Hartwig amination - Wikipedia \[en.wikipedia.org\]](#)
- [7. reddit.com \[reddit.com\]](#)
- [8. Synthesis and Anticancer Activities of Novel 1,4-Disubstituted Phthalazines - PMC \[pmc.ncbi.nlm.nih.gov\]](#)
- [9. researchgate.net \[researchgate.net\]](#)
- [10. Structural Identification between Phthalazine-1,4-Diones and N-Aminophthalimides via Vilsmeier Reaction: Nitrogen Cyclization and Tautomerization Study - PMC \[pmc.ncbi.nlm.nih.gov\]](#)
- [11. fsc.stafpu.bu.edu.eg \[fsc.stafpu.bu.edu.eg\]](#)
- To cite this document: BenchChem. [Technical Support Center: Synthesis of 1,4-Disubstituted Phthalazines]. BenchChem, [2026]. [Online PDF]. Available at: [\[https://www.benchchem.com/product/b018529/docs#technical-support-center-synthesis-of-1-4-disubstituted-phthalazines\]](https://www.benchchem.com/product/b018529/docs#technical-support-center-synthesis-of-1-4-disubstituted-phthalazines)

Disclaimer & Data Validity:

The information provided in this document is for Research Use Only (RUO) and is strictly not intended for diagnostic or therapeutic procedures. While BenchChem strives to provide accurate protocols, we make no warranties, express or implied, regarding the fitness of this product for every specific experimental setup.

Technical Support: The protocols provided are for reference purposes. Unsure if this reagent suits your experiment?

Need Industrial/Bulk Grade? [Request Custom Synthesis Quote](#)

BenchChem

Our mission is to be the trusted global source of essential and advanced chemicals, empowering scientists and researchers to drive progress in science and industry.

Contact

Address: 3281 E Guasti Rd
Ontario, CA 91761, United States
Phone: (601) 213-4426
Email: info@benchchem.com

[Contact our Ph.D. Support Team for a compatibility check](#)