

Application Notes and Protocols: BODIPY FL-X in FRET-Based Assays

Author: BenchChem Technical Support Team. **Date:** April 2026

Compound of Interest

Compound Name: BODIPY FL-X

CAS No.: 217190-09-5

Cat. No.: B018997

[Get Quote](#)

For Researchers, Scientists, and Drug Development Professionals

Introduction

BODIPY FL-X is a bright, green-fluorescent dye renowned for its exceptional photophysical properties, making it a versatile tool in various fluorescence-based applications.^{[1][2][3]} Its high fluorescence quantum yield, relative insensitivity to pH and solvent polarity, and narrow emission bandwidth make it an ideal fluorophore for Förster Resonance Energy Transfer (FRET)-based assays.^{[1][2][4][5]} This document provides detailed application notes and protocols for utilizing **BODIPY FL-X** in FRET-based assays, particularly in the context of drug discovery and the study of molecular interactions.

BODIPY FL-X possesses an excitation maximum at approximately 504 nm and an emission maximum at around 510 nm.^{[1][6]} The succinimidyl ester (SE) derivative of **BODIPY FL-X** allows for convenient and efficient labeling of primary amines on proteins and other biomolecules.^{[1][4][6]} The "X" in its name refers to a seven-atom aminohexanoyl spacer that separates the fluorophore from the reactive group, which helps to minimize interactions between the dye and the labeled biomolecule.

Key Applications in FRET-Based Assays

BODIPY FL-X is extensively used as an acceptor fluorophore in Time-Resolved FRET (TR-FRET) assays, often paired with a long-lifetime terbium (Tb) chelate as the donor. This combination is particularly advantageous for high-throughput screening (HTS) due to the reduction of background fluorescence and light scattering, which enhances assay sensitivity and robustness.[7]

Protein-Ligand Binding Assays

TR-FRET assays employing **BODIPY FL-X** are powerful tools for quantifying the binding affinity of small molecules to target proteins. This approach has been successfully applied to study inhibitors of various E3 ligases and nuclear receptors, which are critical targets in drug discovery.

a) von Hippel-Lindau (VHL) E3 Ligase:

A highly sensitive TR-FRET assay has been developed to identify and characterize VHL ligands using a BODIPY FL-labeled VHL ligand (BODIPY FL VH032).[8][9] In this assay, a terbium-labeled anti-GST antibody serves as the donor, binding to a GST-tagged VCB (VHL-Elongin C-Elongin B) protein complex. The binding of BODIPY FL VH032 to VHL brings the donor and acceptor into close proximity, resulting in a FRET signal.[8] Competing ligands displace the fluorescent probe, leading to a decrease in the FRET signal.[8]

b) Cereblon (CRBN) E3 Ligase:

Similarly, a BODIPY FL-labeled thalidomide probe has been developed for a highly sensitive TR-FRET assay to characterize cereblon ligands.[5][10][11] This assay demonstrates significantly higher sensitivity compared to previously reported methods, enabling the accurate determination of ligand binding affinities.[5][10]

c) Pregnane X Receptor (PXR):

A TR-FRET assay using BODIPY FL-vindoline as a fluorescent probe has been established for the high-throughput screening of PXR ligands.[6] This assay exhibits a high signal-to-background ratio and excellent stability, making it suitable for identifying novel PXR modulators.[6]

FRET-Based Biosensors

BODIPY FL can be incorporated into genetically encoded or synthetic biosensors to monitor the spatiotemporal dynamics of intracellular signaling molecules. For instance, FRET-based biosensors for cyclic GMP (cGMP) have been developed by flanking a cGMP-binding domain with a FRET pair, which can include BODIPY FL, to detect low nanomolar concentrations of cGMP in living cells.

Quantitative Data

The following tables summarize the quantitative data from the aforementioned TR-FRET assays.

Table 1: Photophysical Properties of BODIPY FL

Property	Value	Reference
Excitation Maximum (λ_{ex})	~504 nm	[1][6]
Emission Maximum (λ_{em})	~510 nm	[1][6]
Fluorescence Lifetime	~5 nanoseconds	[2][5]
Förster Distance (R_0) with BODIPY FL (homo-FRET)	57 Å	[12]

Table 2: Quantitative Data for VHL TR-FRET Assay

Parameter	Value	Conditions	Reference
Kd (BODIPY FL VH032)	3.01 nM	2 nM GST-VCB, 2 nM Tb-anti-GST	[8]
Average IC50 (VH298)	44.31 nM	4 nM BODIPY FL VH032, 2 nM GST-VCB, 2 nM Tb-anti-GST	[1]
Z'-factor	> 0.85	30 to 240 min incubation	[8]

Table 3: Quantitative Data for Cereblon TR-FRET Assay

Parameter	Value	Conditions	Reference
Kd (BODIPY FL Thalidomide)	3.6 nM	2 nM His-cereblon, 2 nM Tb-anti-His	[5][10]
IC50 (Pomalidomide)	6.4 nM	4 nM BODIPY FL Thalidomide, 2 nM His-cereblon, 2 nM Tb-anti-His	[10]
Assay Sensitivity Improvement	41- to 187-fold	Compared to previous FP and TR-FRET assays	[10]

Table 4: Quantitative Data for PXR TR-FRET Assay

Parameter	Value	Conditions	Reference
Kd (BODIPY FL vindoline)	256 nM	5 nM GST-hPXR-LBD, 5 nM Tb-anti-GST	[6]
IC50 (Rifampicin)	27.2 μ M	100 nM BODIPY FL vindoline, 5 nM GST-hPXR-LBD, 5 nM Tb-anti-GST	[6]
Signal-to-Background Ratio	> 7-fold	100 nM BODIPY FL vindoline	[6]

Experimental Protocols

General Protocol for Protein Labeling with BODIPY FL-X, SE

This protocol describes the general procedure for labeling a protein with **BODIPY FL-X, Succinimidyl Ester**.

Materials:

- **BODIPY FL-X, SE** (dissolved in anhydrous DMSO or DMF)
- Protein to be labeled (in amine-free buffer, e.g., PBS pH 7.4)
- Reaction buffer: 0.1 M sodium bicarbonate, pH 8.3
- Purification column (e.g., Sephadex G-25)

Procedure:

- Dissolve the protein in the reaction buffer at a suitable concentration (e.g., 1-10 mg/mL).
- Prepare a stock solution of **BODIPY FL-X, SE** in anhydrous DMSO or DMF.
- Add the reactive dye solution to the protein solution while gently stirring. The molar ratio of dye to protein may need to be optimized, but a starting point of 10-20 fold molar excess of dye is common.
- Incubate the reaction at room temperature for 1 hour, protected from light.
- Separate the labeled protein from the unreacted dye using a size-exclusion chromatography column.
- Determine the degree of labeling (DOL) by measuring the absorbance of the protein (at 280 nm) and the BODIPY FL dye (at ~504 nm).

Protocol for VHL TR-FRET Competitive Binding Assay

This protocol is adapted from the assay developed for characterizing VHL ligands.[8]

Materials:

- Assay Buffer: 50 mM Tris (pH 7.5), 0.01% Triton X-100
- GST-VCB protein complex
- Tb-anti-GST antibody

- BODIPY FL VH032 probe
- Test compounds dissolved in DMSO
- 384-well low-volume black assay plates

Procedure:

- Prepare solutions of GST-VCB (4 nM), Tb-anti-GST antibody (4 nM), and BODIPY FL VH032 (8 nM) in assay buffer.
- Dispense test compounds or DMSO (for controls) into the assay plate using an acoustic liquid handler or multichannel pipette.
- Add 10 μ L of a pre-mixed solution of GST-VCB and Tb-anti-GST antibody to each well.
- Incubate for 30 minutes at room temperature.
- Add 10 μ L of the BODIPY FL VH032 solution to each well. Final concentrations should be 2 nM GST-VCB, 2 nM Tb-anti-GST, and 4 nM BODIPY FL VH032.
- Incubate for 90 minutes at room temperature, protected from light.
- Read the plate on a TR-FRET compatible plate reader. Excite at \sim 340 nm and measure emission at 490 nm (Tb donor) and 520 nm (BODIPY FL acceptor).
- Calculate the TR-FRET ratio (520 nm emission / 490 nm emission) and plot the data against the concentration of the test compound to determine the IC50 value.

Visualizations

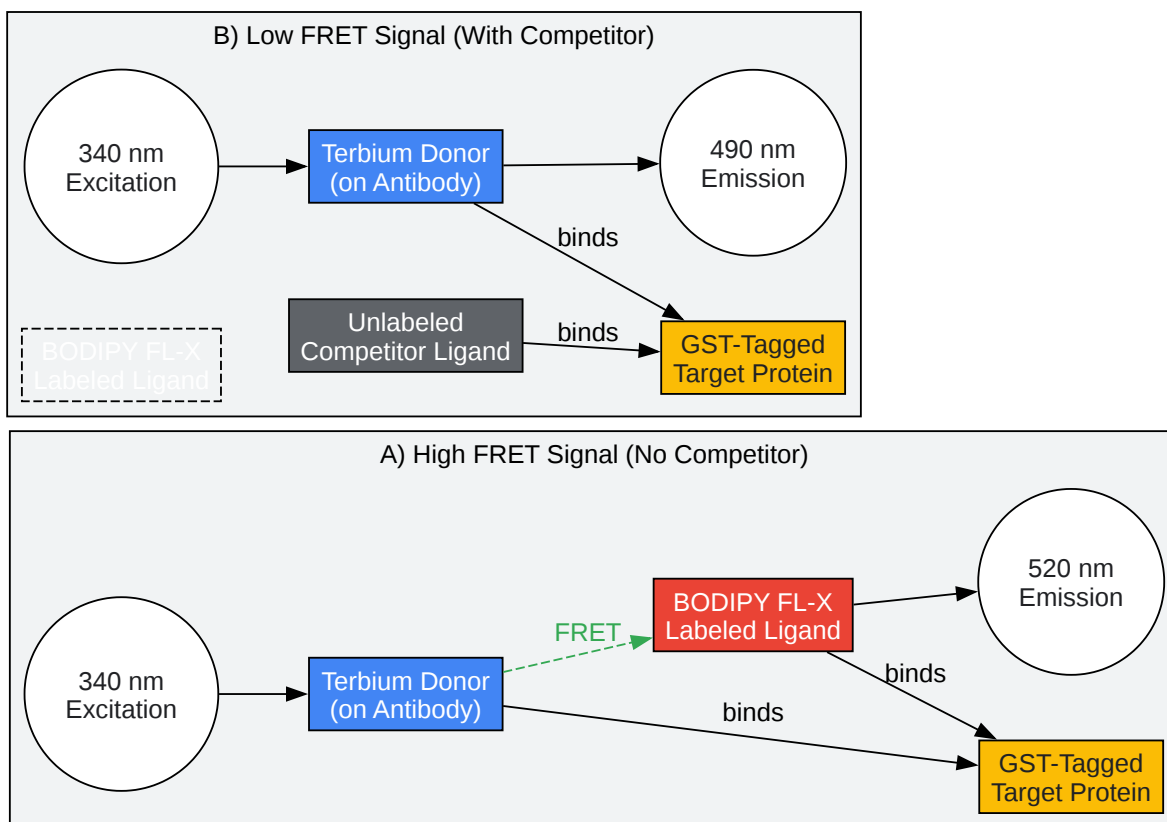

[Click to download full resolution via product page](#)

Caption: Principle of a competitive TR-FRET binding assay using **BODIPY FL-X**.

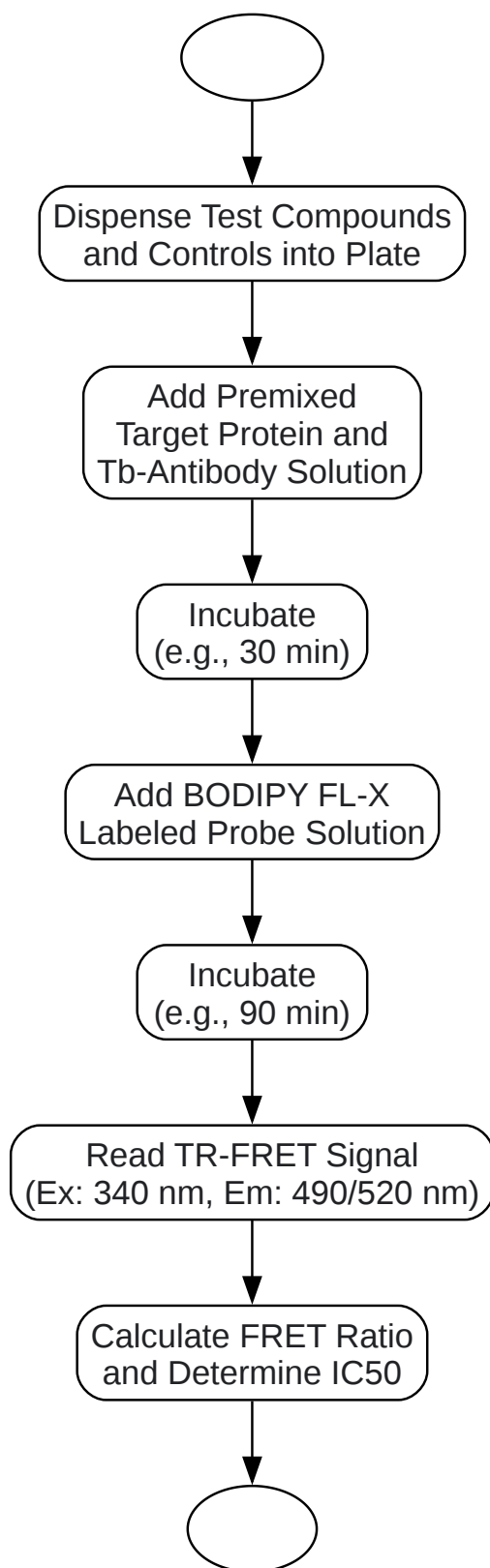

[Click to download full resolution via product page](#)

Caption: General experimental workflow for a **BODIPY FL-X** based TR-FRET assay.

Conclusion

BODIPY FL-X is a robust and versatile fluorescent probe for FRET-based assays. Its favorable photophysical characteristics, coupled with the sensitivity of TR-FRET, make it an invaluable tool for academic research and high-throughput drug discovery. The provided protocols and data serve as a comprehensive guide for researchers looking to implement **BODIPY FL-X** in their studies of molecular interactions and cellular signaling.

Need Custom Synthesis?

BenchChem offers custom synthesis for rare earth carbides and specific isotopic labeling.

Email: info@benchchem.com or [Request Quote Online](#).

References

- [1. pubs.acs.org \[pubs.acs.org\]](https://pubs.acs.org)
- [2. BODIPY FL Dye | Thermo Fisher Scientific - US \[thermofisher.com\]](https://thermofisher.com)
- [3. medchemexpress.com \[medchemexpress.com\]](https://medchemexpress.com)
- [4. Development of BODIPY FL Thalidomide As a High-Affinity Fluorescent Probe for Cereblon in a Time-Resolved Fluorescence Resonance Energy Transfer Assay. | Semantic Scholar \[semanticscholar.org\]](#)
- [5. Development of BODIPY FL Thalidomide as a High-Affinity Fluorescent Probe for Cereblon in a Time-Resolved Fluorescence Resonance Energy Transfer Assay - PMC \[pmc.ncbi.nlm.nih.gov\]](https://pubmed.ncbi.nlm.nih.gov)
- [6. pubs.acs.org \[pubs.acs.org\]](https://pubs.acs.org)
- [7. documents.thermofisher.com \[documents.thermofisher.com\]](https://documents.thermofisher.com)
- [8. Development of BODIPY FL VH032 as a High-Affinity and Selective von Hippel–Lindau E3 Ligase Fluorescent Probe and Its Application in a Time-Resolved Fluorescence Resonance Energy-Transfer Assay - PMC \[pmc.ncbi.nlm.nih.gov\]](https://pubmed.ncbi.nlm.nih.gov)
- [9. pubs.acs.org \[pubs.acs.org\]](https://pubs.acs.org)
- [10. pubs.acs.org \[pubs.acs.org\]](https://pubs.acs.org)
- [11. researchgate.net \[researchgate.net\]](https://researchgate.net)

- [12. Fluorescence Resonance Energy Transfer FRET—Note 1.2 | Thermo Fisher Scientific - SG \[thermofisher.com\]](#)
- To cite this document: BenchChem. [Application Notes and Protocols: BODIPY FL-X in FRET-Based Assays]. BenchChem, [2026]. [Online PDF]. Available at: [<https://www.benchchem.com/product/b018997/docs#application-notes-and-protocols-bodipy-fl-x-in-fret-based-assays>]

Disclaimer & Data Validity:

The information provided in this document is for Research Use Only (RUO) and is strictly not intended for diagnostic or therapeutic procedures. While BenchChem strives to provide accurate protocols, we make no warranties, express or implied, regarding the fitness of this product for every specific experimental setup.

Technical Support: The protocols provided are for reference purposes. Unsure if this reagent suits your experiment?

Need Industrial/Bulk Grade? [Request Custom Synthesis Quote](#)

BenchChem

Our mission is to be the trusted global source of essential and advanced chemicals, empowering scientists and researchers to drive progress in science and industry.

Contact

Address: 3281 E Guasti Rd
Ontario, CA 91761, United States
Phone: (601) 213-4426
Email: info@benchchem.com

[Contact our Ph.D. Support Team for a compatibility check](#)