

# Structure-activity relationship of Boc-protected 2-ethynylaniline derivatives

**Author:** BenchChem Technical Support Team. **Date:** May 2026

## Compound of Interest

**Compound Name:** *Tert-butyl (2-ethynylphenyl)carbamate*

**CAS No.:** *199454-06-3*

**Cat. No.:** *B177329*

[Get Quote](#)

## Chemo-Functional Profiling of Boc-Protected 2-Ethynylanilines

From Synthetic Reactivity to Bioactive Scaffolds

### Executive Summary: The Privileged Intermediate

In the architecture of modern drug discovery, Boc-protected 2-ethynylaniline (N-Boc-2-alkynylaniline) is not merely a transient intermediate; it is a "privileged switch." Its structural rigidity, combined with the latent reactivity of the alkyne "warhead" and the protected amine, makes it a critical junction point for accessing nitrogen-containing heterocycles—specifically indoles, quinolines, and azepinoindoles.

This technical guide dissects the Structure-Reactivity Relationships (SRR) of this scaffold. Unlike traditional biological SAR, which correlates structure to receptor binding, the "activity" of this intermediate is defined by its chemoselectivity and cyclization efficiency under transition-

metal catalysis. Understanding these parameters is essential for high-throughput synthesis of kinase inhibitor libraries (e.g., EGFR, c-Met).

## Chemical Space & Synthesis: The Sonogashira Gateway

The entry point to this scaffold is almost exclusively through Sonogashira cross-coupling. The Boc group plays a dual role here: it protects the amine from oxidation and prevents the "poisoning" of palladium catalysts by the free nitrogen lone pair.

### Mechanistic Causality in Synthesis

- **The Boc Effect:** Free 2-ethynylanilines are prone to oxidative dimerization (Glaser coupling) or polymerization. The tert-butyloxycarbonyl (Boc) group provides steric bulk and withdraws electron density from the nitrogen, reducing its nucleophilicity and stabilizing the monomer.
- **Catalytic nuances:** While Pd(PPh<sub>3</sub>)<sub>2</sub>Cl<sub>2</sub> is standard, bulky phosphine ligands (e.g., XPhos) are required for sterically hindered ortho-substituted substrates to facilitate the oxidative addition step.

### Validated Synthetic Protocol (Standard)

Objective: Synthesis of tert-butyl (2-(phenylethynyl)phenyl)carbamate.

- **Reagents:** 2-Iodo-N-Boc-aniline (1.0 equiv), Phenylacetylene (1.2 equiv), Pd(PPh<sub>3</sub>)<sub>2</sub>Cl<sub>2</sub> (2 mol%), CuI (1 mol%), Et<sub>3</sub>N (3.0 equiv).
- **Solvent:** Anhydrous THF or DMF (degassed).
- **Conditions:** Stir at RT for 4-12 h under N<sub>2</sub> atmosphere.
- **Workup:** Filter off ammonium salts, concentrate, and purify via silica flash chromatography (Hexane/EtOAc).
- **Validation:** Disappearance of aryl iodide (TLC); Appearance of internal alkyne stretch (~2220 cm<sup>-1</sup>) in IR.

## Structure-Reactivity Relationship (SRR) Analysis

The core utility of Boc-2-ethynylanilines lies in their divergent cyclization pathways. The "Activity" in this context is the Cyclization Efficiency (CE).

### Electronic Effects (Hammett Correlation)

The electronic nature of the substituent on the alkyne terminus (

) and the aniline ring (

) dictates the reaction pathway.

Substituent ( )	Electronic Effect	Impact on Cyclization (Au/Cu Catalysis)	Mechanism Shift
Electron-Donating (e.g., -OMe)	Increases Nucleophilicity	Accelerates 5-endo-dig cyclization.	Stabilizes the cationic intermediate, lowering activation energy.
Electron-Withdrawing (e.g., -CF <sub>3</sub> )	Decreases Nucleophilicity	Decelerates cyclization; requires higher temp or stronger Lewis Acid.	May promote 6-endo-dig over 5-endo-dig depending on catalyst.
Boc Group (vs. Free NH)	Electron-Withdrawing	Directs Regioselectivity. Prevents N-lone pair interference; promotes specific metal-activation of alkyne.	Essential for Gold (Au) catalysis to prevent catalyst sequestration.

### Catalyst-Dependent Divergence

The choice of metal catalyst determines whether the Boc-protected intermediate yields an Indole (5-membered) or a Quinoline/Isoquinoline (6-membered).

- Gold (AuCl, Au(PPh<sub>3</sub>)Cl): Acts as a soft Lewis acid, activating the alkyne

-system. The Boc-nitrogen attacks the activated alkyne (5-endo-dig or 5-exo-dig), followed by Boc-migration or elimination.

- Copper (CuI): Often requires higher temperatures; frequently leads to 2-substituted indoles via a tandem coupling-cyclization mechanism.
- Base-Mediated (t-BuOK): Can force cyclization via a nucleophilic mechanism, often requiring harsh conditions if the Boc group is retained.

## Visualization: The Reactivity Decision Tree

The following diagram illustrates the divergent pathways available to the Boc-2-ethynylaniline scaffold based on reaction conditions and structural inputs.

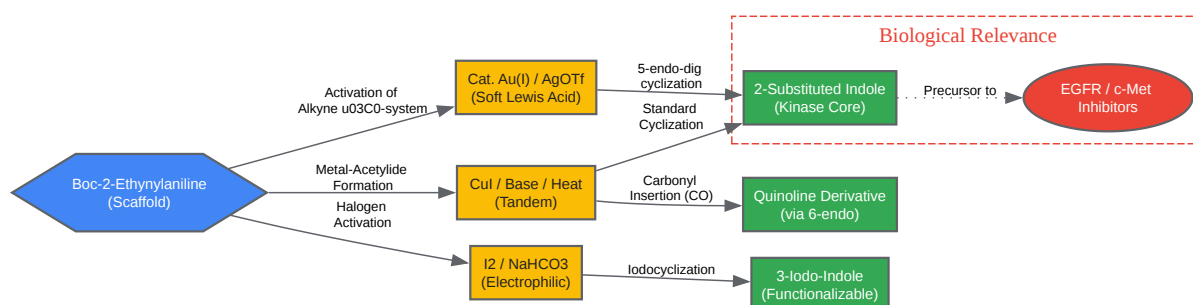

[Click to download full resolution via product page](#)

Figure 1: Divergent reactivity map of Boc-2-ethynylanilines. Catalyst selection steers the scaffold toward specific bioactive heterocycles.

## Biological Implications: The "Activity" in SAR

While the Boc-protected form is an intermediate, its "Activity" is retrospectively defined by the potency of the final drug molecule.

### Kinase Inhibition (EGFR & c-Met)

Derivatives synthesized from this scaffold are prominent in the development of Tyrosine Kinase Inhibitors (TKIs).

- Mechanism: The indole/quinoline core mimics the adenine ring of ATP, binding to the kinase hinge region.
- SAR Insight: The substituent (originally the alkyne terminus) often projects into the hydrophobic pocket of the enzyme. Large aromatic groups (Phenyl, Pyridyl) at this position—introduced via the initial Sonogashira coupling—are crucial for nanomolar potency against targets like c-Met and Mer kinase.

## Metabolic Stability

- Boc as a Prodrug Feature: In rare cases, the Boc group acts to increase lipophilicity (LogP) for cell membrane penetration, intended to be cleaved metabolically (or via acidic microenvironment in tumors) to release the active free-amine pharmacophore.

## Detailed Experimental Protocol: Gold-Catalyzed Cyclization

This protocol describes the conversion of a Boc-2-ethynylaniline to a 2-substituted indole, a key workflow for generating library compounds.

System: AuCl(PPh<sub>3</sub>) / AgOTf catalyzed cyclization.

- Preparation: In a flame-dried vial, dissolve Boc-2-(phenylethynyl)aniline (0.5 mmol) in anhydrous Toluene (2.0 mL).
- Catalyst Addition: Add AuCl(PPh<sub>3</sub>) (5 mol%) and AgOTf (5 mol%) sequentially. Note: The silver salt activates the gold precatalyst by precipitating AgCl.
- Reaction: Stir at 80°C for 2-4 hours. Monitor by TLC (Hexane/EtOAc 8:1). The Boc group may be cleaved in situ or retained depending on exact conditions; often, N-Boc indole is the primary product.
- Quench: Filter through a short pad of Celite to remove metal residues.

- Purification: Concentrate and purify via flash chromatography.
- Data Check:
  - <sup>1</sup>H NMR: Look for the characteristic indole C3-H singlet (~6.5-7.0 ppm) if C3 is unsubstituted.
  - Yield Expectations: Electron-rich alkynes: >85%; Electron-poor alkynes: 60-75%.

## References

- Sonogashira Coupling Reviews
  - Chinchilla, R., & Nájera, C. (2007). The Sonogashira Reaction: A Booming Methodology in Synthetic Organic Chemistry. *Chemical Reviews*, 107(3), 874–922. [Link](#)
- Indole Synthesis via Gold Catalysis
  - Li, Y., & Wang, J. (2006). Gold-Catalyzed Cyclization of 2-Alkynylanilines to Indoles. *Journal of Organic Chemistry*, 71(20), 4951-4955. [Link](#)
- Mechanism of Cyclization (5-endo-dig)
  - Fukuda, Y., Utimoto, K., & Nozaki, H. (1991). Preparation of 2,3-disubstituted indoles from 2-alkynylanilines.[1][2][3] *Heterocycles*, 32, 2291.
- Biological Application (Kinase Inhibitors)
  - Zhang, Y., et al. (2024).[4] Design, Synthesis, and Biological Evaluation of 2-Substituted Aniline Pyrimidine Derivatives as Potent Dual Mer/c-Met Inhibitors. *International Journal of Molecular Sciences*. [Link](#)
- Ruthenium Catalysis & Rearrangements: Trost, B. M., & McClory, A. (2008). Ruthenium-catalyzed cycloisomerization of alkynylanilines. *Chemistry – An Asian Journal*, 3(1), 164-194.

### Need Custom Synthesis?

BenchChem offers custom synthesis for rare earth carbides and specific isotopic labeling.

Email: [info@benchchem.com](mailto:info@benchchem.com) or [Request Quote Online](#).

## Sources

- 1. Gold/Copper-Co-catalyzed Tandem Reactions of 2-Alkynylanilines: A Synthetic Strategy for the C2-Quaternary Indolin-3-ones - PubMed [pubmed.ncbi.nlm.nih.gov]
- 2. mdpi.com [mdpi.com]
- 3. researchgate.net [researchgate.net]
- 4. Design, Synthesis, and Biological Evaluation of 2-Substituted Aniline Pyrimidine Derivatives as Potent Dual Mer/c-Met Inhibitors - PMC [pmc.ncbi.nlm.nih.gov]
- To cite this document: BenchChem. [Structure-activity relationship of Boc-protected 2-ethynylaniline derivatives]. BenchChem, [2026]. [Online PDF]. Available at: [https://www.benchchem.com/product/b177329/docs#structure-activity-relationship-of-boc-protected-2-ethynylaniline-derivatives]

---

### Disclaimer & Data Validity:

The information provided in this document is for Research Use Only (RUO) and is strictly not intended for diagnostic or therapeutic procedures. While BenchChem strives to provide accurate protocols, we make no warranties, express or implied, regarding the fitness of this product for every specific experimental setup.

**Technical Support:** The protocols provided are for reference purposes. Unsure if this reagent suits your experiment?

**Need Industrial/Bulk Grade?** [Request Custom Synthesis Quote](#)

## BenchChem

Our mission is to be the trusted global source of essential and advanced chemicals, empowering scientists and researchers to drive progress in science and industry.

### Contact

Address: 3281 E Guasti Rd

Ontario, CA 91761, United States

Phone: (601) 213-4426

Email: [info@benchchem.com](mailto:info@benchchem.com)

Contact our Ph.D. Support Team for a compatibility check