

GC-MS analysis of 4-(methoxymethoxy)-1H-indole

Author: BenchChem Technical Support Team. **Date:** April 2026

Compound of Interest

Compound Name: 4-(methoxymethoxy)-1H-indole

CAS No.: 133416-33-8

Cat. No.: B177869

[Get Quote](#)

Application Note: GC-MS Analysis of **4-(Methoxymethoxy)-1H-indole** – Method Optimization and Mechanistic Insights

Executive Overview

The compound **4-(methoxymethoxy)-1H-indole** is a critical synthetic intermediate, frequently utilized in the development of complex pharmaceuticals and natural product analogs. The precise quantification and purity profiling of this compound via Gas Chromatography-Mass Spectrometry (GC-MS) presents a unique analytical challenge due to the thermal and chemical properties of its protecting group. This application note details a robust, self-validating GC-MS protocol designed to prevent artifactual degradation while ensuring high-resolution separation and definitive mass spectral identification.

Mechanistic Rationale & System Design

The methoxymethyl (MOM) ether is routinely employed to protect the C4-hydroxyl group of the indole core during multi-step syntheses, such as the[1]. While MOM ethers are highly stable under strongly basic conditions, they are susceptible to acid-catalyzed cleavage and thermal degradation.

In gas-phase analysis, this lability dictates the experimental design. If the GC injection port is too hot or contains active acidic sites (e.g., degraded glass wool or accumulated matrix residue), the MOM group will undergo thermal cleavage prior to entering the column[2]. This degradation produces 4-hydroxy-1H-indole as an artifact, leading to inaccurate purity assessments. Therefore, the causality behind our method design relies on strictly controlling the thermal energy in the inlet (capping at 240 °C) and utilizing ultra-inert consumables to preserve the structural integrity of the analyte. Furthermore, standard GC-MS parameters for indole derivatives require a slightly polar stationary phase to ensure baseline resolution[3].

Experimental Workflow Visualization

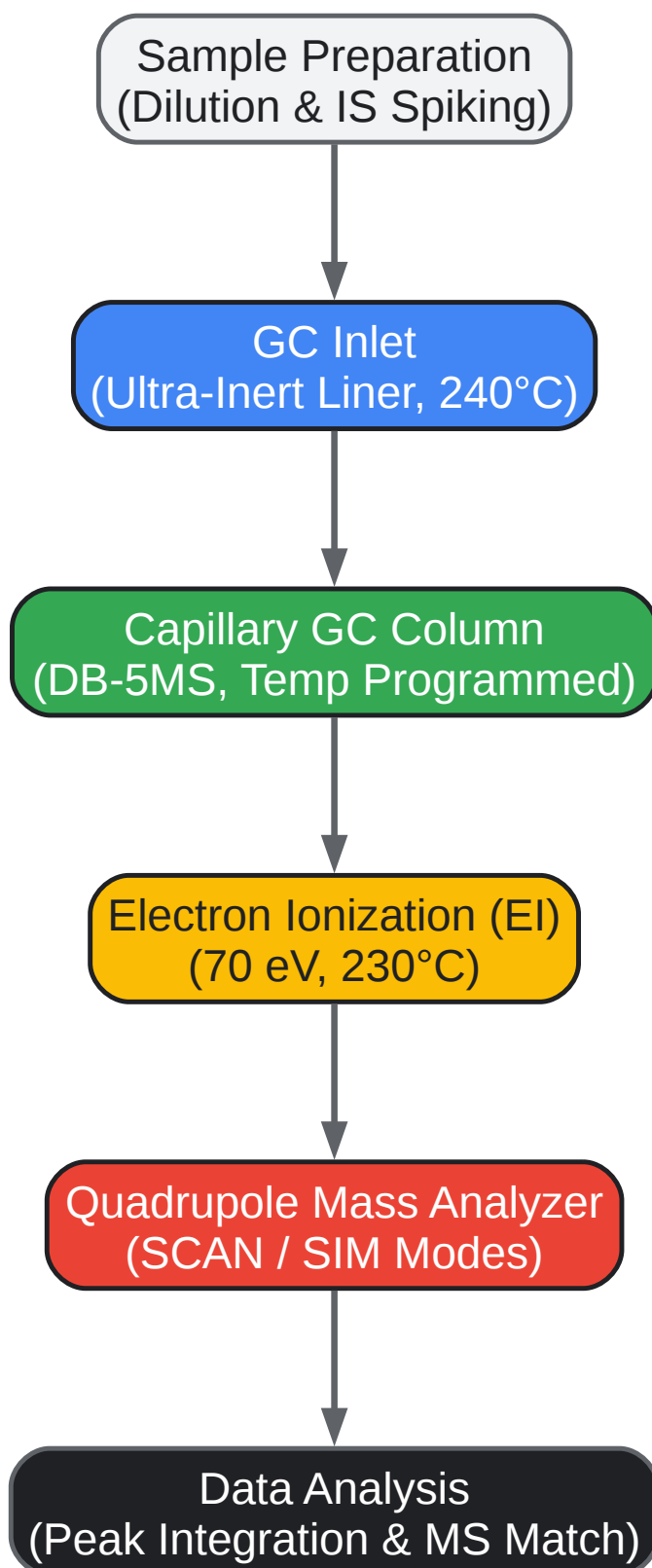

[Click to download full resolution via product page](#)

Figure 1: GC-MS workflow for **4-(methoxymethoxy)-1H-indole**, emphasizing thermal control.

Self-Validating Experimental Protocol

To ensure trustworthiness, this protocol is engineered as a self-validating system. It employs internal standards and diagnostic fragmentation ratios to automatically flag instrument degradation or sample preparation errors.

Step 1: Matrix Preparation & Internal Standard (IS) Spiking

- Accurately weigh 1.0 mg of **4-(methoxymethoxy)-1H-indole** and dissolve it in 1.0 mL of anhydrous, GC-grade ethyl acetate to create a 1 mg/mL stock solution.
- Dilute the stock to a working concentration of 50 µg/mL.
- Self-Validation Step: Spike the working solution with 5-fluoroindole (Internal Standard) to a final concentration of 10 µg/mL. Causality: 5-fluoroindole shares similar ionization efficiency and retention behavior with the target analyte but possesses a distinct mass (m/z 135). Monitoring the IS peak area across technical replicates ensures that any drop in signal is definitively traced to injection volume errors rather than matrix suppression.

Step 2: System Suitability Test (SST)

- Inject a solvent blank (ethyl acetate) to confirm column baseline stability and the absence of ghost peaks.
- Inject the spiked working solution.
- Self-Validation Step: Calculate the peak area ratio of m/z 177 (intact product) to m/z 133 (deprotected 4-hydroxyindole artifact). If the ratio falls below 95:5, the system fails validation. Causality: An elevated m/z 133 signal acts as an "internal thermometer" and chemical sensor, indicating that the GC inlet liner has developed active sites or is operating at an excessively high temperature, necessitating immediate maintenance.

Step 3: GC-MS Acquisition

- Execute the run using the optimized parameters detailed in Table 1.
- Utilize a 5:1 split ratio during injection. Causality: Indole derivatives possess active amine hydrogens that can easily overload the stationary phase. A split injection prevents column

overloading, ensuring sharp, symmetrical peaks for accurate integration.

Quantitative Data & Spectral Interpretation

Table 1: GC-MS Operational Parameters

Parameter	Optimized Setting	Mechanistic Rationale
Column	DB-5MS (30 m × 0.25 mm, 0.25 μm)	(5%-phenyl)-methylpolysiloxane provides optimal polarity for semi-volatile indoles.
Carrier Gas	Helium, Constant Flow at 1.0 mL/min	Ensures consistent retention times across the temperature gradient.
Inlet Temperature	240 °C	High enough for rapid volatilization, low enough to prevent MOM thermal cleavage.
Injection Mode	Split (5:1), 1 μL volume	Prevents column overload and peak fronting.
Oven Program	100 °C (1 min) → 15 °C/min to 280 °C (5 min)	Gradient focuses the analyte band and elutes high-boiling impurities.
Ion Source (EI)	70 eV, 230 °C	Standardized energy for reproducible library matching.

Table 2: Diagnostic Mass Spectral Fragmentation

Fragment (m/z)	Relative Abundance	Structural Assignment
177	Moderate	Molecular Ion [M] ⁺ of 4-(methoxymethoxy)-1H-indole.
132	High	[M - CH ₂ OCH ₃] ⁺ (Loss of the methoxymethyl radical).
116	Moderate	Indole core fragment following complete cleavage of the C4 substituent.
45	Base Peak (100%)	[CH ₃ OCH ₂] ⁺ (Methoxymethyl cation), highly diagnostic for MOM ethers.

Troubleshooting Matrix

Symptom	Root Cause	Corrective Action
Elevated m/z 133 Peak	Thermal or acid-catalyzed cleavage of the MOM ether in the GC inlet.	Replace the inlet liner with a new ultra-inert, deactivated liner. Reduce inlet temperature to 220 °C.
Peak Tailing	Adsorption of the indole N-H group to active sites on the column or liner.	Perform inlet maintenance. Trim 10–20 cm from the front of the capillary column.
IS Area Fluctuation (>5%)	Syringe clogging, inlet septum leak, or inconsistent split flow.	Replace the autosampler syringe and inlet septum. Verify carrier gas flow rates.

References

- Kodet, J. G., & Wiemer, D. F. (2013). Synthesis of Indole Analogues of the Natural Schweinfurthins. *Journal of Organic Chemistry*, 78(18), 9291–9302. URL:[[Link](#)]
- Rutkowska, M., et al. (2016). Gas Chromatography-Mass Spectrometry (GC-MS) Analysis of Indole Alkaloids Isolated from *Catharanthus roseus* (L.) G. Don Cultivated Conventionally

and Derived from In vitro Cultures. Notulae Botanicae Horti Agrobotanici Cluj-Napoca, 44(1).

URL:[[Link](#)]

Need Custom Synthesis?

BenchChem offers custom synthesis for rare earth carbides and specific isotopic labeling.

Email: info@benchchem.com or [Request Quote Online](#).

Sources

- [1. Synthesis of Indole Analogues of the Natural Schweinfurthins - PMC](#)
[[pmc.ncbi.nlm.nih.gov](https://pubmed.ncbi.nlm.nih.gov)]
- [2. pdf.benchchem.com](#) [pdf.benchchem.com]
- [3. notulaebotanicae.ro](#) [notulaebotanicae.ro]
- To cite this document: BenchChem. [GC-MS analysis of 4-(methoxymethoxy)-1H-indole]. BenchChem, [2026]. [Online PDF]. Available at: [<https://www.benchchem.com/product/b177869/docs#gc-ms-analysis-of-4-methoxymethoxy-1h-indole>]

Disclaimer & Data Validity:

The information provided in this document is for Research Use Only (RUO) and is strictly not intended for diagnostic or therapeutic procedures. While BenchChem strives to provide accurate protocols, we make no warranties, express or implied, regarding the fitness of this product for every specific experimental setup.

Technical Support: The protocols provided are for reference purposes. Unsure if this reagent suits your experiment?

Need Industrial/Bulk Grade? [Request Custom Synthesis Quote](#)

BenchChem

Our mission is to be the trusted global source of essential and advanced chemicals, empowering scientists and researchers to drive progress in science and industry.

Contact

Address: 3281 E Guasti Rd
Ontario, CA 91761, United States
Phone: (601) 213-4426
Email: info@benchchem.com

[Contact our Ph.D. Support Team for a compatibility check](#)