

A Comparative Guide to the Electro-Optical Properties of Liquid Crystal Intermediates

Author: BenchChem Technical Support Team. **Date:** May 2026

Compound of Interest

Compound Name:	<i>trans-4-[2-(4-Pentylcyclohexyl)ethyl]cyclohexanone</i>
CAS No.:	121040-08-2
Cat. No.:	B177444

[Get Quote](#)

For Researchers, Scientists, and Drug Development Professionals

This guide provides an objective comparison of the electro-optical properties of various liquid crystal intermediates, supported by experimental data. Understanding these properties is crucial for the design and synthesis of advanced liquid crystal mixtures for a wide range of applications, from high-resolution displays to advanced photonic devices.

Key Electro-Optical Properties: A Comparative Analysis

The performance of a liquid crystal is primarily dictated by its birefringence (Δn), dielectric anisotropy ($\Delta\epsilon$), and switching time (τ). These parameters are intrinsically linked to the molecular structure of the liquid crystal intermediates. Below is a summary of these properties for representative classes of calamitic (rod-shaped) liquid crystal intermediates.

Liquid Crystal Intermediate Class	Representative Structure	Birefringence (Δn)	Dielectric Anisotropy ($\Delta\epsilon$)	Switching Time (τ)	Key Structural Features & Significance
Cyanobiphenyls	4'-pentyl-4-cyanobiphenyl (5CB)	~0.18 - 0.22	Large, Positive (~+10)	Milliseconds	Strong polar cyano (-CN) group leads to a large positive $\Delta\epsilon$, enabling low-voltage switching. The biphenyl core provides a good balance of properties. ^{[1][2][3]}
Phenyl Tolanes	Tolane-based structures	High (~0.2 - 0.5)	Variable (can be positive or negative)	Milliseconds to sub-milliseconds	The tolane core (with a triple bond) extends the conjugation length, resulting in high birefringence, which is advantageous for applications requiring a large phase shift. ^{[1][2]}

Fluorinated Terphenyls	Laterally fluorinated terphenyls	High (-0.15 - 0.3)	Negative or Positive	Milliseconds	Fluorine substitution significantly influences the dielectric anisotropy. Lateral fluorine atoms can lead to a negative $\Delta\epsilon$, which is useful in vertically aligned (VA) display modes. ^{[3][4]}
Isothiocyanates	Phenyl-tolane isothiocyanates	Very High (-0.4 - 0.7)	Variable	Milliseconds	The isothiocyanate (-NCS) group contributes to a very high birefringence due to its high polarizability. ^{[1][2]}

Structure-Property Relationships

The electro-optical properties of liquid crystal intermediates are a direct consequence of their molecular architecture. The following diagram illustrates the key relationships between molecular structure and the resulting electro-optical performance.

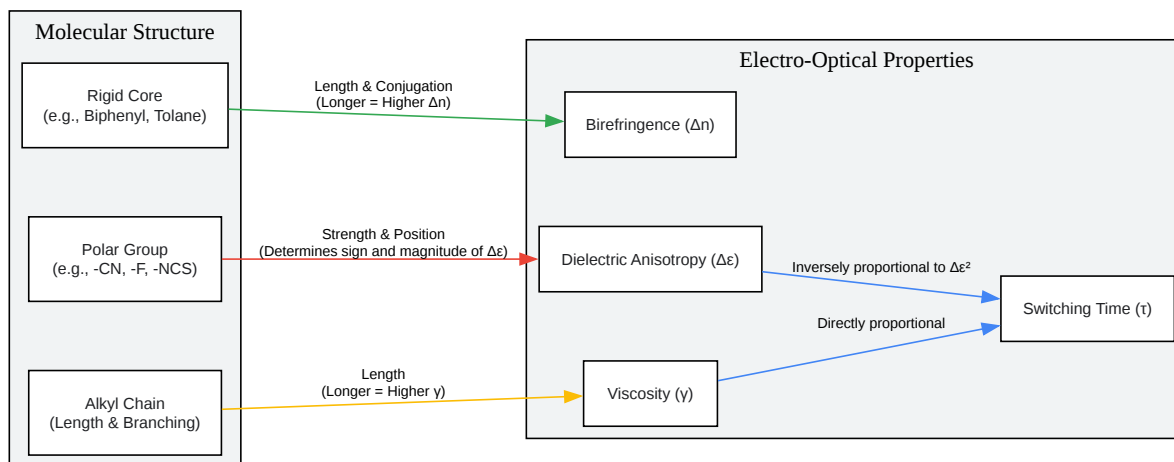

[Click to download full resolution via product page](#)

Caption: Relationship between molecular structure and electro-optical properties.

Experimental Protocols

Accurate characterization of the electro-optical properties of liquid crystal intermediates is essential for their development and application. The following are detailed methodologies for key experiments.

Measurement of Birefringence (Δn)

Principle: Birefringence is the difference between the extraordinary (n_e) and ordinary (n_o) refractive indices of the liquid crystal. It is a measure of the optical anisotropy of the material.

Method: Abbe Refractometer[5][6][7][8][9]

- Calibration: Calibrate the Abbe refractometer using a standard sample with a known refractive index (e.g., distilled water).

- **Sample Preparation:** Place a few drops of the liquid crystal intermediate onto the prism of the refractometer. For calamitic liquid crystals, measurements are typically made in the nematic phase.
- **Measurement of n_o :**
 - Use a polarizer to ensure the light entering the liquid crystal is polarized perpendicular to the director (the average direction of the long molecular axis). In a homeotropically aligned cell (molecules perpendicular to the substrate), this is straightforward.
 - Adjust the refractometer to find the critical angle, and read the ordinary refractive index (n_o) from the scale.
- **Measurement of n_e :**
 - Rotate the polarizer by 90 degrees so that the light is polarized parallel to the director.
 - Adjust the refractometer to find the new critical angle and read the extraordinary refractive index (n_e).
- **Calculation:** Calculate the birefringence using the formula: $\Delta n = n_e - n_o$.

Measurement of Dielectric Anisotropy ($\Delta\epsilon$)

Principle: Dielectric anisotropy is the difference between the dielectric permittivity parallel ($\epsilon_{||}$) and perpendicular (ϵ_{\perp}) to the liquid crystal director. It determines how the liquid crystal molecules will align in an electric field.

Method: Dielectric Spectroscopy[10][11][12][13][14][15]

- **Cell Preparation:** Fill a liquid crystal cell with parallel plate electrodes (e.g., ITO-coated glass) with the liquid crystal intermediate. The cell should have a known thickness.
- **Measurement of ϵ_{\perp} :**
 - Apply a low-frequency AC electric field across the electrodes.

- Use a magnetic field to align the liquid crystal director parallel to the electrode surfaces (planar alignment).
- Measure the capacitance of the cell using an LCR meter.
- Calculate the perpendicular dielectric permittivity (ϵ_{\perp}) from the capacitance, cell area, and thickness.
- Measurement of ϵ_{\parallel} :
 - Remove the magnetic field and apply a sufficiently high AC electric field to align the liquid crystal director perpendicular to the electrode surfaces (homeotropic alignment).
 - Measure the capacitance of the cell.
 - Calculate the parallel dielectric permittivity (ϵ_{\parallel}).
- Calculation: Calculate the dielectric anisotropy using the formula: $\Delta\epsilon = \epsilon_{\parallel} - \epsilon_{\perp}$.

Measurement of Switching Time (τ)

Principle: Switching time refers to the time it takes for the liquid crystal molecules to reorient in response to an applied electric field (rise time, τ_{on}) and to relax back to their original state when the field is removed (decay time, τ_{off}).

Method: Transient Current Measurement[16][17][18]

- Experimental Setup:
 - Place a planar-aligned liquid crystal cell between crossed polarizers.
 - A light source (e.g., a He-Ne laser) is passed through the setup, and the transmitted light intensity is measured by a photodetector connected to an oscilloscope.
 - A function generator is used to apply a square wave voltage to the liquid crystal cell.
- Measurement of Rise Time (τ_{on}):

- Apply a voltage pulse to the cell that is sufficient to switch the liquid crystal molecules to the homeotropic state.
- Measure the time it takes for the transmitted light intensity to change from 10% to 90% of its maximum value. This is the rise time.
- Measurement of Decay Time (τ_{off}):
 - Turn off the voltage pulse.
 - Measure the time it takes for the transmitted light intensity to decay from 90% to 10% of its maximum value. This is the decay time.

Experimental Workflow for Characterization

The following diagram outlines a typical workflow for the synthesis and electro-optical characterization of a new liquid crystal intermediate.

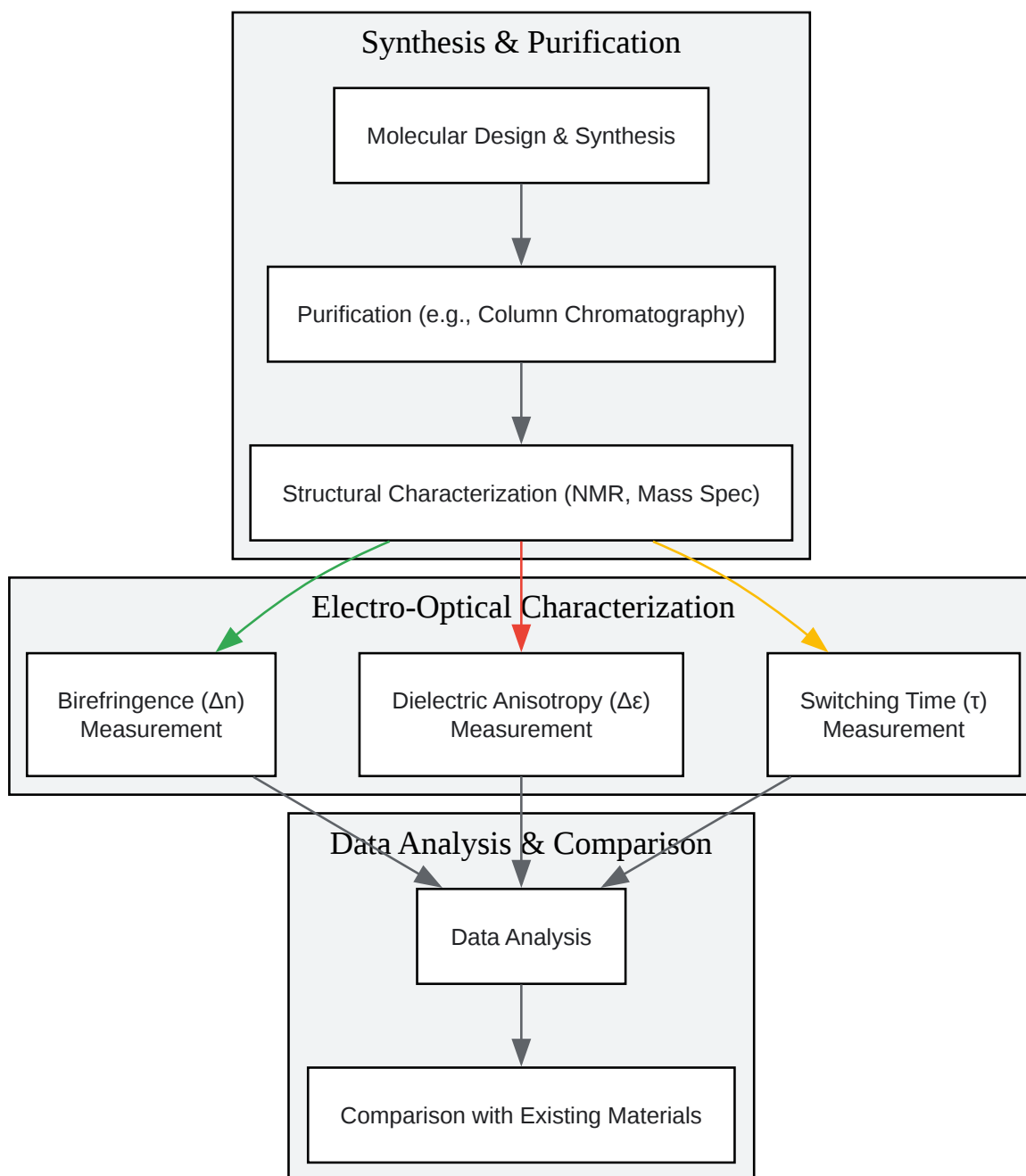

[Click to download full resolution via product page](#)

Caption: Experimental workflow for liquid crystal characterization.

Need Custom Synthesis?

BenchChem offers custom synthesis for rare earth carbides and specific isotopic labeling.

Email: info@benchchem.com or [Request Quote Online](#).

References

- [1. mdpi.com \[mdpi.com\]](#)
- [2. researchgate.net \[researchgate.net\]](#)
- [3. mdpi.com \[mdpi.com\]](#)
- [4. Negative Dielectric Anisotropy Liquid Crystal with Improved Photo-Stability, Anti-Flicker, and Transmittance for 8K Display Applications - PMC \[pmc.ncbi.nlm.nih.gov\]](#)
- [5. tandfonline.com \[tandfonline.com\]](#)
- [6. researchgate.net \[researchgate.net\]](#)
- [7. researchgate.net \[researchgate.net\]](#)
- [8. Abbe's Refractometer \(Procedure\) : Modern Physics Virtual Lab : Physical Sciences : Amrita Vishwa Vidyapeetham Virtual Lab \[vlab.amrita.edu\]](#)
- [9. carlroth.com \[carlroth.com\]](#)
- [10. pubs.aip.org \[pubs.aip.org\]](#)
- [11. researchgate.net \[researchgate.net\]](#)
- [12. researchgate.net \[researchgate.net\]](#)
- [13. Liquid Crystals: a Simple View on a Complex Matter \[personal.kent.edu\]](#)
- [14. mdpi.com \[mdpi.com\]](#)
- [15. researchgate.net \[researchgate.net\]](#)
- [16. researchgate.net \[researchgate.net\]](#)
- [17. Determination of Rotational Viscosity of Nematic Liquid Crystals from Transient Current: Numerical Analysis and Experim... \[ouci.dntb.gov.ua\]](#)
- [18. discovery.researcher.life \[discovery.researcher.life\]](#)
- To cite this document: BenchChem. [A Comparative Guide to the Electro-Optical Properties of Liquid Crystal Intermediates]. BenchChem, [2026]. [Online PDF]. Available at: [<https://www.benchchem.com/product/b177444/docs#a-comparative-guide-to-the-electro-optical-properties-of-liquid-crystal-intermediates>]

Disclaimer & Data Validity:

The information provided in this document is for Research Use Only (RUO) and is strictly not intended for diagnostic or therapeutic procedures. While BenchChem strives to provide accurate protocols, we make no warranties, express or implied, regarding the fitness of this product for every specific experimental setup.

Technical Support: The protocols provided are for reference purposes. Unsure if this reagent suits your experiment?

Need Industrial/Bulk Grade? [Request Custom Synthesis Quote](#)

BenchChem

Our mission is to be the trusted global source of essential and advanced chemicals, empowering scientists and researchers to drive progress in science and industry.

Contact

Address: 3281 E Guasti Rd
Ontario, CA 91761, United States
Phone: (601) 213-4426
Email: info@benchchem.com

[Contact our Ph.D. Support Team for a compatibility check](#)