

# Independent Verification of FMP-API-1's Mechanism of Action: A Comparative Guide

**Author:** BenchChem Technical Support Team. **Date:** April 2026

## Compound of Interest

Compound Name: FMP-API-1  
CAS No.: 16523-28-7  
Cat. No.: B176353

[Get Quote](#)

For Researchers, Scientists, and Drug Development Professionals

This guide provides an objective comparison of **FMP-API-1**, a small molecule modulator of the A-kinase anchoring protein (AKAP)-Protein Kinase A (PKA) interaction, with alternative inhibitors. Its purpose is to offer a comprehensive resource for the independent verification of **FMP-API-1**'s mechanism of action, complete with supporting experimental data and detailed protocols.

## Introduction to FMP-API-1

**FMP-API-1**, with the chemical name 3,3'-diamino-4,4'-dihydroxydiphenylmethane, is a notable small molecule that disrupts the interaction between A-kinase anchoring proteins (AKAPs) and Protein Kinase A (PKA).[1] AKAPs are scaffold proteins that compartmentalize PKA to specific subcellular locations, thereby ensuring the specificity of cAMP-PKA signaling.[2] **FMP-API-1** exhibits a dual mechanism of action: it not only inhibits the AKAP-PKA interaction by binding to an allosteric site on the regulatory subunits of PKA but also directly activates PKA.[3] This unique characteristic makes it a valuable tool for studying compartmentalized cAMP signaling

and a potential therapeutic lead for conditions such as chronic heart failure and nephrogenic diabetes insipidus.[1][4]

## Comparison with Alternative Inhibitors

The primary alternatives to the small molecule **FMP-API-1** are peptide-based inhibitors derived from the PKA-binding domain of AKAPs. The most well-established of these is Ht31.[5][6] Further developments have led to modified and optimized peptides, including stearylated (st-Ht31) for improved cell permeability, and stapled peptides (STAD-2 and RI-STAD-2) for enhanced stability and isoform selectivity.[7][8]

## Quantitative Comparison of Inhibitor Performance

The following table summarizes key quantitative data for **FMP-API-1** and its principal alternatives. Direct comparison of potency should be made with caution, as experimental conditions can vary between studies.

| Inhibitor                           | Type              | Target                           | Assay                           | Potency  | Reference |
|-------------------------------------|-------------------|----------------------------------|---------------------------------|--|-----------|
| FMP-API-1 derivative (FMP-API-1/27) | Small Molecule    | AKAP-PKA RII $\beta$ Interaction | Surface Plasmon Resonance (SPR) | IC50 = 10.7 $\pm$ 1.8 $\mu$ M                          |           |
| Ht31                                | Peptide           | AKAP-PKA RII Interaction         | Varies                          | Kd = 2-4 nM  | [5]       |
| AKAP-IS                             | Peptide           | AKAP-PKA RII Interaction         | Varies                          | Kd < 1 nM  | [9]       |
| st-Ht31                             | Stearated Peptide | AKAP-PKA RII Interaction         | Cell-based                      | Effective at 5-20 $\mu$ M                              |           |
| STAD-2                              | Stapled Peptide   | AKAP-PKA RII Interaction         | Varies                          | Kd (RII $\alpha$ ) = 35 nM, Kd (RII $\beta$ ) = 75 nM  | [7]       |
| RI-STAD-2                           | Stapled Peptide   | AKAP-PKA RI Interaction          | Varies                          | Kd (RI $\alpha$ ) = 6.2 nM, Kd (RI $\beta$ ) = 12.1 nM |           |

## Signaling Pathway and Mechanism of Action

The diagram below illustrates the canonical AKAP-PKA signaling pathway and the points of intervention for **FMP-API-1** and peptide inhibitors. In the basal state, the PKA holoenzyme, consisting of two regulatory (R) and two catalytic (C) subunits, is inactive and anchored to a specific subcellular location by an AKAP. Upon binding of cyclic AMP (cAMP) to the R subunits, the C subunits are released to phosphorylate downstream targets. **FMP-API-1** disrupts the anchoring of the PKA holoenzyme, while peptide inhibitors competitively block the binding of AKAPs to the R subunits. A unique feature of **FMP-API-1** is its additional ability to allosterically activate PKA.

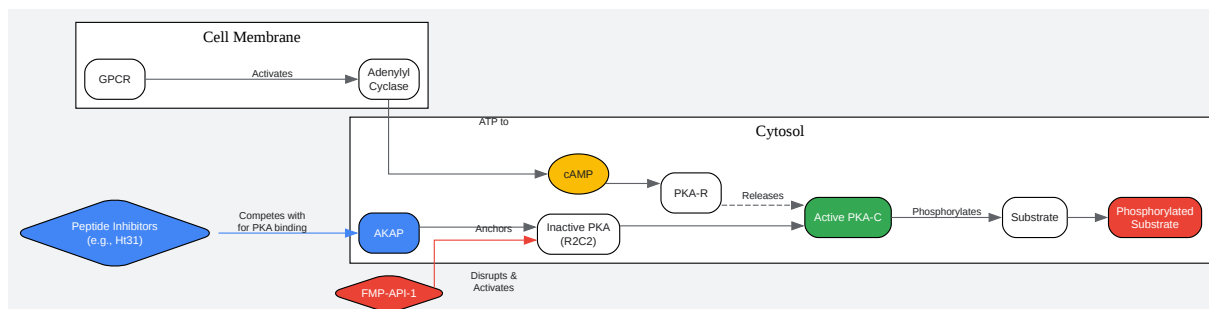

[Click to download full resolution via product page](#)

AKAP-PKA signaling and inhibitor intervention points.

## Experimental Protocols

### Verification of AKAP-PKA Interaction Disruption by ELISA

This protocol describes an Enzyme-Linked Immunosorbent Assay (ELISA) to quantify the disruption of the AKAP-PKA interaction by an inhibitor.[3][10]

Materials:

- High-binding 96-well microplate
- Recombinant PKA regulatory subunits (e.g., RII $\alpha$ )
- Recombinant AKAP protein (e.g., AKAP18 $\delta$ )
- Inhibitor (**FMP-API-1** or alternatives)

- Primary antibody against the AKAP protein
- HRP-conjugated secondary antibody
- TMB substrate
- Stop solution (e.g., 1 M H<sub>2</sub>SO<sub>4</sub>)
- Wash buffer (e.g., PBS with 0.05% Tween-20)
- Blocking buffer (e.g., 5% BSA in PBS)
- Plate reader

Procedure:

- Coating: Coat the wells of a 96-well plate with PKA RII $\alpha$  subunits (e.g., 1-5  $\mu$ g/mL in PBS) overnight at 4°C.
- Washing: Wash the plate three times with wash buffer.
- Blocking: Block non-specific binding sites by adding 200  $\mu$ L of blocking buffer to each well and incubating for 1-2 hours at room temperature.
- Washing: Wash the plate three times with wash buffer.
- Inhibitor and Ligand Incubation: Add the inhibitor at various concentrations to the wells, followed by the addition of the recombinant AKAP protein. Incubate for 1-2 hours at room temperature. Include a control with no inhibitor.
- Washing: Wash the plate three times with wash buffer to remove unbound AKAP.
- Primary Antibody Incubation: Add the primary antibody against the AKAP protein to each well and incubate for 1 hour at room temperature.
- Washing: Wash the plate three times with wash buffer.

- Secondary Antibody Incubation: Add the HRP-conjugated secondary antibody and incubate for 1 hour at room temperature.
- Washing: Wash the plate five times with wash buffer.
- Detection: Add TMB substrate to each well and incubate in the dark until a color develops (typically 15-30 minutes).
- Stopping Reaction: Stop the reaction by adding the stop solution.
- Measurement: Read the absorbance at 450 nm using a plate reader. The signal intensity is proportional to the amount of bound AKAP, and a decrease in signal in the presence of the inhibitor indicates disruption of the interaction.

## Kinetic Analysis of Inhibitor Binding by Surface Plasmon Resonance (SPR)

This protocol outlines the use of SPR to measure the binding kinetics and affinity of an inhibitor to the PKA regulatory subunit.[\[4\]](#)[\[11\]](#)

Materials:

- SPR instrument and sensor chip (e.g., CM5)
- Recombinant PKA regulatory subunits (ligand)
- Inhibitor (analyte)
- Immobilization buffer (e.g., 10 mM sodium acetate, pH 4.5)
- Running buffer (e.g., HBS-EP+)
- Regeneration solution (e.g., 10 mM glycine-HCl, pH 2.5)
- Amine coupling kit (EDC, NHS)

Procedure:

- **Surface Preparation:** Activate the sensor chip surface using a mixture of EDC and NHS according to the manufacturer's instructions.
- **Ligand Immobilization:** Inject the PKA regulatory subunits over the activated surface to achieve the desired immobilization level.
- **Blocking:** Deactivate any remaining active esters on the surface by injecting ethanolamine.
- **Analyte Injection:** Inject a series of concentrations of the inhibitor (analyte) over the ligand-immobilized surface at a constant flow rate.
- **Dissociation:** After the association phase, allow the running buffer to flow over the surface to monitor the dissociation of the inhibitor.
- **Regeneration:** If necessary, inject the regeneration solution to remove any remaining bound analyte.
- **Data Analysis:** Fit the resulting sensorgrams to an appropriate binding model (e.g., 1:1 Langmuir binding) to determine the association rate constant ( $k_a$ ), dissociation rate constant ( $k_d$ ), and the equilibrium dissociation constant ( $K_D$ ).

## Assessment of PKA Activation by Western Blot

This protocol describes how to detect the phosphorylation of a known PKA substrate as a measure of PKA activation in cells treated with an inhibitor.[\[12\]](#)[\[13\]](#)

Materials:

- Cell culture reagents
- Inhibitor (**FMP-API-1**)
- Lysis buffer containing protease and phosphatase inhibitors
- SDS-PAGE gels and electrophoresis apparatus
- Transfer apparatus and PVDF or nitrocellulose membranes

- Blocking buffer (e.g., 5% BSA in TBST)
- Primary antibody specific for the phosphorylated form of a PKA substrate (e.g., phospho-CREB Ser133)
- Primary antibody for the total form of the PKA substrate (loading control)
- HRP-conjugated secondary antibody
- ECL detection reagent
- Imaging system

#### Procedure:

- Cell Treatment: Treat cultured cells with the inhibitor (e.g., **FMP-API-1**) at various concentrations and for different time points. Include appropriate controls (e.g., untreated, vehicle control, positive control like forskolin).
- Cell Lysis: Wash the cells with ice-cold PBS and lyse them in lysis buffer.
- Protein Quantification: Determine the protein concentration of the lysates using a protein assay (e.g., BCA assay).
- Sample Preparation: Prepare samples for SDS-PAGE by adding Laemmli buffer and boiling for 5 minutes.
- Electrophoresis: Separate the proteins by SDS-PAGE.
- Transfer: Transfer the separated proteins to a PVDF or nitrocellulose membrane.
- Blocking: Block the membrane with blocking buffer for at least 1 hour at room temperature.
- Primary Antibody Incubation: Incubate the membrane with the phospho-specific primary antibody overnight at 4°C.
- Washing: Wash the membrane three times with TBST for 10 minutes each.

- Secondary Antibody Incubation: Incubate the membrane with the HRP-conjugated secondary antibody for 1 hour at room temperature.
- Washing: Wash the membrane three times with TBST for 10 minutes each.
- Detection: Apply the ECL detection reagent and visualize the bands using an imaging system.
- Stripping and Re-probing: To normalize for protein loading, the membrane can be stripped and re-probed with an antibody against the total form of the substrate protein.

## Experimental Workflow Verification

The following diagram outlines a logical workflow for the independent verification of **FMP-API-1**'s mechanism of action, from initial in vitro validation to cellular assays.

Workflow for verifying **FMP-API-1**'s mechanism of action.

### *Need Custom Synthesis?*

*BenchChem offers custom synthesis for rare earth carbides and specific isotopic labeling.*

*Email: [info@benchchem.com](mailto:info@benchchem.com) or [Request Quote Online](#).*

## References

- [1. medchemexpress.com \[medchemexpress.com\]](https://www.medchemexpress.com)
- [2. benchchem.com \[benchchem.com\]](https://www.benchchem.com)
- [3. researchgate.net \[researchgate.net\]](https://www.researchgate.net)
- [4. path.ox.ac.uk \[path.ox.ac.uk\]](https://www.path.ox.ac.uk)
- [5. Utilizing ELISA to Monitor Protein-Protein Interaction | Springer Nature Experiments \[experiments.springernature.com\]](https://www.experiments.springernature.com)
- [6. Principle and Protocol of Surface Plasmon Resonance \(SPR\) - Creative BioMart \[creativebiomart.net\]](https://www.creativebiomart.net)
- [7. Investigating PKA-R11 specificity using analogs of the PKA:AKAP peptide inhibitor STAD-2 - PMC \[pmc.ncbi.nlm.nih.gov\]](https://pubmed.ncbi.nlm.nih.gov)

- [8. pubs.acs.org \[pubs.acs.org\]](https://pubs.acs.org)
- [9. Biochemical Analysis of AKAP-anchored PKA Signaling Complexes - PMC \[pmc.ncbi.nlm.nih.gov\]](https://pubmed.ncbi.nlm.nih.gov/)
- [10. Surface Plasmon Resonance Protocol & Troubleshooting - Creative Biolabs \[creativebiolabs.net\]](https://www.creativebiolabs.net/)
- [11. researchgate.net \[researchgate.net\]](https://www.researchgate.net/)
- [12. Indirect and Direct ELISA | Abcam \[abcam.com\]](https://www.abcam.com/)
- [13. researchgate.net \[researchgate.net\]](https://www.researchgate.net/)
- To cite this document: BenchChem. [Independent Verification of FMP-API-1's Mechanism of Action: A Comparative Guide]. BenchChem, [2026]. [Online PDF]. Available at: [\[https://www.benchchem.com/product/b176353/docs#independent-verification-of-fmp-api-1-s-mechanism-of-action-a-comparative-guide\]](https://www.benchchem.com/product/b176353/docs#independent-verification-of-fmp-api-1-s-mechanism-of-action-a-comparative-guide)

---

#### Disclaimer & Data Validity:

The information provided in this document is for Research Use Only (RUO) and is strictly not intended for diagnostic or therapeutic procedures. While BenchChem strives to provide accurate protocols, we make no warranties, express or implied, regarding the fitness of this product for every specific experimental setup.

**Technical Support:** The protocols provided are for reference purposes. Unsure if this reagent suits your experiment?

**Need Industrial/Bulk Grade?** [Request Custom Synthesis Quote](#)

## BenchChem

Our mission is to be the trusted global source of essential and advanced chemicals, empowering scientists and researchers to drive progress in science and industry.

#### Contact

Address: 3281 E Guasti Rd  
Ontario, CA 91761, United States  
Phone: (601) 213-4426  
Email: [info@benchchem.com](mailto:info@benchchem.com)

Contact our Ph.D. Support Team for a compatibility check