

Application Notes & Protocols: Strategic Synthesis of Novel Antimicrobial Agents

Author: BenchChem Technical Support Team. **Date:** May 2026

Compound of Interest

Compound Name: 6-Chloro-3-methylpyrimidin-4(3H)-one
CAS No.: 101079-62-3
Cat. No.: B176724

[Get Quote](#)

A Guide for Researchers and Drug Development Professionals

The escalating crisis of antimicrobial resistance (AMR) necessitates a paradigm shift in the discovery and development of new anti-infective agents. The ability of pathogens to rapidly evolve and neutralize the efficacy of existing drugs presents a formidable challenge to global health.[1][2] Consequently, synthetic chemistry has become a critical frontline in this battle, moving beyond traditional antibiotic scaffolds to create novel molecules that can circumvent established resistance mechanisms.[3][4]

This guide provides an in-depth exploration of modern synthetic strategies for the development of new antimicrobial agents. It is designed for researchers at the bench, offering not just protocols, but the strategic rationale behind the synthetic choices and the essential validation techniques required to confirm biological activity. We will delve into key areas of innovation, including the synthesis of molecules that disrupt bacterial communication, mimic natural defense peptides, and are assembled using highly efficient chemical reactions.

Section 1: Strategic Approaches to Antimicrobial Synthesis

The modern synthesis of antimicrobial agents is characterized by a departure from broad-spectrum "magic bullets" towards more targeted and nuanced strategies. These approaches often aim to disarm pathogens rather than kill them outright, thereby imposing less selective pressure for the development of resistance.[5] Other strategies focus on creating molecules that are fundamentally different from existing antibiotics, targeting novel cellular machinery.[6]

A. Targeting Bacterial Communication: Synthesis of Quorum Sensing Inhibitors

Expertise & Rationale: Bacteria coordinate collective behaviors, such as biofilm formation and virulence factor production, through a cell-to-cell communication system known as quorum sensing (QS).[7] This system relies on the production and detection of small signaling molecules called autoinducers.[7][8] By synthetically creating molecules that interfere with this signaling pathway, it's possible to inhibit virulence without directly killing the bacteria, a strategy believed to slow the emergence of resistance.[5][8] Quinazolinone-based compounds have emerged as a promising class of quorum sensing inhibitors (QSIs), particularly against the opportunistic pathogen *Pseudomonas aeruginosa*. [7] They often act by antagonizing the PqsR receptor, a key transcriptional regulator in the pqs QS system.[7][9]

The following diagram illustrates the general principle of quorum sensing and the intervention point for a synthetic inhibitor.

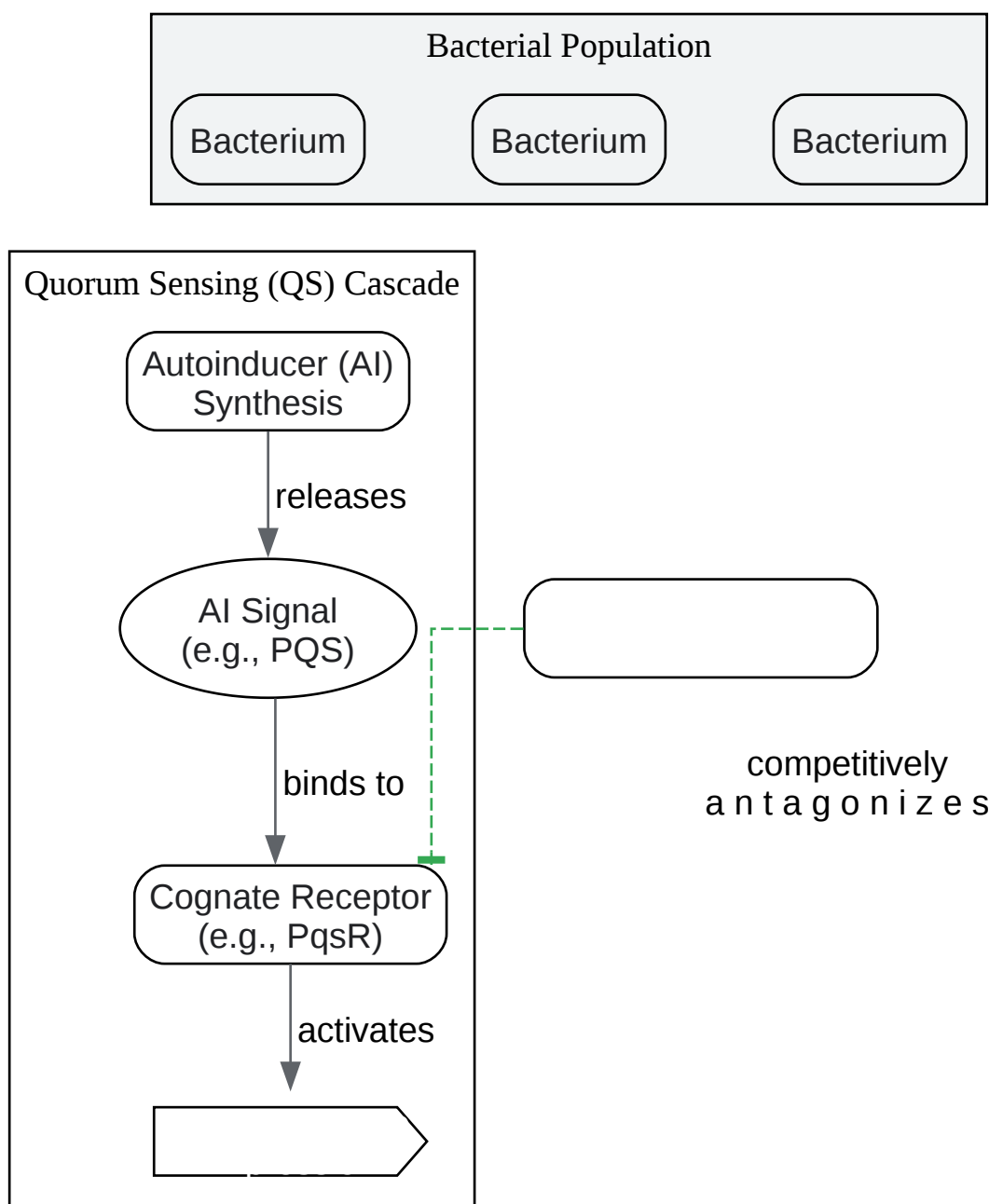

[Click to download full resolution via product page](#)

Caption: Workflow of Quorum Sensing (QS) and inhibition by a synthetic agent.

This protocol is based on established methods for creating the quinazolinone core, a key scaffold for PqsR antagonists.[7] The rationale is a two-step process starting from readily available anthranilic acid derivatives.

Step 1: Synthesis of 2-thioxo-2,3-dihydroquinazolin-4(1H)-one

- Reagents & Setup:
 - Anthranilic acid (1 equivalent)
 - Ammonium thiocyanate (1.2 equivalents)
 - Anhydrous solvent (e.g., Toluene or Xylene)
 - Round-bottom flask equipped with a magnetic stirrer and reflux condenser.
- Procedure:
 - Suspend anthranilic acid in the anhydrous solvent within the reaction flask.
 - Add ammonium thiocyanate to the suspension.
 - Heat the mixture to reflux (typically 110-140°C, depending on the solvent) and maintain for 4-6 hours. Monitor the reaction progress using Thin Layer Chromatography (TLC).
 - Upon completion, allow the reaction mixture to cool to room temperature.
 - The product will often precipitate out of the solution. Collect the solid by vacuum filtration.
 - Wash the collected solid with a cold non-polar solvent (e.g., hexane) to remove impurities.
 - Dry the product under vacuum. Characterize using NMR and Mass Spectrometry.

Step 2: S-Alkylation to Introduce Side Chains

- Reagents & Setup:
 - 2-thioxo-2,3-dihydroquinazolin-4(1H)-one (1 equivalent)
 - Alkyl halide (e.g., benzyl bromide) (1.1 equivalents)
 - Base (e.g., Potassium carbonate, K_2CO_3) (1.5 equivalents)

- Polar aprotic solvent (e.g., Dimethylformamide, DMF)
- Round-bottom flask with a magnetic stirrer.
- Procedure:
 - Dissolve the quinazolinone starting material in DMF in the reaction flask.
 - Add the base (K_2CO_3) to the solution and stir for 15-20 minutes at room temperature to deprotonate the thiol.
 - Add the desired alkyl halide dropwise to the mixture.
 - Allow the reaction to stir at room temperature for 8-12 hours or until completion as indicated by TLC.
 - Quench the reaction by pouring the mixture into ice-water.
 - Collect the resulting precipitate by vacuum filtration.
 - Recrystallize the crude product from a suitable solvent system (e.g., ethanol/water) to obtain the pure S-alkylated quinazolinone.
 - Dry the final compound and confirm its structure and purity via NMR, Mass Spectrometry, and HPLC.

B. Mimicking Nature: Synthesis of Antimicrobial Peptidomimetics

Expertise & Rationale: Antimicrobial peptides (AMPs) are a vital component of the innate immune system in many organisms.^[10] They typically function by disrupting bacterial cell membranes. However, natural AMPs suffer from significant drawbacks for therapeutic use, including high production costs and susceptibility to enzymatic degradation by proteases.^[11] ^[12] Peptidomimetics are molecules that mimic the structural and functional attributes of peptides—such as amphiphilicity and cationic character—but are built from non-natural backbones.^[12] This strategy imparts protease resistance and allows for greater synthetic flexibility, making them a highly attractive new generation of antimicrobial agents.^{[11][12]}

This diagram shows a simplified iterative workflow for building a short peptidomimetic chain, a common strategy in their synthesis.

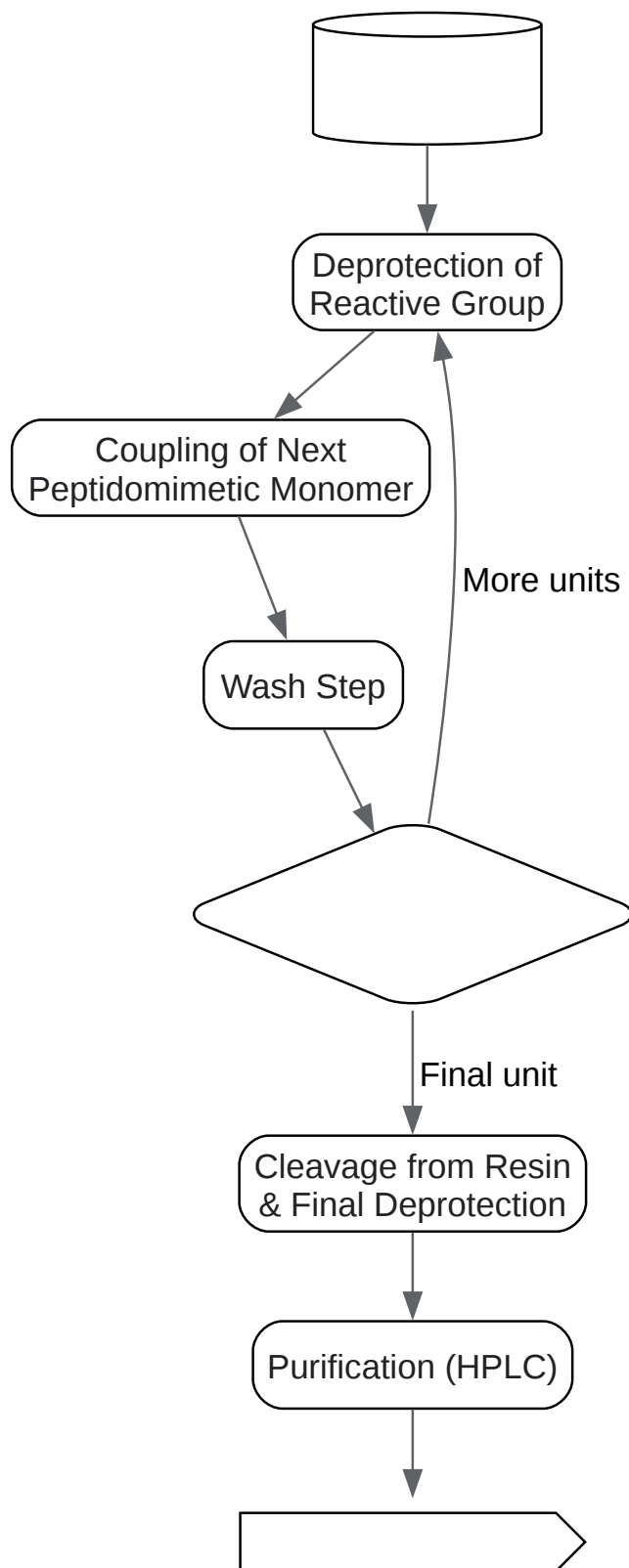

[Click to download full resolution via product page](#)

Caption: Solid-phase synthesis workflow for a peptidomimetic oligomer.

This protocol outlines a general procedure for the solid-phase synthesis of a simple peptidomimetic oligomer, a foundational technique in this field.

- Resin Preparation & First Monomer Coupling:
 - Swell a suitable solid support resin (e.g., Rink Amide resin) in a solvent like DMF for 30 minutes in a peptide synthesis vessel.
 - Remove the Fmoc protecting group from the resin using a 20% piperidine in DMF solution (2 x 10-minute treatments).
 - Wash the resin thoroughly with DMF, followed by Dichloromethane (DCM) and then DMF again.
 - In a separate vial, pre-activate the first Fmoc-protected peptidomimetic monomer (1.5 equivalents) with a coupling agent like HBTU (1.5 equivalents) and a base like DIPEA (3 equivalents) in DMF for 5 minutes.
 - Add the activated monomer solution to the resin and agitate for 2-4 hours.
 - Wash the resin to remove excess reagents.
- Chain Elongation (Iterative Cycle):
 - Deprotection: Remove the Fmoc group from the newly coupled monomer with 20% piperidine in DMF as described above.
 - Wash: Wash the resin thoroughly.
 - Coupling: Pre-activate and couple the next Fmoc-protected monomer as described in Step 1.
 - Repeat: Continue this deprotection-wash-coupling cycle for each monomer until the desired sequence length is achieved.

- Cleavage and Deprotection:
 - After the final monomer is coupled and deprotected, wash the resin with DCM and dry it under a stream of nitrogen.
 - Prepare a cleavage cocktail appropriate for the side-chain protecting groups used (e.g., 95% Trifluoroacetic acid (TFA), 2.5% water, 2.5% triisopropylsilane).
 - Treat the resin with the cleavage cocktail for 2-3 hours at room temperature to cleave the peptidomimetic from the resin and remove side-chain protecting groups.
 - Filter to separate the resin and collect the filtrate containing the crude product.
- Purification and Characterization:
 - Precipitate the crude peptidomimetic from the TFA solution by adding cold diethyl ether.
 - Centrifuge to pellet the product, decant the ether, and repeat the ether wash.
 - Dry the crude product under vacuum.
 - Dissolve the crude product in a minimal amount of a suitable solvent (e.g., water/acetonitrile mixture).
 - Purify the peptidomimetic using reverse-phase high-performance liquid chromatography (RP-HPLC).
 - Confirm the identity and purity of the final product by Mass Spectrometry (e.g., ESI-MS) and analytical HPLC.

C. Efficient Assembly: The Role of Click Chemistry

Expertise & Rationale: The Copper(I)-catalyzed Azide-Alkyne Cycloaddition (CuAAC), the most prominent example of "click chemistry," is a powerful tool for synthesizing complex molecules from simpler building blocks.^{[13][14]} Its high efficiency, mild reaction conditions, and biocompatibility make it ideal for drug discovery.^[13] In antimicrobial synthesis, click chemistry can be used to link different pharmacophores, conjugate molecules to targeting moieties, or rapidly generate libraries of compounds for screening.^{[14][15]} The resulting 1,2,3-triazole ring

is not just a passive linker; it is a stable, polar, and hydrogen-bond-accepting moiety that can favorably interact with biological targets.[14]

This diagram illustrates the fundamental transformation in a CuAAC reaction.

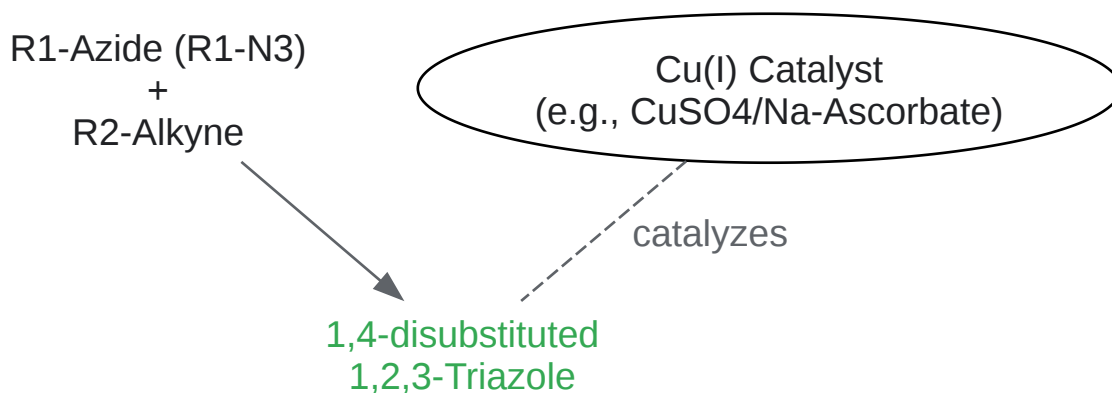

[Click to download full resolution via product page](#)

Caption: The Copper(I)-catalyzed Azide-Alkyne Cycloaddition (CuAAC) reaction.

This protocol describes a general method for coupling an azide-functionalized fragment with an alkyne-functionalized fragment.

- Reagents & Setup:
 - Azide-containing molecule (Fragment A, 1 equivalent)
 - Alkyne-containing molecule (Fragment B, 1 equivalent)
 - Copper(II) sulfate pentahydrate (CuSO₄·5H₂O) (0.05 - 0.1 equivalents)
 - Sodium ascorbate (0.1 - 0.2 equivalents)
 - Solvent system (e.g., a 1:1 mixture of t-butanol and water)
 - Schlenk flask or standard round-bottom flask.
- Procedure:

- Dissolve Fragment A (azide) and Fragment B (alkyne) in the t-butanol/water solvent system in the reaction flask.
- In a separate vial, prepare a fresh solution of sodium ascorbate in water.
- In another vial, prepare a solution of copper(II) sulfate in water.
- Add the sodium ascorbate solution to the main reaction mixture, followed by the copper(II) sulfate solution. The sodium ascorbate reduces Cu(II) to the active Cu(I) catalyst in situ.
- Stir the reaction vigorously at room temperature. The reaction is often complete within 1-24 hours. Monitor by TLC or LC-MS.
- Upon completion, dilute the reaction mixture with water and extract the product with an organic solvent like ethyl acetate (3 times).
- Combine the organic layers, wash with brine, dry over anhydrous sodium sulfate (Na_2SO_4), and concentrate under reduced pressure.
- Purification and Characterization:
 - Purify the crude product using flash column chromatography on silica gel.
 - Characterize the final triazole-linked compound by NMR (^1H and ^{13}C) and High-Resolution Mass Spectrometry (HRMS) to confirm its structure and purity.

Section 2: Protocol for Biological Validation

The synthesis of a novel compound is only the first step. A robust, reproducible method to assess its biological activity is paramount. The Minimum Inhibitory Concentration (MIC) assay is the gold standard for quantifying the in vitro efficacy of a potential antimicrobial agent.^[16]

Protocol: Broth Microdilution for MIC Determination

Rationale: This method determines the lowest concentration of an antimicrobial agent that prevents the visible growth of a microorganism. It is a quantitative, scalable, and standardized method recommended by bodies like the Clinical and Laboratory Standards Institute (CLSI) and the European Committee on Antimicrobial Susceptibility Testing (EUCAST).^{[17][18]}

- Preparation of Materials:
 - Bacterial Inoculum: From a fresh agar plate, pick several well-isolated colonies of the test bacterium (e.g., *S. aureus* ATCC 29213). Suspend them in sterile saline or broth to match the turbidity of a 0.5 McFarland standard (approximately 1.5×10^8 CFU/mL).[16] Dilute this suspension to achieve a final concentration of approximately 5×10^5 CFU/mL in the test wells.[19]
 - Antimicrobial Stock Solution: Prepare a concentrated stock solution of the synthesized compound in a suitable solvent (e.g., DMSO).
 - Growth Medium: Use cation-adjusted Mueller-Hinton Broth (MHB) for most non-fastidious bacteria.[19]
 - 96-Well Microtiter Plate: Use sterile, U-bottom or flat-bottom plates.
- Assay Setup (Serial Dilution):
 - Add 50 μ L of sterile MHB to wells 2 through 12 of a microtiter plate row.
 - Prepare a 2x working solution of your compound. Add 100 μ L of this solution to well 1.
 - Perform a 2-fold serial dilution by transferring 50 μ L from well 1 to well 2. Mix well by pipetting up and down.
 - Continue this serial transfer from well 2 to well 3, and so on, up to well 10. Discard the final 50 μ L from well 10.
 - Well 11 will serve as the growth control (no drug). Add no compound to it.
 - Well 12 will serve as the sterility control (no bacteria). Add no compound or bacteria to it.
- Inoculation and Incubation:
 - Add 50 μ L of the prepared bacterial inoculum (at $\sim 1 \times 10^6$ CFU/mL) to wells 1 through 11. This dilutes the drug and bacteria to their final 1x concentrations. The final volume in each well will be 100 μ L.

- Cover the plate and incubate at 35-37°C for 16-20 hours in ambient air.
- Reading and Interpreting Results:
 - After incubation, examine the plate visually (or with a plate reader) for turbidity.
 - The MIC is the lowest concentration of the antimicrobial agent (the first well from the left) that shows no visible growth (i.e., is clear).
 - The growth control (well 11) should be turbid, and the sterility control (well 12) should be clear.

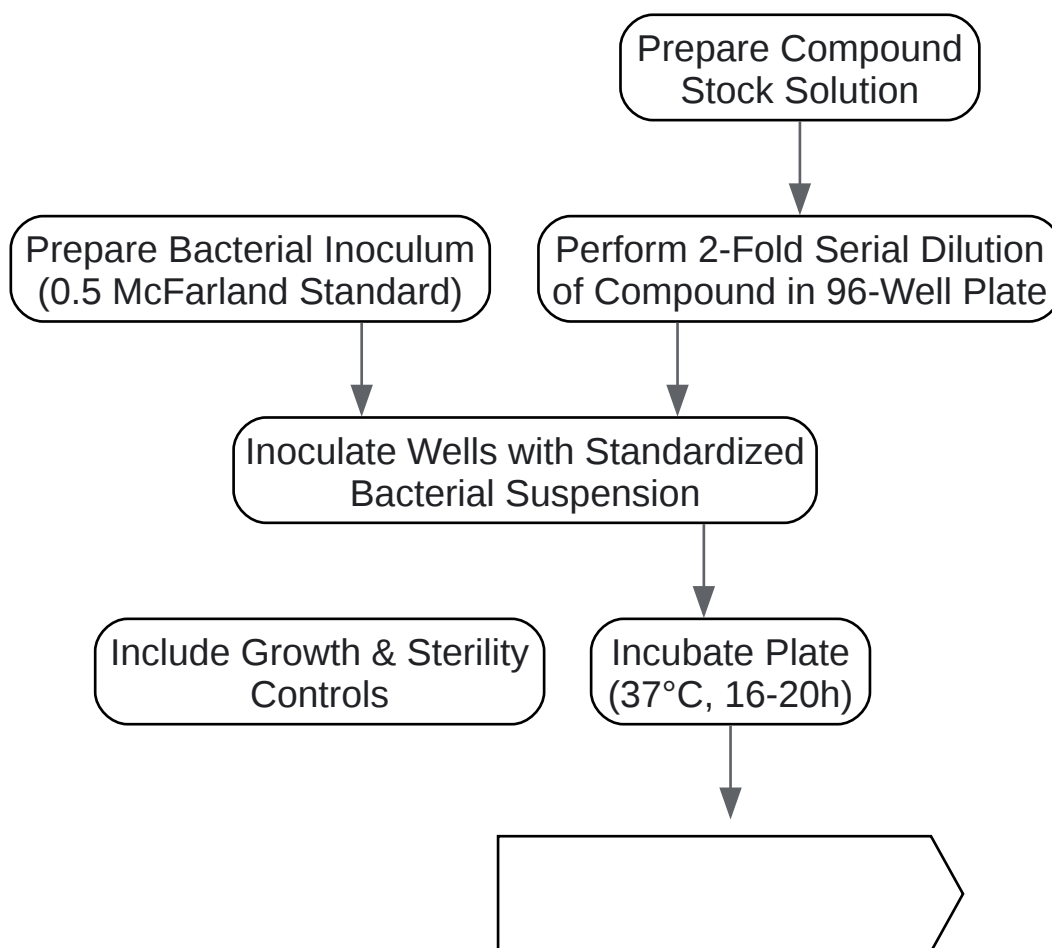

[Click to download full resolution via product page](#)

Caption: Experimental workflow for determining Minimum Inhibitory Concentration (MIC).

Data Presentation

Summarize the quantitative results from the MIC assays in a clear, structured table.

Compound ID	Target Organism	MIC ($\mu\text{g/mL}$)
QSI-Bn-01	<i>P. aeruginosa</i> PAO1	64
QSI-Bn-01	<i>S. aureus</i> ATCC 29213	>128
PepM-05	<i>P. aeruginosa</i> PAO1	32
PepM-05	<i>S. aureus</i> ATCC 29213	8
PepM-05	<i>E. coli</i> ATCC 25922	16
Click-AB-03	<i>S. aureus</i> ATCC 29213	16
Vancomycin	<i>S. aureus</i> ATCC 29213	1

Table 1: Example MIC data for newly synthesized compounds against common bacterial strains. Vancomycin is included as a positive control.

References

- Al-Hourani, B. J., Al-Trawneh, S. A., Al-Dmour, R. S., W अल-Hourani, B., Al-Trawneh, S., Al-Dmour, R., Wessjohann, L., & Al-Aboudi, A. (2023). Design and Synthesis of Novel Antimicrobial Agents. *Antibiotics*, 12(4), 654. [[Link](#)]
- MDPI. (n.d.). Special Issue: Design and Synthesis of Antimicrobial Compounds. MDPI.com. [[Link](#)]
- Méndez-Samperio, P. (2014). Peptidomimetics as a new generation of antimicrobial agents: current progress. *Infection and Drug Resistance*, 7, 195–205. [[Link](#)]
- Theuretzbacher, U., Piddock, L. J. V., & Berman, J. (2021). Challenges and shortcomings of antibacterial discovery projects. *JAC-Antimicrobial Resistance*, 3(3), dlab130. [[Link](#)]
- Zhou, Y., & Lu, J. (2015). The application of click chemistry in the synthesis of agents with anticancer activity. *International Journal of Molecular Sciences*, 16(3), 6357–6377. [[Link](#)]

- Jain, A., & Agarwal, A. (2023). Antimicrobial Susceptibility Testing. In StatPearls. StatPearls Publishing. [\[Link\]](#)
- Dalvie, D. K., Kalgutkar, A. S., & Smith, D. A. (2024). Synthetic Approaches to the New Drugs Approved during 2023. *Journal of Medicinal Chemistry*. [\[Link\]](#)
- Fleeman, R. M., LaBreck, P. T., & D'Orazio, S. E. F. (2022). Elucidating the Mechanisms of Action of Antimicrobial Agents. *Microbiology Spectrum*, 10(2), e02324-21. [\[Link\]](#)
- Al-Hourani, B. J., Al-Trawneh, S. A., Al-Dmour, R. S., Wessjohann, L., & Al-Aboudi, A. (2023). Design and Synthesis of Novel Antimicrobial Agents. *Antibiotics*, 12(4), 654. [\[Link\]](#)
- Wang, J., Dou, X., Song, J., Lyu, Y., Zhu, X., Xu, L., Li, W., & Shan, A. (2021). The Total Chemical Synthesis and Biological Evaluation of the Cationic Antimicrobial Peptides, Laterocidine and Brevicidine. *Journal of Natural Products*, 84(9), 2446–2454. [\[Link\]](#)
- El-Sayed, N. F., El-Sattar, N. E. A., & El-Gazzar, M. G. (2023). Design, Synthesis, and Biological Evaluation of the Quorum-Sensing Inhibitors of *Pseudomonas aeruginosa* PAO1. *ACS Omega*, 8(3), 3290–3304. [\[Link\]](#)
- Perry, J. A., & Wright, G. D. (2024). Challenges and Opportunities with Antibiotic Discovery and Exploratory Research. *ACS Infectious Diseases*. [\[Link\]](#)
- Salama, A. H. (2020). ANTIMICROBIAL PEPTIDES SYNTHESIS AND MECHANISM OF ACTION. *PharmacologyOnLine*, 3, 1404-1410. [\[Link\]](#)
- Al-Hourani, B. J., Al-Trawneh, S. A., Al-Dmour, R. S., Wessjohann, L., & Al-Aboudi, A. (2023). Design and Synthesis of Novel Antimicrobial Agents. *Antibiotics*, 12(4), 654. [\[Link\]](#)
- Kumar, S., De Vita, D., Mthombeni, N., Abrahams, G., Van Zyl, R. L., & Laming, D. (2023). Synthesis of Novel Quinazolinone Analogues for Quorum Sensing Inhibition. *Molecules*, 28(14), 5368. [\[Link\]](#)
- Arslan, M., & Temel, S. (2018). Contribution of “click chemistry” to the synthesis of antimicrobial aliphatic copolyester. *ResearchGate*. [\[Link\]](#)

- Dalvie, D. K., Kalgutkar, A. S., & Smith, D. A. (2024). Synthetic Approaches to the New Drugs Approved during 2023. *Journal of Medicinal Chemistry*. [\[Link\]](#)
- OIE. (2014). METHODOLOGIES FOR ANTIMICROBIAL SUSCEPTIBILITY TESTING. OIE. [\[Link\]](#)
- Aslam, B., Wang, W., Arshad, M. I., Khurshid, M., Muzammil, S., Rasool, M. H., Nisar, M. A., Alvi, R. F., Aslam, M. A., Qamar, M. U., Salamat, M. K. F., & Baloch, Z. (2018). Antibiotic resistance: a rundown of a global crisis. *Infection and Drug Resistance*, 11, 1645–1658. [\[Link\]](#)
- Sycheva, M. V., Panteleev, P. V., Ovchinnikova, T. V., & Shenkarev, Z. O. (2023). Creation of New Antimicrobial Peptides. *Molecules*, 28(11), 4443. [\[Link\]](#)
- Storz, M. P., Brengel, C., Weidel, E., Hoffmann, M., Hollemeyer, K., Empting, M., Hartmann, R. W., & Müller, R. (2014). Novel approaches for the design and discovery of quorum-sensing inhibitors. *Future Medicinal Chemistry*, 6(12), 1363–1381. [\[Link\]](#)
- Depoorter, E., & Willand, N. (2023). Antibiotics with novel mode of action as new weapons to fight antimicrobial resistance. *European Journal of Medicinal Chemistry*, 256, 115413. [\[Link\]](#)
- Creative Biolabs. (n.d.). Mode of Action & Target for Antibacterial Drug. Creative Biolabs. [\[Link\]](#)
- Choudhary, M., Sharma, A. K., & Kumar, H. (2023). Synthetic Biology's Latest Trends in Antimicrobial Resistance and Biofilm. *International Journal of Microbiology*. [\[Link\]](#)
- Singh, A., Kumar, A., & Singh, R. K. (2023). Mitigating Antimicrobial Resistance through Strategic Design of Multimodal Antibacterial Agents Based on 1,2,3-Triazole with Click Chemistry. *ACS Bio & Med Chem Au*. [\[Link\]](#)
- WOA. (n.d.). LABORATORY METHODOLOGIES FOR BACTERIAL ANTIMICROBIAL SUSCEPTIBILITY TESTING. WOA. [\[Link\]](#)
- Heredero-Bermejo, I., Copa-Patiño, J. L., Soliveri, J., Fuentes-Paniagua, E., de la Mata, F. J., Gómez, R., & Muñoz-Fernández, M. Á. (2022). Synthesis and mechanism-of-action of a

novel synthetic antibiotic based on a dendritic system with bow-tie topology. *Frontiers in Microbiology*, 13, 959392. [[Link](#)]

- Al-Tawfiq, J. A., & Momattin, H. (2021). Recent advances and challenges in antibacterial drug development. *Expert Review of Anti-infective Therapy*, 19(11), 1399–1411. [[Link](#)]
- He, H., Wang, Y., & Liu, L. (2024). Recent Advances in Amphipathic Peptidomimetics as Antimicrobial Agents to Combat Drug Resistance. *Molecules*, 29(11), 2492. [[Link](#)]
- Han, M., Wang, Y., Zhang, S., Li, Z., Xu, J., Wang, Y., Li, Y., & Wang, R. (2021). Antimicrobial Peptides: Classification, Design, Application and Research Progress in Multiple Fields. *Frontiers in Microbiology*, 12, 690292. [[Link](#)]
- D'hooghe, M., & De Kimpe, N. (2011). Novel and Recent Synthesis and Applications of β -Lactams. In *Beta-Lactams: Novel Synthetic Pathways and Applications*. [[Link](#)]
- Chin, J., & Muchtar, F. (2020). Mechanisms of Action by Antimicrobial Agents: A Review. *McGill Journal of Medicine*, 18(1), 3. [[Link](#)]
- Jakobsen, T. H., van Gennip, M., Phipps, R. K., Shanmugham, M. S., Christensen, L. D., Alhede, M., Skindersoe, M. E., Rasmussen, T. B., Friedrich, K., Schulz, S., Daniels, C., Melchior, M., Nielsen, T. E., Givskov, M., & Tolker-Nielsen, T. (2013). Itaconimides as Novel Quorum Sensing Inhibitors of *Pseudomonas aeruginosa*. *Frontiers in Cellular and Infection Microbiology*, 3, 57. [[Link](#)]
- Zhang, R. (2023). Covalent Inhibitors Targeting FabH: A Cutting-edge Strategy in the Development of Novel Antibiotics. *Transactions on Materials, Biotechnology and Life Sciences*, 1(1). [[Link](#)]
- Blaskovich, M. (2022). Improving our ability to discover new antibiotics – a chemist's overview. *Biochemical Society*. [[Link](#)]
- Sharma, A. (2023). Challenges and Innovations in the Development of Antimicrobial Reagents. *LinkedIn*. [[Link](#)]
- Wood, C. (2023). Metal compounds identified as potential new antibiotics, thanks to robots doing 'click chemistry'. *Live Science*. [[Link](#)]

- Al-Zahrani, A. A., Al-Ghamdi, M. A., Al-Amer, O. M., Al-Otaibi, T. M., Al-Dossary, A. M., Al-Subaie, A. M., Al-Ghamdi, S. A., & Al-Otaibi, A. M. (2023). Quorum Sensing Inhibitors: An Alternative Strategy to Win the Battle against Multidrug-Resistant (MDR) Bacteria. *Molecules*, 28(19), 6939. [[Link](#)]
- EUCAST. (n.d.). EUCAST Home. eucast.org. [[Link](#)]
- Sklyar, N., & Zotchev, S. B. (2021). Modern Trends in Natural Antibiotic Discovery. *Antibiotics*, 10(11), 1292. [[Link](#)]
- Yesbolatova, A., & Yespembetov, B. (2021). The Main Directions of Antimicrobial Peptides Use and Synthesis Overview. *Advances in Bioscience and Biotechnology*, 12(11), 385-407. [[Link](#)]
- Baron, S. (Ed.). (1996). *Medical Microbiology* (4th ed.). University of Texas Medical Branch at Galveston. [[Link](#)]
- Silver, L. L. (2020). Antibacterial Discovery: 21st Century Challenges. *Antibiotics*, 9(5), 220. [[Link](#)]
- Nocentini, A., & Supuran, C. T. (2019). Click Chemistry-Enabled Parallel Synthesis of N-Acyl Sulfonamides and Their Evaluation as Carbonic Anhydrase Inhibitors. *Molecules*, 24(16), 2955. [[Link](#)]
- Al-Hourani, B. J., Al-Trawneh, S. A., Al-Dmour, R. S., Wessjohann, L., & Al-Aboudi, A. (2023). Design and Synthesis of Novel Antimicrobial Agents. *ResearchGate*. [[Link](#)]
- Méndez-Samperio, P. (2014). Peptidomimetics as a new generation of antimicrobial agents: current progress. *Infection and Drug Resistance*, 7, 195–205. [[Link](#)]
- Dalvie, D. K., Kalgutkar, A. S., & Smith, D. A. (2024). Synthetic Approaches to the New Drugs Approved during 2023. *Journal of Medicinal Chemistry*. [[Link](#)]
- FDA. (2023). Antibacterial Susceptibility Test Interpretive Criteria. FDA.gov. [[Link](#)]

Need Custom Synthesis?

BenchChem offers custom synthesis for rare earth carbides and specific isotopic labeling.

Email: info@benchchem.com or [Request Quote Online](#).

Sources

- [1. pubs.acs.org](https://pubs.acs.org) [pubs.acs.org]
- [2. hilarispublisher.com](https://hilarispublisher.com) [hilarispublisher.com]
- [3. pubs.acs.org](https://pubs.acs.org) [pubs.acs.org]
- [4. Synthetic Approaches to the New Drugs Approved during 2023 - PubMed](#) [pubmed.ncbi.nlm.nih.gov]
- [5. Frontiers | Itaconimides as Novel Quorum Sensing Inhibitors of Pseudomonas aeruginosa](#) [frontiersin.org]
- [6. Antibiotics with novel mode of action as new weapons to fight antimicrobial resistance - PubMed](#) [pubmed.ncbi.nlm.nih.gov]
- [7. mdpi.com](https://mdpi.com) [mdpi.com]
- [8. Quorum Sensing Inhibitors: An Alternative Strategy to Win the Battle against Multidrug-Resistant \(MDR\) Bacteria - PMC](#) [pmc.ncbi.nlm.nih.gov]
- [9. researchgate.net](https://researchgate.net) [researchgate.net]
- [10. The Main Directions of Antimicrobial Peptides Use and Synthesis Overview](#) [scirp.org]
- [11. researchgate.net](https://researchgate.net) [researchgate.net]
- [12. dovepress.com](https://dovepress.com) [dovepress.com]
- [13. The application of click chemistry in the synthesis of agents with anticancer activity - PMC](#) [pmc.ncbi.nlm.nih.gov]
- [14. pubs.acs.org](https://pubs.acs.org) [pubs.acs.org]
- [15. livescience.com](https://livescience.com) [livescience.com]
- [16. Antimicrobial Susceptibility Testing - StatPearls - NCBI Bookshelf](#) [ncbi.nlm.nih.gov]
- [17. EUCAST: EUCAST - Home](https://eucast.org) [eucast.org]
- [18. fda.gov](https://fda.gov) [fda.gov]
- [19. pdb.apec.org](https://pdb.apec.org) [pdb.apec.org]

- To cite this document: BenchChem. [Application Notes & Protocols: Strategic Synthesis of Novel Antimicrobial Agents]. BenchChem, [2026]. [Online PDF]. Available at: [<https://www.benchchem.com/product/b176724/docs#application-notes-protocols-strategic-synthesis-of-novel-antimicrobial-agents>]

Disclaimer & Data Validity:

The information provided in this document is for Research Use Only (RUO) and is strictly not intended for diagnostic or therapeutic procedures. While BenchChem strives to provide accurate protocols, we make no warranties, express or implied, regarding the fitness of this product for every specific experimental setup.

Technical Support: The protocols provided are for reference purposes. Unsure if this reagent suits your experiment?

Need Industrial/Bulk Grade? [Request Custom Synthesis Quote](#)

BenchChem

Our mission is to be the trusted global source of essential and advanced chemicals, empowering scientists and researchers to drive progress in science and industry.

Contact

Address: 3281 E Guasti Rd
Ontario, CA 91761, United States
Phone: (601) 213-4426
Email: info@benchchem.com

[Contact our Ph.D. Support Team for a compatibility check](#)