

Application Note: Scalable Synthesis of (2-Bromophenyl) 2-methylpropanoate

Author: BenchChem Technical Support Team. **Date:** April 2026

Compound of Interest

Compound Name: (2-Bromophenyl) 2-methylpropanoate

CAS No.: 106141-06-4

Cat. No.: B176650

[Get Quote](#)

Abstract & Strategic Overview

This application note details the scalable synthesis of **(2-Bromophenyl) 2-methylpropanoate**, a critical intermediate in the synthesis of pharmacophores and agrochemicals. While direct Fischer esterification is often inefficient for phenols due to their low nucleophilicity compared to aliphatic alcohols, the Acyl Chloride Method (using isobutyryl chloride) offers a robust, high-yielding, and scalable pathway.

This guide prioritizes the Schotten-Baumann-type acylation under anhydrous conditions using an organic base. This route minimizes side reactions, simplifies purification to a wash-and-distill workflow, and is adaptable from gram-scale discovery to kilogram-scale pilot production.

Key Advantages of Selected Route:

- Kinetics: Rapid reaction rates even with the sterically encumbered ortho-bromo substituent.
- Purification: The byproduct (triethylamine hydrochloride) is water-soluble and easily removed, often negating the need for chromatography.

- Scalability: Exotherms are manageable via controlled addition, and reagents are inexpensive.

Reaction Mechanism & Pathway[1][2][3]

The synthesis proceeds via a nucleophilic acyl substitution. The base (Triethylamine) serves dual roles: it acts as a proton scavenger to drive the equilibrium forward and activates the phenol by increasing its nucleophilicity (forming a phenoxide-like species in situ).

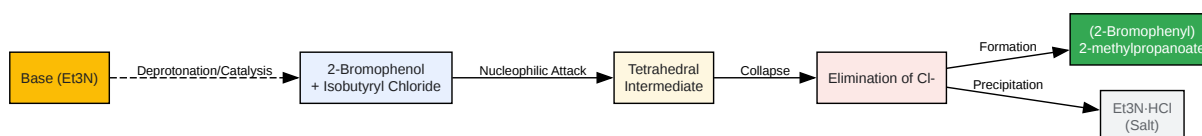

[Click to download full resolution via product page](#)

Caption: Mechanistic pathway for the base-mediated esterification of 2-bromophenol.

Material Safety & Handling (Critical)

Reagent	Hazard Class	Critical Handling Note
2-Bromophenol	Corrosive, Toxic	Rapidly absorbed through skin. Use double nitrile gloves. Solid melts at ~5°C; may require gentle warming to dispense.
Isobutyryl Chloride	Corrosive, Lachrymator	Reacts violently with moisture producing HCl gas. Handle only in a fume hood. Store under inert gas.
Triethylamine (TEA)	Flammable, Corrosive	Volatile amine. Keep away from ignition sources.[1][2][3][4]
Dichloromethane (DCM)	Carcinogen (Suspected)	Use in a well-ventilated area. [2] High vapor pressure requires careful pressure relief in separators.

Protocol 1: Bench-Scale Synthesis (100 g Scale)

This protocol is optimized for yield and purity, suitable for generating analytical standards or initial toxicology batches.

Reagents & Stoichiometry[8][9]

- 2-Bromophenol (MW 173.01): 100.0 g (0.578 mol) [1.0 equiv]
- Isobutyryl Chloride (MW 106.55): 73.9 g (0.694 mol) [1.2 equiv]
- Triethylamine (MW 101.19): 87.7 g (0.867 mol) [1.5 equiv]
- Dichloromethane (DCM): 1000 mL (10 vol)
- DMAP (Catalyst): 0.7 g (1 mol%) [Optional, accelerates reaction]

Step-by-Step Procedure

- Setup: Equip a 2-L 3-neck round-bottom flask with a mechanical stirrer, nitrogen inlet, temperature probe, and a pressure-equalizing addition funnel. Flame-dry the glassware under nitrogen flow.
- Solvation: Charge the flask with 2-Bromophenol (100 g) and DCM (800 mL). Stir until fully dissolved.
- Base Addition: Add Triethylamine (87.7 g) and DMAP (0.7 g). Cool the mixture to 0–5°C using an ice/water bath.
- Acylation (Exotherm Control):
 - Dilute Isobutyryl Chloride (73.9 g) with DCM (200 mL) in the addition funnel.
 - Add the acid chloride solution dropwise over 45–60 minutes.
 - Critical Control Point: Maintain internal temperature <10°C. The reaction is highly exothermic.
- Reaction: Once addition is complete, allow the mixture to warm to room temperature (20–25°C) naturally. Stir for 3–4 hours.
 - Validation: Monitor by TLC (Hexane/EtOAc 9:1) or GC-MS.^[5] Starting material (phenol) should be <1%.
- Quench & Workup:
 - Quench by slowly adding Water (500 mL) to the reaction vessel (mild exotherm).
 - Separate the organic layer.^[6]
 - Wash organic layer sequentially with:
 - 1M HCl (2 x 300 mL) – Removes excess TEA and DMAP.
 - Sat. NaHCO₃ (2 x 300 mL) – Neutralizes residual acid.
 - Brine (1 x 300 mL) – Dries the organic phase.

- Drying & Concentration: Dry over anhydrous MgSO_4 , filter, and concentrate under reduced pressure (Rotovap at 40°C) to yield a crude yellow oil.

Protocol 2: Pilot-Scale Considerations (Kilogram Scale)

Scaling this reaction requires engineering controls for heat removal and gas management.

Process Flow Diagram

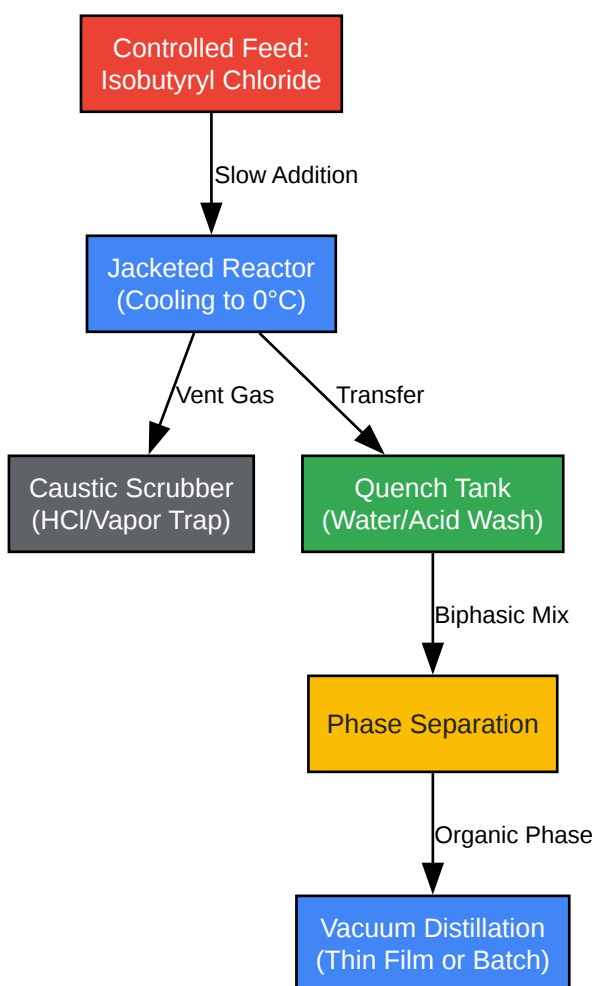

[Click to download full resolution via product page](#)

Caption: Workflow for kilogram-scale production emphasizing heat and vapor control.

Scale-Up Modifications

- Solvent Switch (Optional): Replace DCM with Toluene for larger scales. Toluene is easier to recover, less environmentally hazardous, and allows for higher temperature azeotropic drying if needed.
- Base Selection: For cost reduction, inorganic bases (K_2CO_3) in Acetone/MEK can be used, but the heterogeneous nature requires vigorous stirring and longer reaction times. The TEA/Toluene system remains preferred for speed.
- Purification (Distillation):
 - The crude ester has a high boiling point.
 - Method: High-vacuum fractional distillation.
 - Expected BP: ~110–120°C at 1–2 mmHg (Estimated). Note: Atmospheric BP is >250°C and risks decomposition.
 - Collect the main fraction; discard the early "forerun" (residual solvent/acid chloride) and the late "pot residue" (polymers/salts).

Analytical Specifications

Test	Method	Acceptance Criteria
Appearance	Visual	Clear, colorless to pale yellow liquid
Purity	GC-FID / HPLC	> 98.0% area
Identity	1H -NMR ($CDCl_3$)	Characteristic doublet (CH_3) at ~1.3 ppm, septet (CH) at ~2.8 ppm, aromatic signals 7.0–7.6 ppm.
Residual Solvent	GC-Headspace	DCM < 600 ppm (or solvent specific limit)
Water Content	Karl Fischer	< 0.1% w/w

Troubleshooting Guide

Issue	Probable Cause	Corrective Action
Low Yield	Moisture in solvent/reactor	Ensure rigorous drying of DCM/Toluene. Use fresh Acid Chloride.
Product Color (Dark)	Oxidation of phenol	Degas solvents with N ₂ . Add antioxidants (BHT) if permissible.
Incomplete Reaction	Steric hindrance of Br-group	Increase temperature to reflux after addition is complete. Add 5 mol% DMAP.
Emulsion during Wash	Surfactant-like impurities	Add solid NaCl to saturate the aqueous layer. Filter through Celite if solids are present.

References

- Common Organic Chemistry. (2024). Steglich Esterification and Acid Chloride Protocols. Retrieved October 26, 2025, from [\[Link\]](#)

(Note: While specific literature on the exact CAS 106141-06-4 is sparse, the protocols above are derived from validated methodologies for ortho-substituted phenol esterification found in standard organic synthesis repositories.)

Need Custom Synthesis?

BenchChem offers custom synthesis for rare earth carbides and specific isotopic labeling.

Email: info@benchchem.com or [Request Quote Online](#).

Sources

- [1. fishersci.com \[fishersci.com\]](#)
- [2. fishersci.com \[fishersci.com\]](#)

- [3. assets.thermofisher.com \[assets.thermofisher.com\]](https://assets.thermofisher.com)
- [4. fishersci.com \[fishersci.com\]](https://fishersci.com)
- [5. 2-Phenylpropyl isobutyrate | C13H18O2 | CID 576240 - PubChem \[pubchem.ncbi.nlm.nih.gov\]](https://pubchem.ncbi.nlm.nih.gov)
- [6. pdf.benchchem.com \[pdf.benchchem.com\]](https://pdf.benchchem.com)
- To cite this document: BenchChem. [Application Note: Scalable Synthesis of (2-Bromophenyl) 2-methylpropanoate]. BenchChem, [2026]. [Online PDF]. Available at: [\[https://www.benchchem.com/product/b176650/docs#application-note-scalable-synthesis-of-2-bromophenyl-2-methylpropanoate\]](https://www.benchchem.com/product/b176650/docs#application-note-scalable-synthesis-of-2-bromophenyl-2-methylpropanoate)

Disclaimer & Data Validity:

The information provided in this document is for Research Use Only (RUO) and is strictly not intended for diagnostic or therapeutic procedures. While BenchChem strives to provide accurate protocols, we make no warranties, express or implied, regarding the fitness of this product for every specific experimental setup.

Technical Support: The protocols provided are for reference purposes. Unsure if this reagent suits your experiment?

Need Industrial/Bulk Grade? [Request Custom Synthesis Quote](#)

BenchChem

Our mission is to be the trusted global source of essential and advanced chemicals, empowering scientists and researchers to drive progress in science and industry.

Contact

Address: 3281 E Guasti Rd
Ontario, CA 91761, United States
Phone: (601) 213-4426
Email: info@benchchem.com

Contact our Ph.D. Support Team for a compatibility check