

Application Note: Precision Synthesis of 2-Carbamoylnicotinic Acids

Author: BenchChem Technical Support Team. **Date:** May 2026

Compound of Interest

Compound Name: 2-(benzylcarbamoyl)pyridine-3-carboxylic Acid

CAS No.: 100872-65-9

Cat. No.: B176764

[Get Quote](#)

Controlling Regioselectivity in Pyridine Systems via Kinetic vs. Thermodynamic Pathways

Executive Summary

2-Carbamoylnicotinic acids (2-carboxamido-3-pyridinecarboxylic acids) are critical scaffolds in the synthesis of imidazolinone herbicides (e.g., Imazapyr) and kinase inhibitors. The synthesis of these molecules presents a classic regioselectivity challenge: differentiating between the C2 and C3 carbonyl centers of the pyridine ring.

This guide details the regioselective synthesis of 2-carbamoylnicotinic acids via the nucleophilic opening of quinolinic anhydride. We provide a validated protocol favoring the kinetic product (2-carbamoyl isomer) over the thermodynamic isomer (3-carbamoyl), supported by mechanistic insights and analytical differentiation methods.

Theoretical Framework & Mechanism

The Regioselectivity Challenge

The starting material, Quinolinic Anhydride (pyridine-2,3-dicarboxylic anhydride), contains two electrophilic carbonyl centers.

- C2 Carbonyl: Alpha to the pyridine nitrogen.
- C3 Carbonyl: Beta to the pyridine nitrogen.

Mechanistic Driver: The electron-withdrawing inductive effect (-I) of the pyridine nitrogen makes the C2 carbonyl more electrophilic than the C3 carbonyl. Consequently, under kinetic control (low temperature, non-polar solvents), nucleophiles (amines) preferentially attack C2.

- Pathway A (Kinetic - Favored): Attack at C2

Amide formation at C2

Carboxylic acid at C3. Result: 2-Carbamoylnicotinic Acid.

- Pathway B (Thermodynamic): Attack at C3

Amide formation at C3

Carboxylic acid at C2. Result: 3-Carbamoylpicolinic Acid.

Reaction Pathway Diagram

The following diagram illustrates the bifurcation of the reaction pathway based on nucleophilic attack.

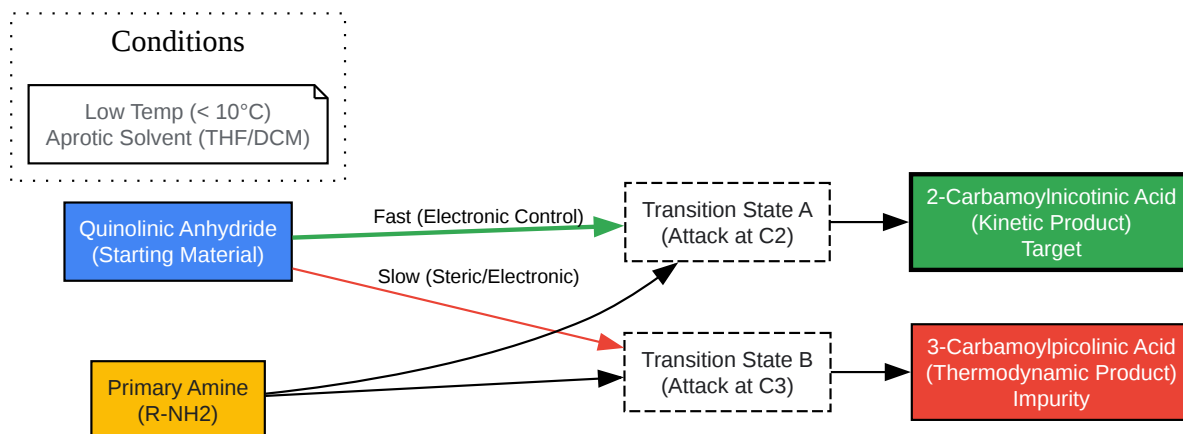

[Click to download full resolution via product page](#)

Figure 1: Mechanistic pathway for the ring-opening of quinolinic anhydride. Kinetic control favors the 2-carbamoyl isomer.

Experimental Protocol: Kinetic Synthesis

This protocol is optimized for the synthesis of 2-(isopropylcarbamoyl)nicotinic acid, a representative precursor.

Materials & Reagents

Reagent	Equiv.	Role	Critical Attribute
Quinolinic Anhydride	1.0	Substrate	Dry, free of diacid
Isopropylamine	1.1	Nucleophile	Dry, freshly distilled
THF (Tetrahydrofuran)	-	Solvent	Anhydrous, inhibitor-free
Dichloromethane (DCM)	-	Alt. Solvent	Anhydrous
Nitrogen (N ₂)	-	Atmosphere	Inert environment

Step-by-Step Methodology

Step 1: Preparation of Anhydride Solution

- Flame-dry a 250 mL three-neck round-bottom flask equipped with a magnetic stir bar, temperature probe, and N₂ inlet.
- Charge Quinolinic Anhydride (5.0 g, 33.5 mmol) into the flask.
- Add Anhydrous THF (50 mL) via cannula. Stir until fully dissolved.
 - Note: If the anhydride is not fully soluble, a small amount of DCM can be added, or the mixture can be gently warmed then cooled back down.
- Cool the solution to 0°C – 5°C using an ice/water bath.

Step 2: Controlled Addition of Amine (The Critical Step)

- Dissolve Isopropylamine (2.18 g, 36.9 mmol, 1.1 eq) in THF (10 mL) in a separate pressure-equalizing addition funnel.
- Add the amine solution dropwise over 30–45 minutes.
 - Control Point: Maintain internal temperature below 10°C. Rapid addition or exotherms can promote thermodynamic equilibration to the unwanted isomer.
- Once addition is complete, allow the reaction to stir at 0°C for 2 hours, then slowly warm to room temperature over 1 hour.

Step 3: Monitoring & Workup

- TLC Check: (Eluent: 10% MeOH in DCM with 1% Acetic Acid). The anhydride spot should disappear.
- Precipitation: In many cases, the product precipitates as a zwitterion or salt directly from THF.
 - If solid forms: Filter the solid under N₂. Wash with cold THF (2 x 10 mL).

- If solution remains clear: Concentrate the solvent to ~20% volume on a rotary evaporator, then add Diethyl Ether or Hexanes to induce precipitation.
- Acidification (Optional but recommended for free acid):
 - Dissolve the crude solid in minimal water (pH ~8-9).
 - Carefully acidify with 1M HCl to pH 3.0–3.5.
 - The free acid will precipitate. Filter, wash with cold water, and dry under vacuum at 40°C.

Purification Workflow Diagram

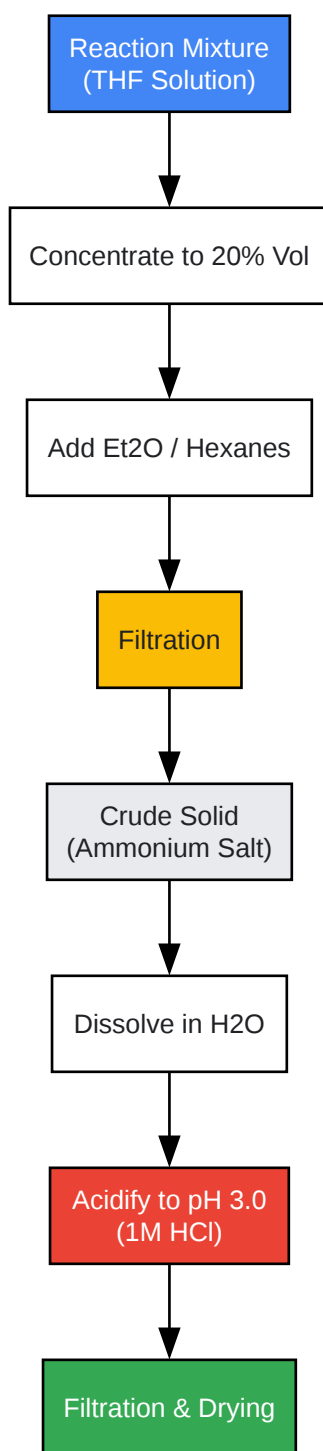

[Click to download full resolution via product page](#)

Figure 2: Isolation workflow for obtaining the free carboxylic acid.

Analytical Validation

Distinguishing the 2-carbamoyl isomer (Target) from the 3-carbamoyl isomer (Impurity) is best achieved via ^1H NMR.

NMR Diagnostic Signals (DMSO- d_6)

Feature	2-Carbamoyl (Target)	3-Carbamoyl (Impurity)	Mechanistic Reason
Amide NH	Typically 8.5 – 9.0 ppm (Broad doublet)	Often shifted downfield or distinct coupling	Different H-bonding environment.
H-4 Proton	~8.1 ppm (dd)	~7.8 ppm (dd)	H4 is beta to the carboxylic acid in the target, causing deshielding.
H-6 Proton	~8.7 ppm (dd)	~8.6 ppm (dd)	Proximity to ring nitrogen dominates, but subtle shifts occur due to C2 substituent.
^{13}C Carbonyl	Acid C=O: ~165 ppm Amide C=O: ~168 ppm	Acid C=O: ~163 ppm Amide C=O: ~166 ppm	Inductive effect of Nitrogen on C2-Carbonyl (Amide) vs C2-Carboxyl (Acid).

Note: Chemical shifts are approximate and solvent-dependent.

Troubleshooting & Optimization

Dealing with Isomer Mixtures

If the thermodynamic product (3-carbamoyl) is observed (>5%):

- **Temperature Control:** Ensure the reaction never exceeds 10°C during addition.
- **Solvent Switch:** Switch from THF to Dichloromethane (DCM) or Toluene. Non-polar solvents often enhance the kinetic selectivity by precipitating the product immediately, preventing equilibration.

- Recrystallization: The 2-carbamoylnicotinic acid is often less soluble in water at pH 3 than the 3-carbamoyl isomer. Recrystallization from Water/Ethanol (9:1) can enrich the target isomer.

"The Alpha Effect"

The high reactivity of the C2 carbonyl is due to the Alpha Effect—the adjacent nitrogen atom withdraws electron density, making the C2 carbon highly susceptible to nucleophilic attack. However, if the amine is extremely bulky (e.g., tert-butylamine), steric hindrance at C2 (flanked by N and C3-carbonyl) may force attack at C3. In such cases, using a stronger nucleophile or a catalyst (e.g., DMAP) is not recommended as it promotes equilibration.

References

- Title: Regioselective Synthesis of Imidazolinone Herbicides.
- Mechanistic Insights on Anhydride Reactions
 - Title: Nucleophilic Acyl Substitution of Anhydrides.[1]
 - Source: Chemistry LibreTexts.
 - URL:[[Link](#)]
- Analytical Characterization (NMR of Pyridines)
 - Title: Proton NMR Spectrum for Nicotinic Acid Deriv
 - Source: Stack Exchange / Hans Reich Collection.
 - URL:[[Link](#)]

Need Custom Synthesis?

BenchChem offers custom synthesis for rare earth carbides and specific isotopic labeling.

Email: info@benchchem.com or [Request Quote Online](#).

Sources

- [1. reactionweb.io](https://www.reactionweb.io) [[reactionweb.io](https://www.reactionweb.io)]

- To cite this document: BenchChem. [Application Note: Precision Synthesis of 2-Carbamoylnicotinic Acids]. BenchChem, [2026]. [Online PDF]. Available at: [<https://www.benchchem.com/product/b176764/docs#application-note-precision-synthesis-of-2-carbamoylnicotinic-acids>]

Disclaimer & Data Validity:

The information provided in this document is for Research Use Only (RUO) and is strictly not intended for diagnostic or therapeutic procedures. While BenchChem strives to provide accurate protocols, we make no warranties, express or implied, regarding the fitness of this product for every specific experimental setup.

Technical Support: The protocols provided are for reference purposes. Unsure if this reagent suits your experiment?

Need Industrial/Bulk Grade? [Request Custom Synthesis Quote](#)

BenchChem

Our mission is to be the trusted global source of essential and advanced chemicals, empowering scientists and researchers to drive progress in science and industry.

Contact

Address: 3281 E Guasti Rd
Ontario, CA 91761, United States
Phone: (601) 213-4426
Email: info@benchchem.com

[Contact our Ph.D. Support Team for a compatibility check](#)